

**TAJ Estates of Franklin II
230 East Central Street (Route 140)
Franklin, Massachusetts**

Transportation Impact Assessment Summary

Prepared by:



February 7, 2022

Transportation Impact Assessment Summary

- ▶ Prepared in accordance with MassDOT's *Transportation Impact Assessment (TIA) Guidelines* and includes a detailed assessment of traffic volumes, pedestrian and bicycle accommodations and public transportation services;
- ▶ Pre-COVID traffic volumes were used and adjusted to 2022 following MassDOT guidelines;
- ▶ The analysis concluded that the Project will not result in a significant impact (increase) on motorist delays or vehicle queuing over Existing or anticipated future conditions without the Project (No-Build conditions), with the majority of the movements shown to continue to operate at acceptable levels (LOS "D" or better);
- ▶ No apparent safety deficiencies were noted with respect to the motor vehicle crash history at the study area intersections; and
- ▶ Lines of sight at the Project site driveway intersection were found to exceed the recommended minimum distances for safe and efficient operation based on the appropriate approach speed.



Site Location Map

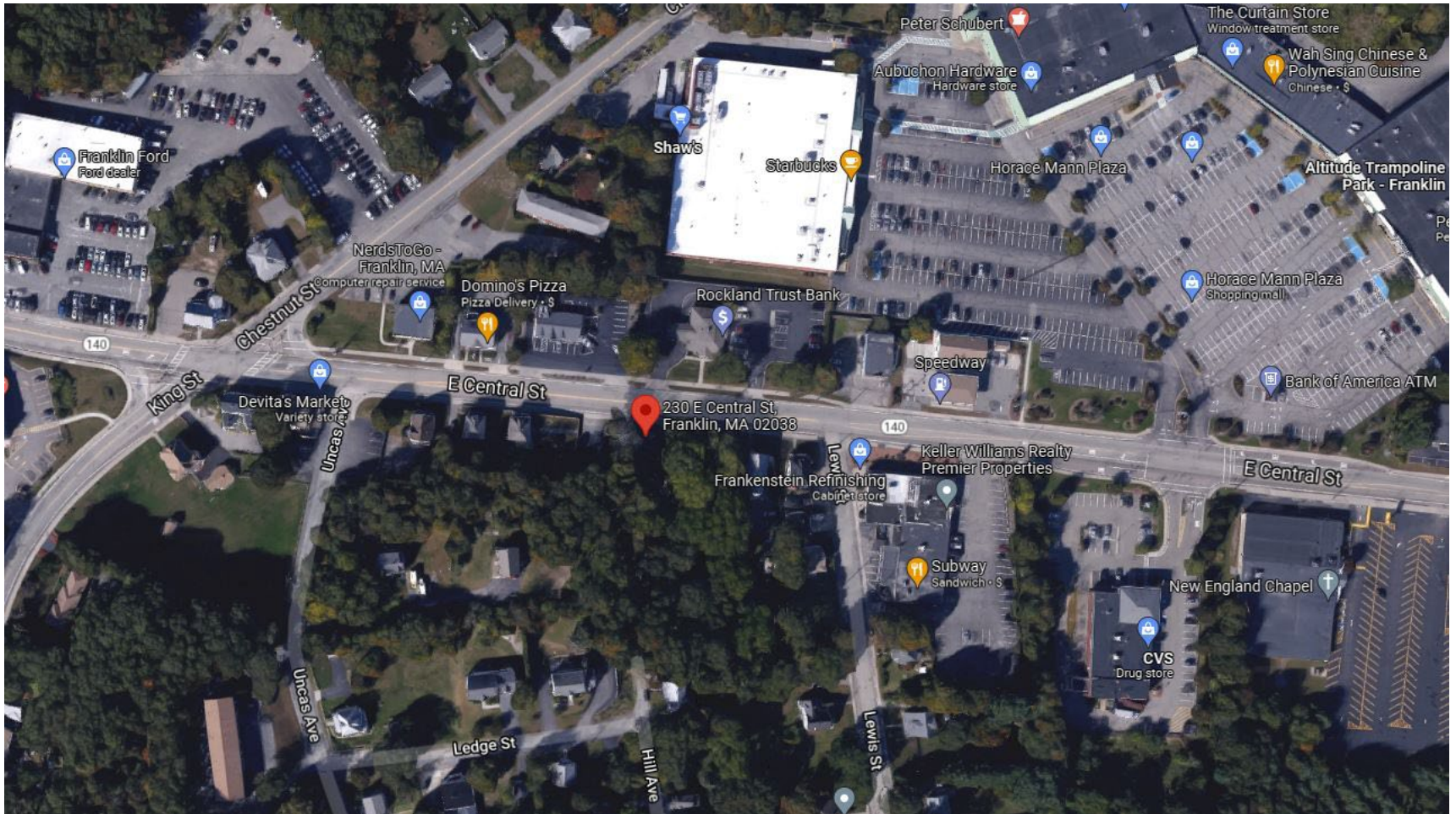

Trip Generation Summary

Time Period/Direction	Vehicle Trips		
	(A) Residential Component (35 units) ^a	(B) Office Component (900 sf) ^a	(A+B) Total
Average Weekday Daily:			
Entering	150	7	157
Exiting	<u>150</u>	<u>7</u>	<u>157</u>
Total	300	14	314
Weekday Morning Peak Hour:			
Entering	8	1	9
Exiting	<u>26</u>	<u>1</u>	<u>27</u>
Total	34	2	36
Weekday Evening Peak Hour:			
Entering	22	1	23
Exiting	<u>14</u>	<u>1</u>	<u>15</u>
Total	36	2	38

^aBased on ITE LUC 220, Multifamily Housing (Low-Rise).

^bBased on ITE LUC 712, Small Office Building..



Trip Distribution

Legend:

- XX** Entering Trips
- (XX)** Exiting Trips

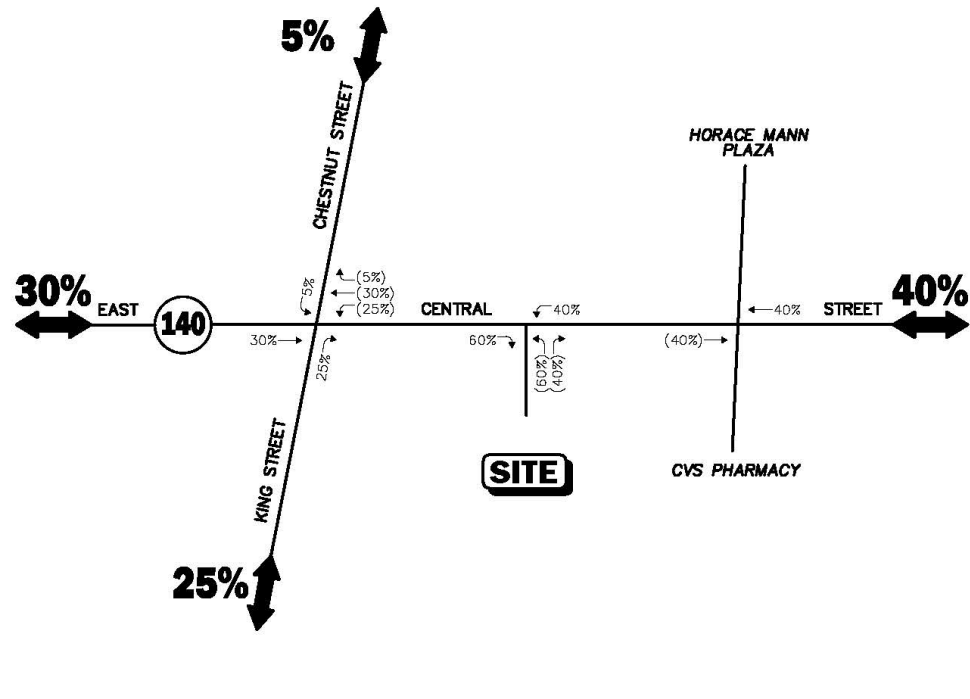

Recommendations

❖ Site Access

- ▶ The Project site driveway and internal circulating drives should be 24 feet in width and designed to accommodate the turning and maneuvering requirements of the largest anticipated responding emergency vehicle.
- ▶ Where perpendicular parking is proposed, the drive aisle behind the parking should be a minimum of 23 feet in order to facilitate parking maneuvers.
- ▶ Vehicles exiting the Project site should be placed under STOP-sign control with a marked STOP-line provided.
- ▶ All signs and pavement markings to be installed within the Project site should conform to the applicable standards of the Manual on Uniform Traffic Control Devices (MUTCD).
- ▶ Signs, landscaping and snow accumulations within intersection sight triangle areas should be designed and maintained so as not to restrict lines of sight.

❖ Off-Site

- ▶ ***Route 140 at King Street and Chestnut Street*** - An optimal traffic signal timing plan should be considered for advancement independent of the Project



Transportation Demand Management Program

- ▶ A transportation coordinator, who may also have other operations/management responsibilities, will be assigned for the Project to coordinate the TDM program;
- ▶ Information regarding public transportation services, maps, schedules, and fare information will be posted in a central location and/or otherwise made available to residents and employees;
- ▶ A “welcome packet” will be provided to residents and employees detailing available public transportation services, bicycle and walking alternatives, and commuter options;
- ▶ Pedestrian accommodations will be incorporated into the Project and consist of sidewalks and ADA-compliant wheelchair ramps at all pedestrian crossings where a sidewalk is present;
- ▶ An internal mailroom will be provided; and
- ▶ Secure bicycle parking will be provided within the Project site consisting of: i) exterior bicycle parking conveniently located proximate to building entrance; and ii) weather protected bicycle parking located in a secure area within the building.



MEMORANDUM

TO: Taj Estates II of Franklin, LLC
c/o Mr. Mirajuddin Ahmed
95 East Main Street
Westborough, MA 01581

FROM: Mr. Jeffrey S. Dirk, P.E., PTOE, FITE
Managing Partner
Vanasse & Associates, Inc.
35 New England Business Center Drive
Suite 140
Andover, MA 01810-1066
(978) 269-6830
jdirk@rdva.com



Professional Engineer in CT, MA, ME, NH, RI and VA

DATE: January 19, 2022

RE: 9217

SUBJECT: Transportation Impact Assessment
TAJ Estates of Franklin II – 230 East Central Street (Route 140)
Franklin, Massachusetts

Vanasse & Associates, Inc. (VAI) has conducted a Transportation Impact Assessment (TIA) in order to determine the potential impacts on the transportation infrastructure associated with the proposed construction of the TAJ Estates of Franklin II mixed-use development to be located at 230 East Central Street (Route 140) in Franklin, Massachusetts (hereafter referred to as the “Project”). This study evaluates the following specific areas as they relate to the Project: i) access requirements; ii) potential off-site improvements; and iii) safety considerations; and identifies and analyzes existing traffic conditions and future traffic conditions, both with and without the Project along Route 140 and at the intersections of Route 140 at King Street and Chestnut Street, and Route 140 at the CVS/Pharmacy and Horace Mann Plaza Driveways. Based on this assessment, we have concluded the following with respect to the Project:

1. Using trip-generation statistics published by the Institute of Transportation Engineers (ITE)¹ for similar land uses as those proposed, the Project is expected to generate approximately 314 vehicle trips on an average weekday (two-way, 24-hour volume), with 36 vehicle trips expected during the weekday morning peak-hour and 38 vehicle trips expected during the weekday evening peak-hour;
2. The Project will not result in a significant impact (increase) on motorist delays or vehicle queuing over anticipated future conditions without the Project (No-Build condition), with the majority of the movements at the study intersections shown to continue to operate at a level-of-service (LOS) of D or better, where an LOS of “D” or better is defined as “acceptable” traffic operations;
3. Independent of the Project, it was noted that one or more movements at the Route 140/ King Street/Chestnut Street intersection are currently operating at or over capacity (defined as LOS “E” or “F”, respectively) during the weekday evening peak hour, with Project-related impacts at the intersection defined as an increase in average motorist delay of up to 10.7 seconds and in vehicle queuing of up to one (1) vehicle;

¹*Trip Generation*, 11th Edition; Institute of Transportation Engineers; Washington, DC; 2021.



4. All movements exiting the Project site driveway are predicted to operate at LOS C during the week-day morning peak hour and at LOS D during the weekday evening peak hour, with vehicle queues of up to one (1) vehicle. All movements along Route 140 approaching the Project site driveway are expected to operate at LOS A with negligible vehicle queuing;
5. No apparent safety deficiencies were identified based on a review of MassDOT motor vehicle crash data for the study area intersections; and
6. Lines of sight at the Project site driveway intersection with Route 140 were found to exceed the recommended minimum distance for the intersection to operate in a safe and efficient manner based on the appropriate approach speed.

In consideration of the above, we have concluded that the Project can be accommodated within the confines of the existing transportation infrastructure in a safe and efficient manner with the implementation of the recommendations defined herein.

The following details our assessment of the Project.

PROJECT DESCRIPTION

The Project will entail the construction of a three-story building to be located at 230 East Central Street (Route 140) in Franklin, Massachusetts, which will contain 35 multifamily residential units and 900± square feet (sf) of office space on the ground floor. The Project site encompasses approximately 1.0± acres of land bound by Route 140 to the north and residential properties and areas of open and wooded space to the south, east, and west. The Project site currently contains single-family homes and associated appurtenances that will be removed to accommodate the Project. Access to the Project site will be provided by way of a new driveway that will intersect the south side of Route 140 approximately 10 feet east of the existing driveway that serves the Project site, which will be closed in conjunction with the Project.



Imagery ©2022 Google



On-site parking will be provided for 44 vehicles, 42 of which will be provided for the residential use, or a parking ratio of 1.26 parking spaces per unit, and two (2) of which will be provided to support the office use, or 1 parking space per 450 sf. These parking ratios are below those required for the proposed uses as specified in Section 185-21, *Parking, Loading, and Driveway Requirements*, of the Zoning Bylaws of the Town of Franklin.²

STUDY METHODOLOGY

This study was prepared in consultation with the MassDOT and the Town of Franklin; was performed in accordance with MassDOT's *Transportation Impact Assessment (TIA) Guidelines* and the standards of the Traffic Engineering and Transportation Planning professions for the preparation of such reports; and was conducted in three distinct stages.

The first stage involved an assessment of existing conditions in the study area and included an inventory of roadway geometrics; pedestrian and bicycle facilities; on-street parking; public transportation services; observations of traffic flow; and collection of pedestrian, bicycle, and vehicle counts.

In the second stage of the study, future traffic conditions were projected and analyzed. Specific travel demand forecasts for the Project were assessed along with future traffic demands due to expected traffic growth independent of the Project. A seven-year time horizon was selected for analyses consistent with MassDOT guidelines. The analysis conducted in stage two identifies existing or projected future capacity, safety, and access issues, as these areas relate to the transportation infrastructure.

The third stage of the study presents and evaluates measures to address deficiencies in the transportation infrastructure, if any, identified in stage two of the study.

EXISTING CONDITIONS

A comprehensive field inventory of existing conditions within the study area was conducted in January 2022. This inventory included the collection of traffic-volume data and vehicle travel speed measurements, as well as a review of existing pedestrian and bicycle accommodations, public transportation services, and motor vehicle crash data. The following summarizes existing conditions within the study area.

Roadways

East Central Street (Route 140)

East Central Street (Route 140) is a two-lane, urban principal arterial roadway that traverses a general east-west direction and is under Town jurisdiction from a point just east of East Street to a point just west of Lewis Street, and under MassDOT jurisdiction to the east and west of these limits. In the vicinity of the Project site, Route 140 is under Town jurisdiction and provides two 18-foot-wide lanes that are separated by a double-yellow centerline with 2-foot wide marked shoulders. The posted speed limit in the vicinity of the Project site is 40 miles per hour (mph), with prevailing travel speeds measured in January 2022 found to be 34 mph in both directions.³ Sidewalks are provided continuously along both sides of the roadway

²In the Commercial I Zoning District, 1.5 parking spaces per residential unit is required and 1.0 parking spaces per 500 sf of gross floor area is required for commercial space.

³The prevailing travel speed is also known as the 85th percentile vehicle travel speed or the speed at which 85 percent of the observed vehicles traveled at or below during the observation period.



within the study area and illumination is provided by way of streetlights mounted on wood poles. Land use along Route 140 within the study area consists of the Project site and residential and commercial properties.

Intersections

Table 1 and Figure 1 summarize existing lane use, traffic control, and pedestrian and bicycle accommodations at the study area intersections as observed in July 2021.

Table 1
STUDY AREA INTERSECTION DESCRIPTION

Intersection	Traffic Control Type^a	No. of Travel Lanes Provided	Shoulder Provided? (Yes/No/Width)	Pedestrian Accommodations? (Yes/No/Description)	Bicycle Accommodations? (Yes/No/Description)
Rte. 140/ King St./ Chestnut St.	TS	1 left-turn lane and a shared through/right-turn lane on Rte. 140 approaches, with right-turn movements exiting prior to the intersection by way of a channelized lane; 1 shared left-turn/through lane and a right-turn lane on King St. northbound approach; 1 general-purpose travel lane on Chestnut St. southbound approach	Yes; 2 feet on Rte. 140; 4 feet on King St.	Yes – Sidewalks are provided along both sides of Rte. 140 and King St. and along the west side of Chestnut St. for approx. 200 lf; crosswalks provided across all legs of the intersection; pedestrian traffic signal equipment and phasing (exclusive) provided	Yes - Shared traveled-way ^b
Rte. 140/ Horace Mann Plaza Dwy/ CVS Dwy	TS	1 left-turn lane, 1 through travel lane and 1 right-turn lane on Rte. 140 approaches; 1 shared left-turn/through lane and a right-turn lane on Horace Mann Plaza Dwy. and CVS/Pharmacy Dwy.	Yes – 1 to 3 feet on all approaches	Yes – Sidewalks along both sides of Rte. 140 with crosswalks provided across the north, east and west legs of the intersection; pedestrian traffic signal equipment and phasing (exclusive) provided	Yes - Shared traveled-way

^aTS = traffic signal control.

^bCombined shoulder and travel lane width equal to or exceed 14 feet.

Existing Traffic Volumes

In order to determine existing traffic-volume demands within the study area, manual turning movement counts (TMCs) and vehicle classification counts were obtained from the May 2020 *Transportation Impact Assessment* that was prepared by VAI for the Central Square mixed-use development and included the study area intersections.⁴ The TMCs were collected on Thursday, March 5, 2020, while public schools were in regular session and prior to the implementation of the restrictions associated with the COVID-19 pandemic, and were performed during the weekday morning (7:00 to 9:00 AM) and evening (4:00 to 6:00 PM) peak

⁴*Transportation Impact Assessment*, Central Square Mixed-Use Development, 340 East Central Street, Franklin, Massachusetts; VAI; May 2020.



periods. These time periods were selected for analysis purposes as they are representative of the peak-traffic-volume hours for both the Project and the adjacent roadway network.

Traffic Volume Adjustments

As documented in the May 2020 *Transportation Impact Assessment* that was prepared for the Central Square mixed-use development, the March traffic volumes were adjusted upward by 7.0 percent in order to be representative of average-month conditions. This adjustment was determined based on a review of traffic-volume data from MassDOT Continuous Count Station No. 3180 located on Interstate 495 in Norfolk.⁵ In addition, the 2020 traffic volumes were adjusted to 2022 traffic-volume conditions by applying a background traffic growth rate of 1.0 percent per year (discussion follows in the *Future Conditions* section of this assessment). The 2022 Existing weekday morning and evening peak-hour traffic volumes are graphically depicted on Figure 1.

Pedestrian and Bicycle Facilities

Sidewalks are provided along both sides of Route 140, King Street, and Chestnut Street within the study area, with marked crosswalks provided for crossing one or more legs of the study area intersections that include pedestrian traffic signal equipment (pushbuttons and signal indications) and phasing. Formal bicycle facilities were not identified within the immediate study area; however, Route 140, King Street, and Chestnut Street generally provide sufficient width to accommodate bicycle travel in a shared traveled-way configuration (i.e., bicyclists and motor vehicles sharing the traveled way).⁶

Public Transportation

Regularly scheduled, fixed-route, public transportation services are not currently provided within the study area or to the Project site. The Greater Attleboro-Taunton Regional Transit Authority (GATRA) operates an on-demand microtransit service which allows transit riders to request a vehicle to pick them up for same-day service within the Town of Franklin through the GATRA GO United program. To the west of the Project site, the Massachusetts Bay Transportation Authority (MBTA) provides Commuter Rail service to South Station in Boston on the Franklin Line from Forge Park/495 Station, which is located at 1000 West Central Street (an approximate 9-minute driving distance from the Project site). Additionally, GATRA provides Dial-a-Ride paratransit services to eligible persons residing within the Town of Franklin who cannot use fixed-route transit all or some of the time due to a physical, cognitive, or mental disability in compliance with the Americans with Disabilities Act (ADA).

⁵MassDOT Traffic Volumes for the Commonwealth of Massachusetts; 2022.

⁶A minimum combined travel lane and paved shoulder width of 14 feet is required to support bicycle travel in a shared traveled-way condition.



WEEKDAY MORNING PEAK HOUR (7:45 - 8:45 AM)

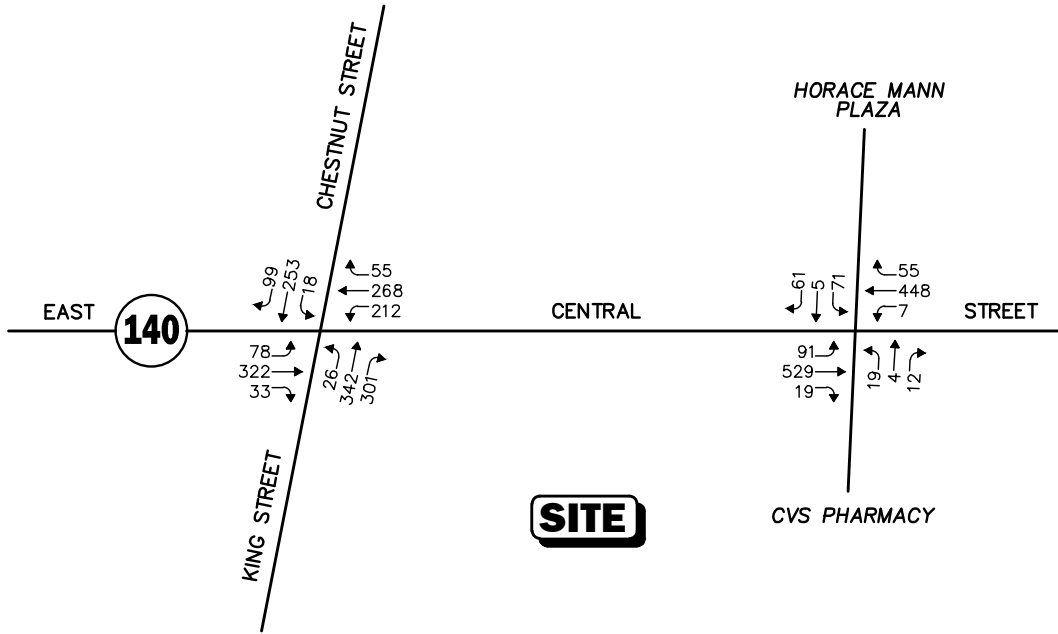

WEEKDAY EVENING PEAK HOUR (4:30 - 5:30 PM)

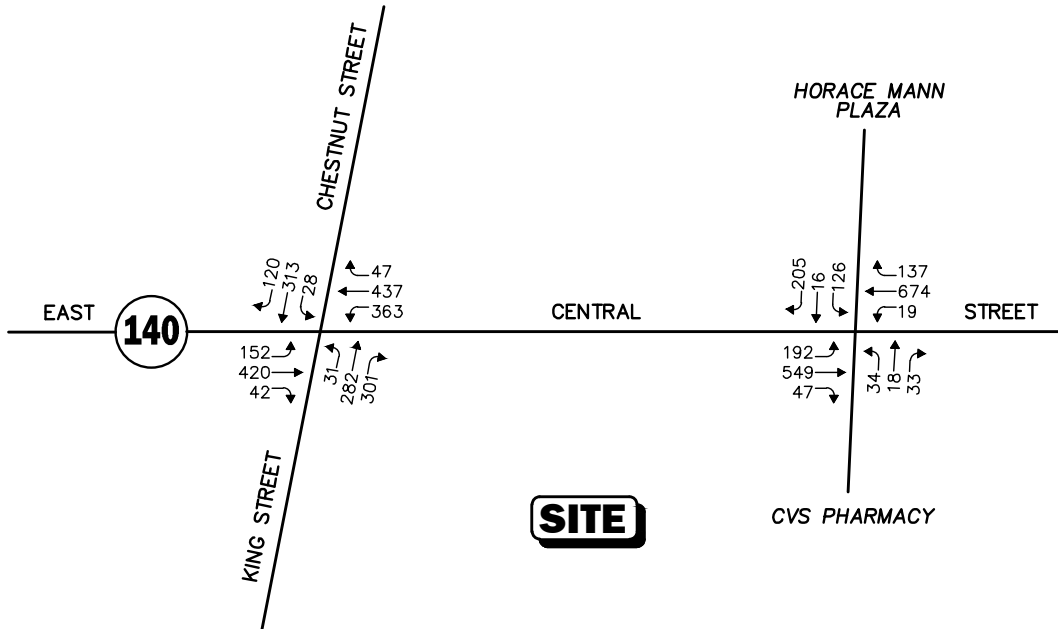

Not To Scale



Figure 1

2022 Existing Weekday Peak-Hour Traffic Volumes

Motor Vehicle Crash Data

Motor vehicle crash information for the study area intersections was provided by the MassDOT Highway Division Safety Management/Traffic Operations Unit for the most recent five-year period available (2015 through 2019, inclusive) to examine motor vehicle crash trends occurring within the study area. The data is summarized by intersection, type, severity, roadway and weather conditions, and day of occurrence, and is presented in Table 2.

As can be seen in Table 2, the study intersections experienced an average of approximately six (6) or fewer reported motor vehicle crashes per year over the five-year review period and were found to have a motor vehicle crash rate below both the MassDOT statewide and District averages for a signalized or unsignalized intersection, as appropriate, for the MassDOT Highway Division District in which the intersections are located (District 3). The majority of the reported crashes occurred on a weekday, under clear weather conditions during daylight, and involved rear-end or angle-type crashes that resulted in property damage only.

A review of the MassDOT statewide High Crash Location List indicated that none of the study intersections are included on MassDOT's Highway Safety Improvement Program (HSIP) listing as a high crash location. The detailed MassDOT Crash Rate Worksheets and high crash location mapping are provided in the Appendix.



Table 2
MOTOR VEHICLE CRASH DATA SUMMARY^a

	Route 140/ King St./ Chestnut St.	Route 140/ Horace Mann Plaza/ CVS/Pharmacy	Route 140/ 230 East Central Street
Traffic Control Type ^b	TS	TS	U
<i>Year:</i>			
2015	3	1	1
2016	10	6	4
2017	6	3	2
2018	4	2	0
<u>2019</u>	<u>6</u>	<u>2</u>	<u>1</u>
Total	29	14	8
Average	5.8	2.8	1.6
Crash Rate ^c	0.56	0.34	0.25
MassDOT Crash Rate: ^d	0.78/0.89	0.78/0.89	0.57/0.61
Significant? ^e	No	No	No
<i>Type:</i>			
Angle	8	4	4
Head-On	1	1	0
Rear-End	13	5	1
Rear-to-Rear	0	0	0
Sideswipe	5	1	2
Fixed Object	1	2	0
Pedestrian/Bicycle	1	0	1
<u>Unknown/Other</u>	<u>0</u>	<u>1</u>	<u>0</u>
Total	29	14	8
<i>Conditions:</i>			
Clear	19	12	6
Cloudy	4	0	2
Rain	3	2	0
Snow/Ice	1	0	0
<u>Not Reported/Other</u>	<u>2</u>	<u>0</u>	<u>0</u>
Total	29	14	8
<i>Lighting:</i>			
Daylight	22	14	7
Dawn/Dusk	2	0	0
Dark (Road Lit)	5	2	1
<u>Dark (Road Unlit)</u>	<u>0</u>	<u>0</u>	<u>0</u>
Total	29	14	8
<i>Day of Week:</i>			
Monday-Friday	25	12	7
Saturday	0	2	1
<u>Sunday</u>	<u>4</u>	<u>0</u>	<u>0</u>
Total	29	14	8
<i>Severity:</i>			
Property Damage Only	21	10	6
Non-fatal Injury	8	2	2
<u>Not Reported</u>	<u>0</u>	<u>2</u>	<u>0</u>
Total	29	14	8

^aSource: MassDOT Safety Management/Traffic Operations Unit records, 2015 through 2019.

^bTraffic Control Type: TS = traffic signal; U = unsignalized.

^cCrash rate per million vehicles entering the intersection.

^dStatewide/District crash rate.

^eThe intersection crash rate is significant if it is found to exceed the MassDOT crash rate for the MassDOT Highway Division District in which the Project is located (District 3).



FUTURE CONDITIONS

Traffic volumes in the study area were projected to the year 2029, which reflects a seven-year planning horizon consistent with MassDOT guidelines. Independent of the Project, traffic volumes on the roadway network in the year 2029 under No-Build conditions include all existing traffic and new traffic resulting from background traffic growth. Anticipated Project-generated traffic volumes superimposed upon the 2029 No-Build traffic volumes reflect 2029 Build traffic-volume conditions with the Project.

Future Traffic Growth

Future traffic growth is a function of the expected land development in the immediate area and the surrounding region. Several methods can be used to estimate this growth. A procedure frequently employed estimates an annual percentage increase in traffic growth and applies that percentage to all traffic volumes under study. The drawback to such a procedure is that some turning volumes may actually grow at either a higher or a lower rate at particular intersections.

An alternative procedure identifies the location and type of planned development, estimates the traffic to be generated, and assigns it to the area roadway network. This procedure produces a more realistic estimate of growth for local traffic; however, potential population growth and development external to the study area would not be accounted for in the resulting traffic projections.

To provide a conservative analysis framework, both procedures were used, the salient components of which are described below.

Specific Development by Others

The Town of Franklin Planning Department was consulted in order to determine if there were any projects planned within the study area that would have an impact on future traffic volumes at the study intersections. Based on this consultation, the following projects were identified for inclusion in this assessment:

- ***Central Square Mixed-Use Development, 340 East Central Street (Route 140), Franklin, Massachusetts.*** This project entails the construction of a mixed-use development that will include 104 multifamily residential units, 15,219± sf of retail space, and a 2,250± sf coffee shop with drive-through window. This project is currently under construction and portions are occupied; however, the project was not constructed at the time that the traffic counts that form the basis of this assessment were performed.
- ***Chestnut Senior Village, Chestnut Street, Franklin, Massachusetts.*** This project consists of the construction of 44 senior housing units to be located off Chestnut Street in Franklin, Massachusetts. Traffic volumes associated with this project within the study area are expected to be relatively minor and would be reflected in the general background traffic growth rate (discussion follows).

Traffic volumes associated with the Central Square mixed-use development were obtained from the TIA prepared for the project.⁷ No other developments were identified at this time that are expected to result in an increase in traffic within the study area beyond the general background traffic growth rate.

⁷Ibid 4.



General Background Traffic Growth

Traffic-volume data compiled by MassDOT from permanent count stations located in Franklin were reviewed in order to determine general traffic growth trends in the area. This data indicates that traffic volumes have fluctuated over the 10-year period between 2009 and 2019, with an average traffic growth rate of 0.57 percent per year. In order to provide a prudent planning condition for the Project, a slightly higher 1.0 percent per year compounded annual background traffic growth rate was used in order to account for future traffic growth, new trips associated with the Chestnut Village senior housing community and presently unforeseen development within the study area.

Roadway Improvement Projects

The Town of Franklin and MassDOT were contacted in order to determine if there were any planned future roadway improvement projects expected to be complete by 2029 within the study area. Based on these discussions, no roadway improvement projects aside from routine maintenance activities were identified to be planned within the study area at this time.

No-Build Traffic Volumes

The 2029 No-Build condition peak-hour traffic volumes were developed by applying the 1.0 percent per year compounded annual background traffic growth rate to the 2022 Existing peak-hour traffic volumes and then adding the peak-hour traffic volumes associated with the identified specific development project by others. The resulting 2029 No-Build weekday morning and evening peak-hour traffic volumes are shown on Figure 2.

Project-Generated Traffic

Design year (2029 Build) traffic volumes for the study area roadways were determined by estimating Project-generated traffic volumes and assigning those volumes on the study roadways. The following sections describe the methodology used to develop the anticipated traffic characteristics of the Project.

As proposed, the Project will entail the construction of a mixed-use building that will contain 35 multifamily residential units and 900± sf of office space on the ground floor. In order to develop the traffic characteristics of the Project, trip-generation statistics published by the ITE⁸ for a similar land use as that proposed were used. ITE Land Use Codes (LUCs) 220, *Multifamily Housing (Low-Rise)*, and 712, *Small Office Building*, were used to establish the traffic characteristics of the Project, the results of which are summarized in Table 3.

⁸Ibid 1.



WEEKDAY MORNING PEAK HOUR (7:45 - 8:45 AM)

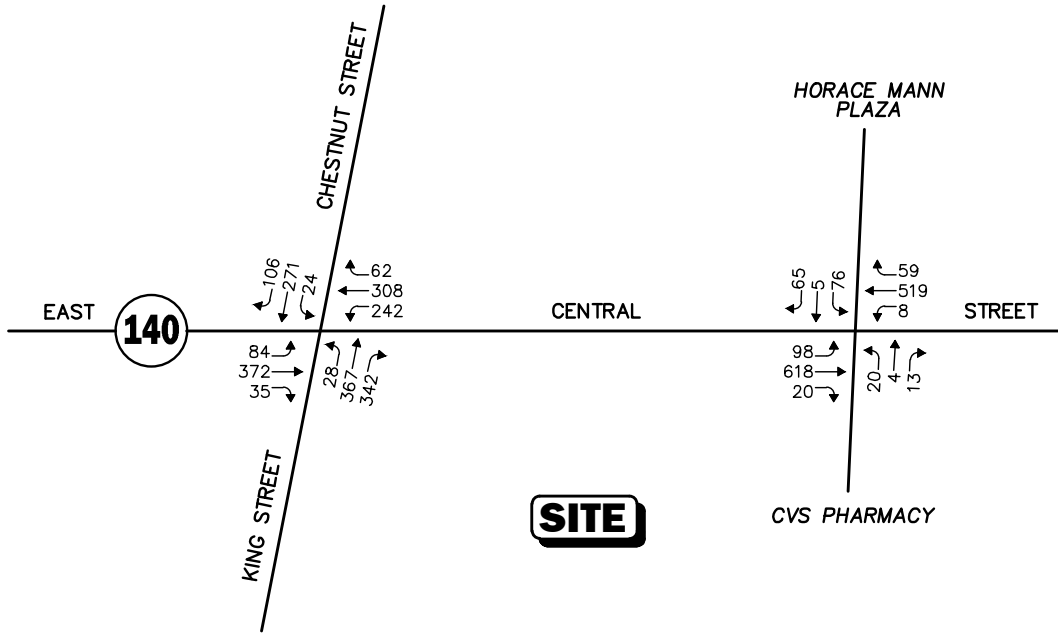

WEEKDAY EVENING PEAK HOUR (4:30 - 5:30 PM)

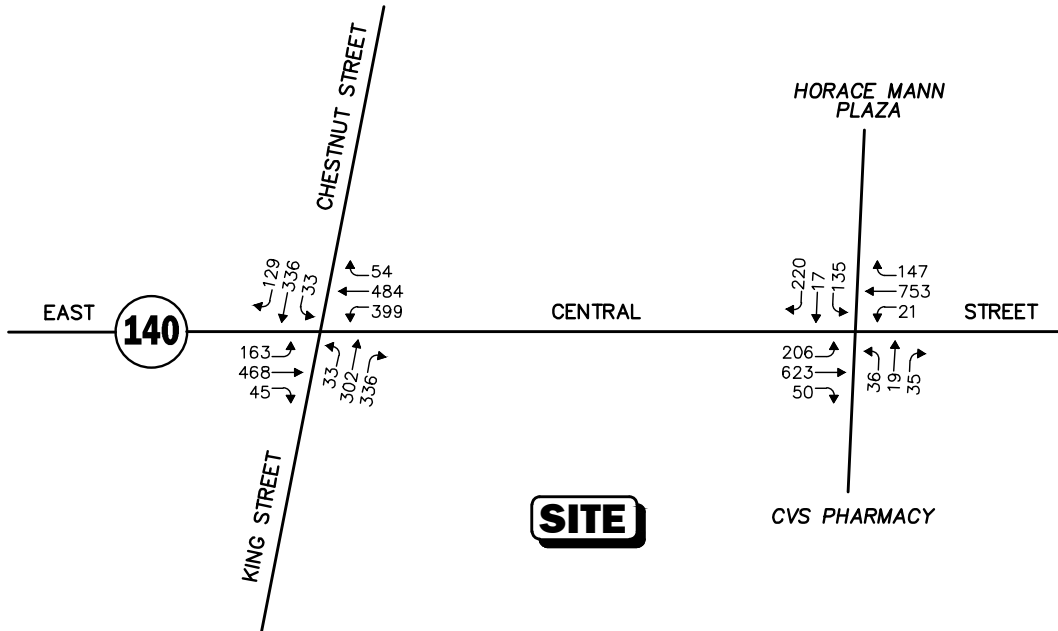

Not To Scale



Figure 2

2029 No-Build
Weekday
Peak-Hour Traffic Volumes

Table 3
TRIP-GENERATION SUMMARY

Time Period/Direction	Vehicle Trips		(A+B) Total
	(A) Residential Component (35 units) ^a	(B) Office Component (900 sf) ^a	
<i>Average Weekday Daily:</i>			
Entering	150	7	157
<u>Exiting</u>	<u>150</u>	<u>7</u>	<u>157</u>
Total	300	14	314
<i>Weekday Morning Peak Hour:</i>			
Entering	8	1	9
<u>Exiting</u>	<u>26</u>	<u>1</u>	<u>27</u>
Total	34	2	36
<i>Weekday Evening Peak Hour:</i>			
Entering	22	1	23
<u>Exiting</u>	<u>14</u>	<u>1</u>	<u>15</u>
Total	36	2	38

^aBased on ITE LUC 220, *Multifamily Housing (Low-Rise)*.

^bBased on ITE LUC 712, *Small Office Building*.

Project-Generated Traffic-Volume Summary

As can be seen in Table 3, the Project is expected to generate approximately 314 vehicle trips on an average weekday (two-way, 24-hour volume, or 157 vehicles entering and 157 exiting), with 36 vehicle trips (9 vehicles entering and 27 exiting) expected during the weekday morning peak-hour and 38 vehicle trips (23 vehicles entering and 15 exiting) expected during the weekday evening peak-hour.

Trip Distribution and Assignment

The directional distribution of generated trips to and from the Project site was determined based on a review of U.S. Census Journey-to-Work data for the Town of Franklin and then refined based on a review of existing traffic patterns within the study area. The general trip distribution for the Project is graphically depicted on Figure 3, with the additional traffic that is expected to be generated by the Project assigned on the study area roadway network as shown on Figure 4.

Build Traffic Volumes

The 2029 Build condition traffic volumes consist of the 2029 No-Build traffic volumes with the addition of the traffic expected to be generated by the Project. The 2029 Build weekday morning and evening peak-hour traffic volumes are graphically depicted on Figure 5.



Legend:

- XX Entering Trips
- (XX) Exiting Trips

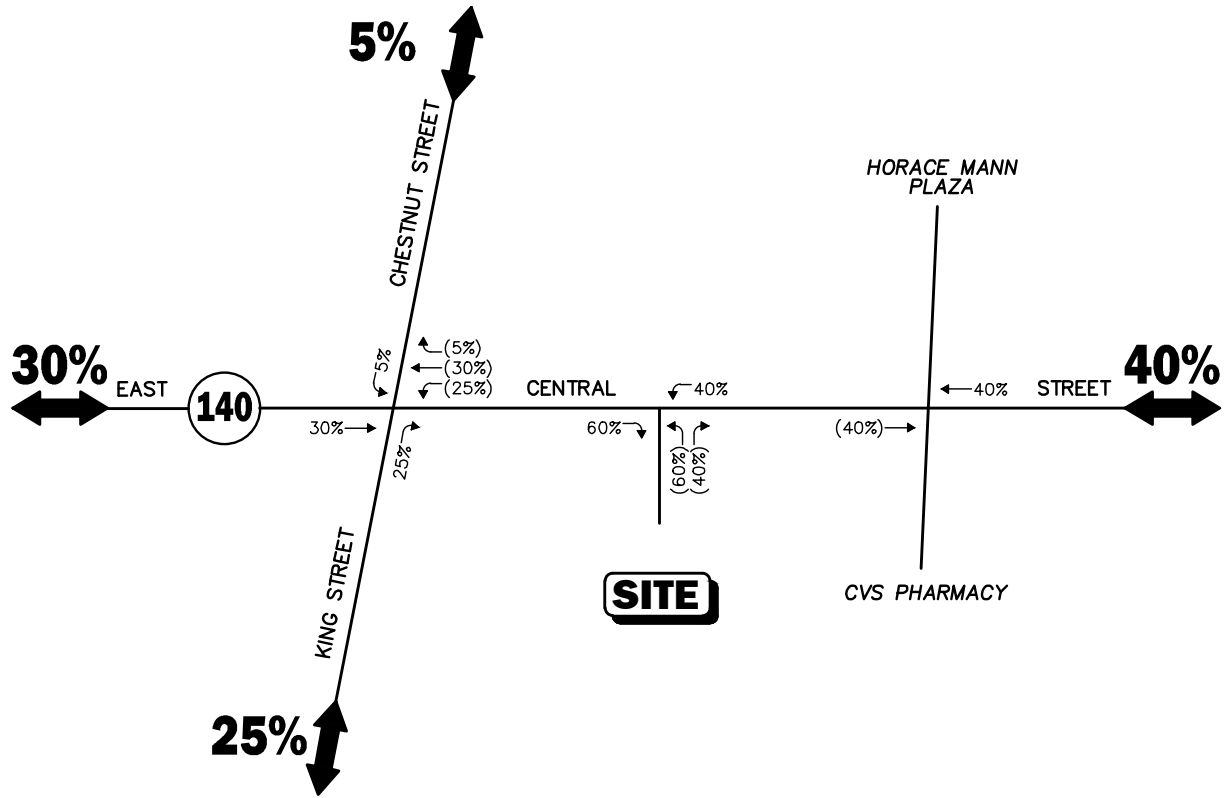

Not To Scale

Figure 3
Trip Distribution Map



R:\9217\9217NT2.dwg, 1/18/2022 12:01:59 PM

WEEKDAY MORNING PEAK HOUR (7:45 - 8:45 AM)

Legend:
 XX Entering Trips
 (XX) Exiting Trips

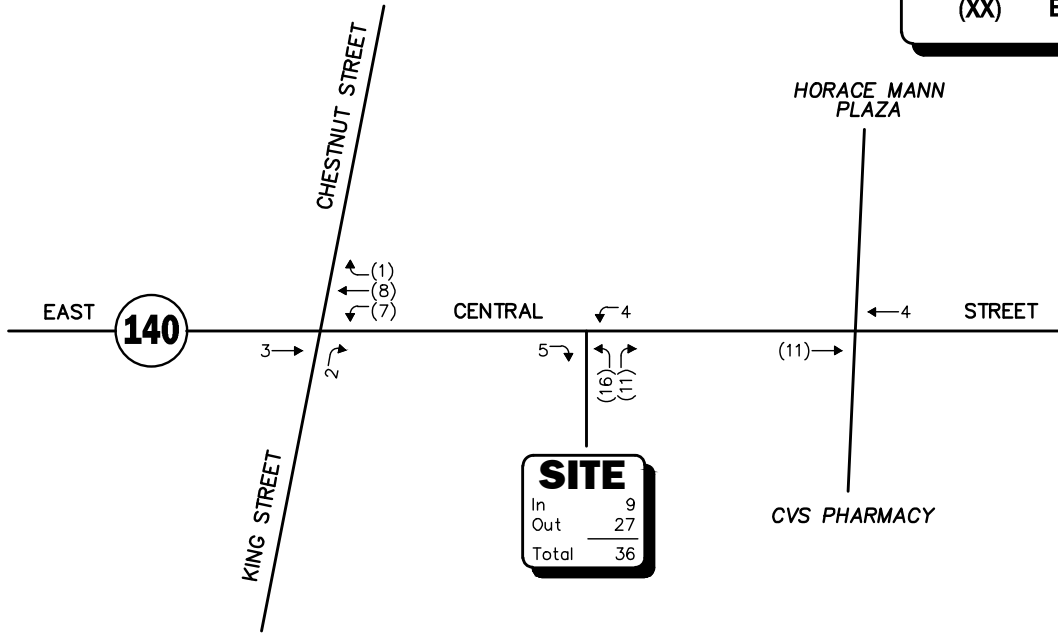

WEEKDAY EVENING PEAK HOUR (4:30 - 5:30 PM)

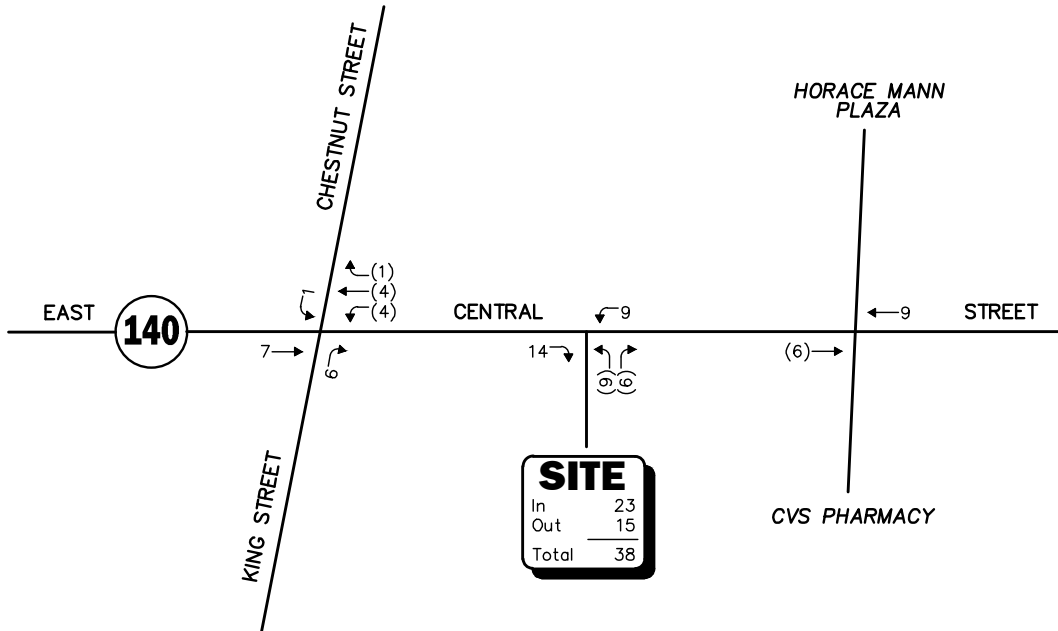

Not To Scale



Figure 4
 Project-Generated
 Weekday
 Peak-Hour Traffic Volumes

R:\9217\9217NT2.dwg, 1/18/2022 12:35:58 PM

WEEKDAY MORNING PEAK HOUR (7:45 - 8:45 AM)

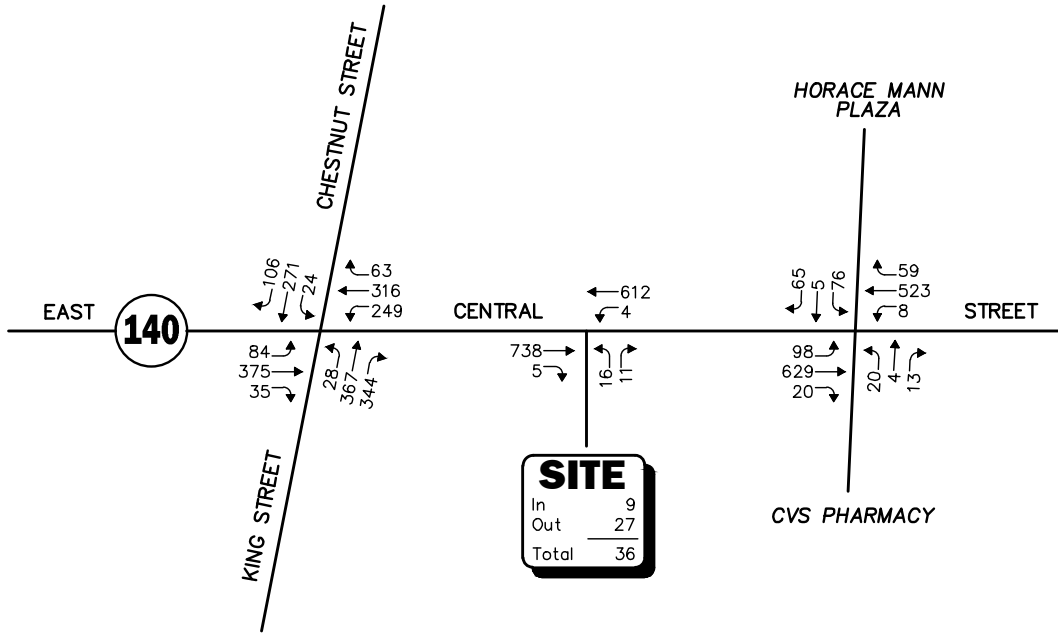

WEEKDAY EVENING PEAK HOUR (4:30 - 5:30 PM)

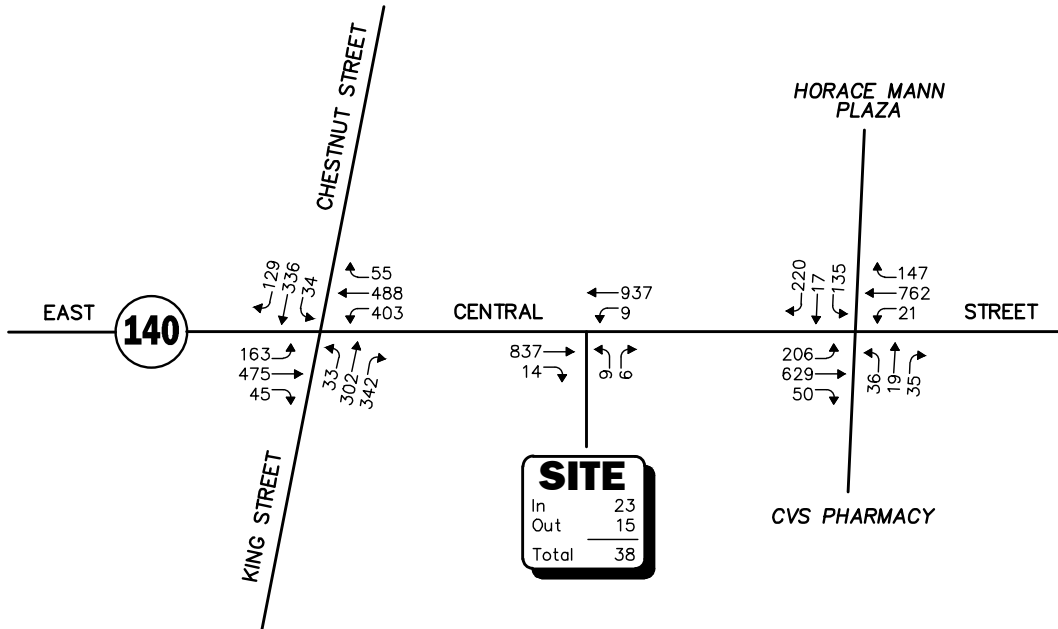

Not To Scale



Figure 5

2029 Build
Weekday
Peak-Hour Traffic Volumes

TRAFFIC OPERATIONS ANALYSIS

In order to assess the potential impact of the Project on the roadway network, a detailed traffic operations analysis (motorist delays, vehicle queuing, and level-of-service) was performed for the study intersections. Capacity analyses provide an indication of how well transportation facilities serve the traffic demands placed upon them, with vehicle queue analyses providing a secondary measure of the operational characteristics of an intersection or section of roadway under study.

In brief, six levels of service are defined for each type of facility. They are given letter designations ranging from A to F, with LOS “A” representing the best operating conditions and LOS “F” representing congested or constrained operations. An LOS of “E” is representative of a transportation facility that is operating at its design capacity with an LOS of “D” generally defined as the limit of “acceptable” traffic operations. Since the level-of-service of a traffic facility is a function of the flows placed upon it, such a facility may operate at a wide range of levels of service depending on the time of day, day of week, or period of the year. The Synchro® intersection capacity analysis software, which is based on the analysis methodologies and procedures presented in the 2010 *Highway Capacity Manual* (HCM)⁹ for unsignalized intersections, was used to complete the level-of-service and vehicle queue analyses.

Analysis Results

Level-of-service and vehicle queue analysis were conducted for 2022 Existing, 2029 No-Build, and 2029 Build conditions for the intersections within the study area. The results of the intersection capacity and vehicle queue analyses are summarized in Table 4, with the detailed analysis results attached.

The addition of Project-related traffic to the study area intersections is not predicted to result in a significant increase in motorist delays or vehicle queuing over No-Build conditions; however, independent of the Project, specific movements at the Route 140/King Street/Chestnut Street intersection were identified as operating at or over capacity (i.e., LOS of “E” or “F”, respectively) during weekday evening peak hour.

The following is a summary of the level-of-service and vehicle queue analysis results. For context, we note that an LOS of “D” or better is generally defined as “acceptable” operating conditions.

Signalized Intersections

Project-related impacts at the signalized study area intersection are shown in Table 4 and are defined as follows:

Route 140 at King Street and Chestnut Street

The addition of Project-related traffic to this intersection was shown to result in the following impacts over No-Build conditions: *weekday morning peak-hour* – the Chestnut Street approach was shown to degrade from LOS C to LOS D as a result of a predicted increase in average motorist delay of 1.4 seconds; *weekday evening peak-hour* – overall intersection operations were shown to degrade from LOS E to LOS F as a result of a predicted increase in overall motorist delay of 3.7 seconds. Vehicle queues at the intersection were shown to increase by up to one (1) vehicle with the addition of Project-related traffic.

⁹*Highway Capacity Manual*, Transportation Research Board; Washington, DC; 2010.



Route 140 at the Horace Mann Plaza Driveway and the CVS/Pharmacy® Driveway

No changes in overall level of service was shown to occur over No-Build conditions, with a minor change in level of service identified for Route 140 through movements during the weekday evening peak hour, where the level of service was shown to degrade from LOS C to LOS D as a result of a predicted increase in average motorist delay of 1.5 seconds. Vehicle queues at the intersection were shown to increase by up to one (1) vehicle with the addition of Project-related traffic.

Unsignalized Intersection

Project-related impacts at the unsignalized study area intersection are shown in Table 5, and are defined as follows:

Route 140 at the Project Site Driveway

All movements exiting the Project site driveway are predicted to operate at LOS C during the weekday morning peak hour and at LOS D during the weekday evening peak hour, with vehicle queues of up to one (1) vehicle. All movements along Route 140 approaching the Project site driveway are expected to operate at LOS A with negligible vehicle queuing.



Table 4
SIGNALIZED INTERSECTION LEVEL-OF-SERVICE AND VEHICLE QUEUE SUMMARY

Signalized Intersection/ Peak Hour/Movement	2022 Existing				2029 No-Build				2029 Build			
	V/C ^a	Delay ^b	LOS ^c	Queue ^d 50 th /95 th	V/C	Delay	LOS	Queue 50 th /95 th	V/C	Delay	LOS	Queue 50 th /95 th
Route 140 at King Street and Chestnut Street												
<i>Weekday Morning:</i>												
Route 140 EB LT	0.22	19.0	B	1/3	0.24	19.0	B	1/3	0.24	19.0	B	1/3
Route 140 EB TH/RT	0.76	35.7	D	7/15	0.80	37.8	D	8/19	0.80	38.1	D	9/19
Route 140 WB LT	0.59	19.0	B	3/6	0.67	22.0	C	3/7	0.69	22.8	C	3/8
Route 140 WB TH/RT	0.55	25.1	C	5/12	0.57	25.1	C	6/14	0.58	25.1	C	6/14
King Street NB LT/TH	0.66	26.4	C	7/19	0.77	33.4	C	8/21	0.77	34.3	C	8/21
King Street NB RT	0.29	13.2	B	1/6	0.35	15.2	B	2/7	0.35	15.4	B	2/7
Chestnut Street SB LT/TH/RT	0.57	23.7	C	138/385	0.77	33.9	C	8/22	0.79	35.3	D	8/22
Overall	--	24.3	C	--	--	28.4	C	--	--	29.0	C	--
<i>Weekday Evening:</i>												
Route 140 EB LT	0.48	20.2	C	2/5	0.54	21.1	C	2/5	0.55	21.2	C	2/5
Route 140 EB TH/RT	0.86	43.3	D	10/22	0.87	43.5	D	12/26	0.88	44.3	D	12/26
Route 140 WB LT	1.04	>80.0	F	7/20	1.20	>80.0	F	10/23	1.23	>80.0	F	10/24
Route 140 WB TH/RT	0.77	33.0	C	10/24	0.81	34.4	C	12/27	0.81	34.7	C	12/28
King Street NB LT/TH	0.72	34.8	C	7/17	0.86	50.0	D	8/19	0.87	50.7	D	8/19
King Street NB RT	0.27	15.4	B	1/5	0.32	17.8	B	2/16	0.32	18.0	B	2/6
Chestnut Street SB LT/TH/RT	0.97	63.1	E	13/24	1.29	>80.0	F	18/29	1.31	>80.0	F	18/30
Overall	--	45.5	D	--	--	79.4	E	--	--	>80.0	F	--

See notes at end of table.



Table 4 (Continued)
SIGNALIZED INTERSECTION LEVEL-OF-SERVICE AND VEHICLE QUEUE SUMMARY

Signalized Intersection/ Peak Hour/Movement	2022 Existing				2029 No-Build				2029 Build			
	V/C ^a	Delay ^b	LOS ^c	Queue ^d 50 th /95 th	V/C	Delay	LOS	Queue 50 th /95 th	V/C	Delay	LOS	Queue 50 th /95 th
Route 140 at Horace Mann Plaza Driveway and CVS/Pharmacy Driveway												
<i>Weekday Morning:</i>												
Route 140 EB LT	0.23	5.9	A	1/2	0.26	6.4	A	1/3	0.26	6.4	A	1/3
Route 140 EB TH	0.61	10.0	A	3/17	0.65	10.2	B	4/24	0.66	10.4	B	4/25
Route 140 EB RT	0.01	6.2	A	0/0	0.01	6.2	A	0/0	0.01	6.2	A	0/0
Route 140 WB LT	0.02	8.1	A	0/1	0.03	8.1	A	0/1	0.03	8.1	A	0/1
Route 140 WB TH	0.61	13.1	B	5/15	0.62	13.1	B	6/19	0.62	13.1	B	6/19
Route 140 WB RT	0.04	8.9	A	0/0	0.04	8.9	A	0/1	0.04	8.9	A	0/1
CVS/Pharmacy Driveway NB LT/TH	0.18	24.7	C	1/2	0.20	30.1	C	1/2	0.20	30.4	C	1/2
CVS/Pharmacy Driveway NB RT	0.01	24.0	C	0/0	0.01	29.3	C	0/0	0.01	29.5	C	0/0
Horace Mann Plaza Driveway SB LT/TH	0.55	27.9	C	1/4	0.62	36.9	D	1/4	0.62	37.3	D	1/4
Horace Mann Plaza Driveway SB RT	0.04	19.3	B	0/1	0.05	24.2	C	0/1	0.05	24.5	C	0/1
Overall	--	12.6	B	--	--	13.3	B	--	--	13.3	B	--
<i>Weekday Evening:</i>												
Route 140 EB LT	0.55	13.9	B	1/6	0.68	27.2	C	2/8	0.68	27.5	C	2/8
Route 140 EB TH	0.53	10.3	B	4/19	0.60	11.7	B	5/23	0.61	11.8	B	5/23
Route 140 EB RT	0.03	7.0	A	0/0	0.03	7.2	A	0/0	0.03	7.2	A	0/0
Route 140 WB LT	0.05	10.1	B	0/1	0.06	10.6	B	0/1	0.06	10.6	B	0/1
Route 140 WB TH	0.81	24.4	C	12/53	0.91	34.4	C	14/38	0.92	35.9	D	15/39
Route 140 WB RT	0.12	12.1	B	1/3	0.14	12.5	B	1/3	0.14	12.5	B	1/3
CVS/Pharmacy Driveway NB LT/TH	0.31	34.8	C	1/3	0.32	34.8	C	1/3	0.32	34.8	C	1/3
CVS/Pharmacy Driveway NB RT	0.02	33.0	C	0/0	0.02	33.0	C	0/0	0.02	33.0	C	0/0
Horace Mann Plaza Driveway SB LT/TH	0.75	49.4	D	3/7	0.78	52.2	D	3/7	0.78	52.2	D	3/7
Horace Mann Plaza Driveway SB RT	0.13	24.4	C	0/2	0.14	24.4	C	0/2	0.14	24.4	C	0/2
Overall	--	20.4	C	--	--	25.5	C	--	--	26.0	C	--

^aVolume-to-capacity ratio.

^bControl (signal) delay per vehicle in seconds.

^cLevel of service.

^dQueue length in vehicles.

NB = northbound; SB = southbound; EB = eastbound; WB = westbound; UT = u-turning movements; LT = left-turning movements; TH = through movements; RT = right-turning movements.



Table 5
UNSIGNALIZED INTERSECTION LEVEL-OF-SERVICE AND VEHICLE QUEUE SUMMARY

Unsignalized Intersection/Peak Hour/Movement	2022 Existing				2029 No-Build				2029 Build			
	Demand ^a	Delay ^b	LOS ^c	Queue ^d 95 th	Demand	Delay	LOS	Queue 95 th	Demand	Delay	LOS	Queue 95 th
Route 140 at the Project Site Driveway												
Weekday Morning:												
Route 140 EB TH RT	--	--	--	--	--	--	--	--	743	0.0	A	0
Route 140 WB LT/TH	--	--	--	--	--	--	--	--	616	0.1	A	0
Project Driveway NB LT/RT	--	--	--	--	--	--	--	--	27	18.3	C	1
Weekday Evening:												
Route 140 EB TH RT	--	--	--	--	--	--	--	--	851	0.0	A	0
Route 140 WB LT/TH	--	--	--	--	--	--	--	--	946	0.5	A	0
Project Driveway NB LT/RT	--	--	--	--	--	--	--	--	15	27.7	D	1

^aDemand in vehicles per hour.

^bAverage control delay per vehicle (in seconds).

^cLevel of service.

^dQueue length in vehicles.

NB = northbound; EB = eastbound; WB = westbound; LT = left-turning movements; TH = through movements; RT = right-turning movements.



SIGHT DISTANCE ASSESSMENT

Sight distance measurements were performed at the Project site driveway intersection with Route 140 in accordance with MassDOT and American Association of State Highway and Transportation Officials (AASHTO)¹⁰ requirements. Both stopping sight distance (SSD) and intersection sight distance (ISD) measurements were performed. In brief, SSD is the distance required by a vehicle traveling at the design speed of a roadway, on wet pavement, to stop prior to striking an object in its travel path. ISD or corner sight distance (CSD) is the sight distance required by a driver entering or crossing an intersecting roadway to perceive an oncoming vehicle and safely complete a turning or crossing maneuver with on-coming traffic. In accordance with AASHTO standards, if the measured ISD is at least equal to the required SSD value for the appropriate design speed, the intersection can operate in a safe manner. Table 6 presents the measured SSD and ISD at the subject intersection.

Table 6
SIGHT DISTANCE MEASUREMENTS^a

Intersection/Sight Distance Measurement	Feet		
	Required Minimum (SSD)	Desirable (ISD) ^b	Measured
<i>Route 140 at the Project Site Driveway</i>			
<i>Stopping Sight Distance:</i>			
Route 140 approaching from the east	305	--	650+
Route 140 approaching from the west	305	--	650+
<i>Intersection Sight Distance:</i>			
Looking to the east from the driveway	305	445	650+
Looking to the west from the driveway	305	390	650+

^aRecommended minimum values obtained from *A Policy on Geometric Design of Highways and Streets*, 7th Edition; American Association of State Highway and Transportation Officials (AASHTO); 2018; and based on a 40 mph approach speed on Route 140.

^bValues shown are the intersection sight distance for a vehicle turning right or left exiting a roadway under STOP control such that motorists approaching the intersection on the major street should not need to adjust their travel speed to less than 70 percent of their initial approach speed.

As can be seen in Table 6, the available lines of sight at the Project site driveway intersection were found to exceed the recommended minimum sight distance to function in a safe (SSD) and efficient (ISD) manner based on a 40 mph approach speed along Route 140, which is consistent with the posted speed limit in the vicinity of the Project site (40 mph) and is 6 mph above the measured 85th percentile vehicle travel speed (34 mph).

¹⁰ *A Policy on Geometric Design of Highway and Streets*, 7th Edition; American Association of State Highway and Transportation Officials (AASHTO); Washington D.C.; 2018.



SUMMARY

VAI has completed a detailed assessment of the potential impacts on the transportation infrastructure associated with the proposed construction of the TAJ Estates of Franklin II mixed-use development to be located at 230 East Central Street (Route 140) in Franklin, Massachusetts. The following specific areas have been evaluated as they relate to the Project: i) access requirements; ii) potential off-site improvements; and iii) safety considerations; under existing and future conditions, both with and without the Project. Based on this assessment, we have concluded the following with respect to the Project:

1. Using trip-generation statistics published by the ITE¹¹ for similar land uses as those proposed, the Project is expected to generate approximately 314 vehicle trips on an average weekday (two-way, 24-hour volume), with 36 vehicle trips expected during the weekday morning peak-hour and 38 vehicle trips expected during the weekday evening peak-hour;
2. The Project will not result in a significant impact (increase) on motorist delays or vehicle queuing over anticipated future conditions without the Project (No-Build condition), with the majority of the movements at the study intersections shown to continue to operate at LOS D or better, where an LOS of “D” or better is defined as “acceptable” traffic operations;
3. Independent of the Project, it was noted that one or more movements at the Route 140/ King Street/Chestnut Street intersection are currently operating at or over capacity (defined as LOS “E” or “F”, respectively) during the weekday evening peak hour, with Project-related impacts at the intersection defined as an increase in average motorist delay of up to 10.7 seconds and in vehicle queuing of up to one (1) vehicle;
4. All movements exiting the Project site driveway are predicted to operate at LOS C during the weekday morning peak hour and at LOS D during the weekday evening peak hour, with vehicle queues of up to one (1) vehicle. All movements along Route 140 approaching the Project site driveway are expected to operate at LOS A with negligible vehicle queuing;
5. No apparent safety deficiencies were identified based on a review of MassDOT motor vehicle crash data for the study area intersections; and
6. Lines of sight at the Project site driveway intersection with Route 140 were found to exceed the recommended minimum distance for the intersection to operate in a safe and efficient manner based on the appropriate approach speed.

In consideration of the above, we have concluded that the Project can be accommodated within the confines of the existing transportation infrastructure in a safe and efficient manner with the implementation of the recommendations that follow.

RECOMMENDATIONS

A detailed transportation improvement program has been developed that is designed to provide safe and efficient access to the Project site and address any deficiencies identified as a part of this assessment. The following improvements have been recommended as a part of this evaluation and, where applicable, will be completed in conjunction with the Project subject to receipt of all necessary rights, permits, and approvals.

¹¹Ibid 1.



Project Access

Access to the Project site will be provided by way of a new driveway that will intersect the south side of Route 140 approximately 10 feet east of the existing driveway that serves the Project site, which will be closed in conjunction with the Project. The following recommendations are offered with respect to the design and operation of the Project site access and internal circulation, many of which are reflected on the Site Plans:

- The Project site driveway and internal circulating drives should be 24 feet in width and designed to accommodate the turning and maneuvering requirements of the largest anticipated responding emergency vehicle.
- Vehicles exiting the Project site should be placed under STOP-sign control with a marked STOP-line provided.
- Where perpendicular parking is proposed, the drive aisle behind the parking should be a minimum of 23-feet in width.
- All signs and pavement markings to be installed within the Project site should conform to the applicable standards of the *Manual on Uniform Traffic Control Devices (MUTCD)*.¹²
- A sidewalk has been provided within the Project site that links the proposed building to the sidewalk along Route 140.
- Americans with Disabilities Act (ADA)-compliant wheelchair ramps should be provided for crossing the Project site driveway and at pedestrian crossing within the Project site, or the driveway should be designed so that the sidewalk crosses the driveway (i.e., pan-type driveway).
- Signs and landscaping to be installed as a part of the Project within the intersection sight triangle areas of Athens Street and at intersections internal to the Project site should be designed and maintained so as not to restrict lines of sight.
- Snow accumulations (windrows) within sight triangle areas should be promptly removed where such accumulations would impede sightlines.

Off-Site

Route 140 at King Street and Chestnut Street

Independent of the Project, one or more movements at the Route 140/King Street/Chestnut Street intersection are currently operating at or over capacity (defined as LOS “E” or “F”, respectively) during the weekday evening peak hour, with Project-related impacts at the intersection defined as an increase in average motorist delay of up to 10.7 seconds and in vehicle queueing of up to one (1) vehicle, neither of which are significant. In order to improve operating conditions at the intersection, an optimal traffic signal timing plan should be considered for advancement independent of the Project. As can be seen in Table 7, with implementation of an optimal traffic signal timing plan, overall intersection operations were shown to improve to LOS E (from LOS F) during the weekday evening peak hour, with a general reduction in motorist delay.

¹²*Manual on Uniform Traffic Control Devices (MUTCD)*; Federal Highway Administration; Washington, D.C.; 2009.



Table 7
MITIGATED SIGNALIZED INTERSECTION LEVEL-OF-SERVICE AND VEHICLE QUEUE SUMMARY

Signalized Intersection/ Peak Hour/Movement	2029 No-Build				2029 Build				2029 Build with Mitigation			
	V/C ^a	Delay ^b	LOS ^c	Queue ^d 50 th /95 th	V/C	Delay	LOS	Queue 50 th /95 th	V/C	Delay	LOS	Queue 50 th /95 th
Route 140 at King Street and Chestnut Street												
<i>Weekday Morning:</i>												
Route 140 EB LT	0.24	19.0	B	1/3	0.24	19.0	B	1/3	0.24	19.0	B	1/3
Route 140 EB TH/RT	0.80	37.8	D	8/19	0.80	38.1	D	9/19	0.80	38.1	D	9/19
Route 140 WB LT	0.67	22.0	C	3/7	0.69	22.8	C	3/8	0.69	22.8	C	3/8
Route 140 WB TH/RT	0.57	25.1	C	6/14	0.58	25.1	C	6/14	0.58	25.1	C	6/14
King Street NB LT/TH	0.77	33.4	C	8/21	0.77	34.3	C	8/21	0.77	34.3	C	8/21
King Street NB RT	0.35	15.2	B	2/7	0.35	15.4	B	2/7	0.35	15.4	B	2/7
Chestnut Street SB LT/TH/RT	0.77	33.9	C	8/22	0.79	35.3	D	8/22	0.79	35.3	D	8/22
Overall	--	28.4	C	--	--	29.0	C	--	--	29.0	C	--
<i>Weekday Evening:</i>												
Route 140 EB LT	0.54	21.1	C	2/5	0.55	21.2	C	2/5	0.59	24.4	C	2/5
Route 140 EB TH/RT	0.87	43.5	D	12/26	0.88	44.3	D	12/26	0.98	68.9	E	13/28
Route 140 WB LT	1.20	>80.0	F	10/23	1.23	>80.0	F	10/24	1.15	>80.0	F	10/24
Route 140 WB TH/RT	0.81	34.4	C	12/27	0.81	34.7	C	12/28	0.86	40.9	D	12/30
King Street NB LT/TH	0.86	50.0	D	8/19	0.87	50.7	D	8/19	0.78	40.0	D	8/18
King Street NB RT	0.32	17.8	B	2/6	0.32	18.0	B	2/6	0.30	15.6	B	2/5
Chestnut Street SB LT/TH/RT	1.29	>80.0	F	18/29	1.31	>80.0	F	18/30	1.16	>80.0	F	17/28
Overall	--	79.4	E	--	--	>80.0	F	--	--	70.1	E	--

^aVolume-to-capacity ratio.

^bControl (signal) delay per vehicle in seconds.

^cLevel of service.

^dQueue length in vehicles.

NB = northbound; SB = southbound; EB = eastbound; WB = westbound; UT = u-turning movements; LT = left-turning movements; TH = through movements; RT = right-turning movements.



Transportation Demand Management

Regularly scheduled, fixed-route, public transportation services are not currently provided within the study area or to the Project site. GATRA operates an on-demand microtransit service which allows transit riders to request a vehicle to pick them up for same-day service within the Town of Franklin through the GATRA GO United program. To the west of the Project site, the MBTA provides Commuter Rail service to South Station in Boston on the Franklin Line from Forge Park/495 Station, which is located at 1000 West Central Street (an approximate 9-minute driving distance from the Project site). Additionally, GATRA provides Dial-a-Ride paratransit services to eligible persons residing within the Town of Franklin who cannot use fixed-route transit all or some of the time due to a physical, cognitive, or mental disability in accordance ADA requirements.

In an effort to reduce the overall number of automobile trips in the area and to integrate the Project into the available transportation resources, the following Transportation Demand Management (TDM) measures will be implemented as a part of the Project:

- A transportation coordinator, who may also have other operations/management responsibilities, will be assigned for the Project to coordinate the TDM program;
- Information regarding public transportation services, maps, schedules, and fare information will be posted in a central location and/or otherwise made available to residents and employees;
- A “welcome packet” will be provided to residents and employees detailing available public transportation services, bicycle and walking alternatives, and commuter options;
- Pedestrian accommodations will be incorporated into the Project and consist of sidewalks and ADA-compliant wheelchair ramps at all pedestrian crossings where a sidewalk is present;
- An internal mailroom will be provided; and
- Secure bicycle parking will be provided within the Project site consisting of: i) exterior bicycle parking conveniently located proximate to building entrance; and ii) weather protected bicycle parking located in a secure area within the building.

With the implementation of the above recommendations, safe and efficient access can be provided to the Project site and the Project can be accommodated within the confines of the existing transportation infrastructure.

cc: File



ATTACHMENTS

PROJECT SITE PLAN
MANUAL TURNING MOVEMENT COUNT DATA
SEASONAL ADJUSTMENT DATA
VEHICLE TRAVEL SPEED DATA
MASSDOT CRASH RATE WORKSHEETS AND HIGH CRASH
LOCATION MAPPING
BACKGROUND DEVELOPMENT NETWORKS
GENERAL BACKGROUND TRAFFIC GROWTH
TRIP-GENERATION CALCULATIONS
CAPACITY ANALYSIS WORKSHEETS



PROJECT SITE PLAN



- NOTES:
1. ALL SIGNAGE AND STRIPING TO CONFORM TO THE MANUAL FOR UNIFORM TRAFFIC CONTROL DEVICES.
 2. THE FIRE PROTECTION ENGINEER WILL PROVIDE PLANS AND CALCULATIONS FOR THE FIRE PROTECTION SYSTEM.
 3. ALL EROSION CONTROL DEVICES SHALL BE IN PLACE PRIOR TO CONSTRUCTION.
 4. THE OWNER/APPLICANT SHALL LIMIT CONSTRUCTION DEBRIS AND MATERIALS ON THE SITE IN THE EVENT THAT DEBRIS IS CARRIED OUT ONTO THE PUBLIC WAY. THE OWNER/APPLICANT SHALL BE RESPONSIBLE FOR ALL CLEANUP OF THE ROADWAY.

ZONING DISTRICT COMMERCIAL I⁷

	REQUIRED	EXISTING	PROPOSED
MIN. LOT AREA	5,000 SF	43,756±SF (1,005±AC)	43,756±SF (1,005±AC)
MIN. LOT FRONTAGE	50 FT	114.09 FT	114.09 FT
MIN. LOT DEPTH	50 FT	323.31 FT	323.31 FT
MIN. LOT WIDTH	45 FT	135.60 FT	135.60 FT
BLDG HEIGHT	3 STORES/40 FT ¹⁵	2 STY	3 STY.
MAX. % OF LOT UPLAND COVERED BY STRUCTURES & PAVING	80	1,742±SF (3.5%)	12,210±SF (27.9%)
	90+*	3,930±SF (7.9%)	35,196±SF (80.4%)

MIN. YARD SETBACKS	FRONT	REAR	SIDE
	20 FT ¹	15 FT	10 FT ¹⁴
	11.0 FT	19.1 FT	27.8/53.8 FT
	15 FT	237.6 FT	116.6 FT

- 1 BUT NO NEW STRUCTURES SHALL BE REQUIRED TO PROVIDE A DEEPER YARD THAN THAT EXISTING ON THAT PARCEL UPON ADOPTION OF THIS AMENDMENT.
- 2 PERMITTED RESIDENTIAL USES MUST OBSERVE REQUIREMENTS OF BUILDINGS ONLY. RESIDENTIAL USES PERMITTED ON RESIDENTIAL USE BUILDINGS ONLY. RESIDENTIAL USE BUILDINGS ARE EXEMPT FROM THIS REQUIREMENT.
- 3 THE 10 FT SIDE SETBACK IS ONLY REQUIRED ON ONE SIDE OF LOT. IF LOT ABUTS A RESIDENTIAL DISTRICT A 20 FT SETBACK IS REQUIRED ON THE ABUTTING SIDE.
- 4 BUILDINGS UP TO 50 FEET IN HEIGHT, REGARDLESS OF THE NUMBER OF STORES, MAY BE PERMITTED BY SPECIAL PERMIT FROM THE PLANNING BOARD.
- 5 NON-RESIDENTIAL IMPROVISED COVERAGE SHALL NOT EXCEED 80% IN A WATER RESOURCE DISTRICT

COMMERCIAL I
185 ATTACHMENT 7-(3) - NO MORE THAN ONE DWELLING UNIT PER 1,000 SF OF LOT AREA MAY BE PERMITTED.
DWELLING/UNIT = 1 BEDROOM
43,756/1,000 SF (UNIT) = 43
ALLOWED BY SPECIAL PERMIT - 43 UNITS
PROPOSED - 35 UNITS

PARKING REQUIREMENTS		
	REQUIRED	PROPOSED
RESIDENTIAL UNIT PARKING	53 SPACES	42 SPACES
1.5 SPACES PER UNIT (35 UNITS)		
OFFICE PARKING	2 SPACES	2 SPACES
1 SPACE PER 500 SF. (TOTAL OFFICE SPACE = 900± SF.)		
TOTAL SPACES	55 SPACES	44 SPACES

LEGEND

⊕	CATCH BASIN	☆	LIGHT POLE
⊖	DRAIN MANHOLE	⊙	UTILITY POLE
⊕	ELECTRIC MANHOLE	⤴	GUY WIRE
⊕	SEWER MANHOLE	—	SIGN
○	MANHOLE	•	WEFLAG
⊕	GAS VALVE	⊙	UTILITY POLE
⊕	GAS METER	☆	PROP. STREET LIGHTING
⊕	GAS SHUT OFF VALVE	X 0000	SPOT ELEVATION
⊕	WATER VALVE	▨	SPOT ELEVATION RIPRAP
⊕	WATER SHUT OFF VALVE		
⊕	FIRE HYDRANT		
— 000 —	EXISTING CONTOUR		
— D —	EXISTING DRAIN LINE		
— W —	EXISTING WATER LINE		
— G —	EXISTING GAS LINE		
— S —	EXISTING SEWER LINE		

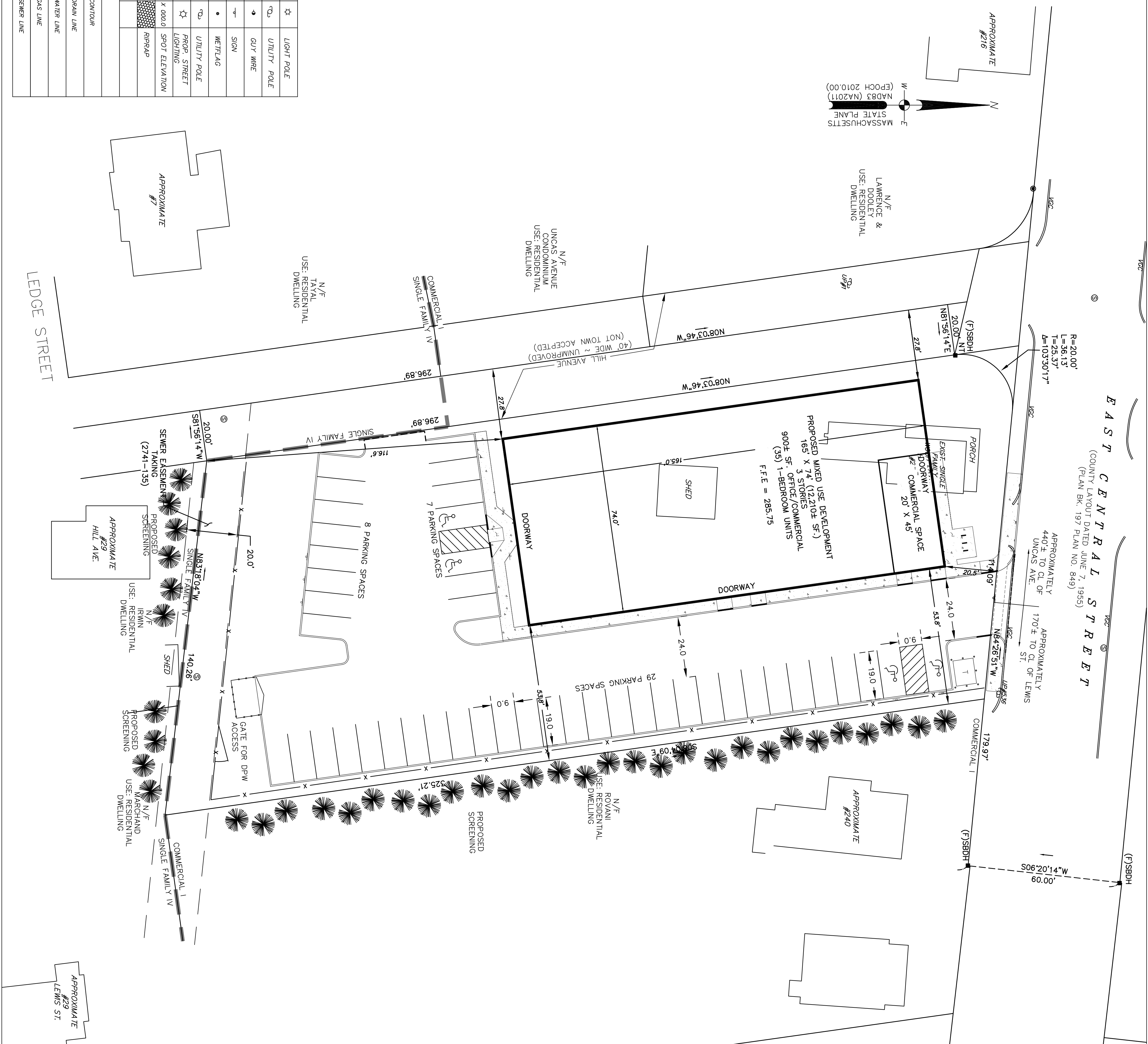
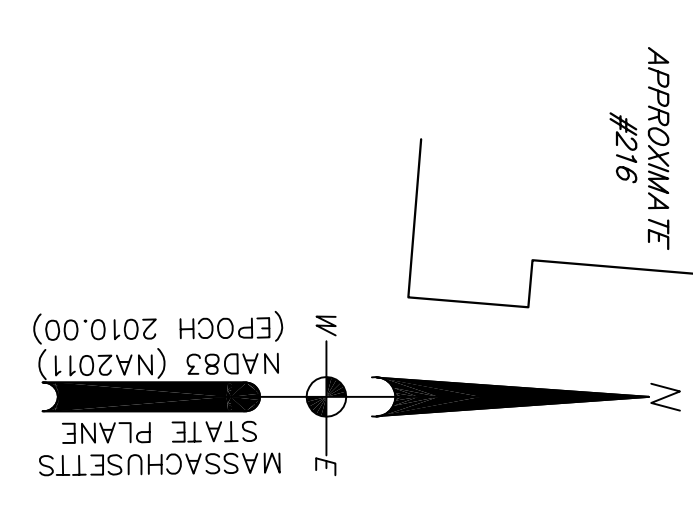

EAST CENTRAL STREET

(COUNTY LAYOUT DATED JUNE 7, 1985)
(PLAN BK. 197 PLAN NO. 849)

APPROXIMATELY 440'± TO CL OF UNCAS AVE.
APPROXIMATELY 170'± TO CL OF LEWIS ST.
APPROXIMATELY 506'± TO CL OF 60.00'

PROPOSED MIXED USE DEVELOPMENT
165' X 74' (12,210± SF.)
3 STORES/COMMERCIAL
900± SF. OFFICE/COMMERCIAL
(35) 1-BEDROOM UNITS
F.F.E = 285.75

8 PARKING SPACES

29 PARKING SPACES

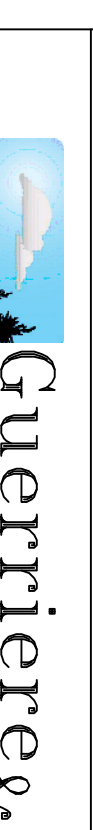

Guerriere & Halmon, Inc.
ENGINEERING & LAND SURVEYING
55 WEST CENTRAL ST. PH. (508) 528-3221
FRANKLIN, MA 02038 FX. (508) 528-7921
www.guerriereengineering.com

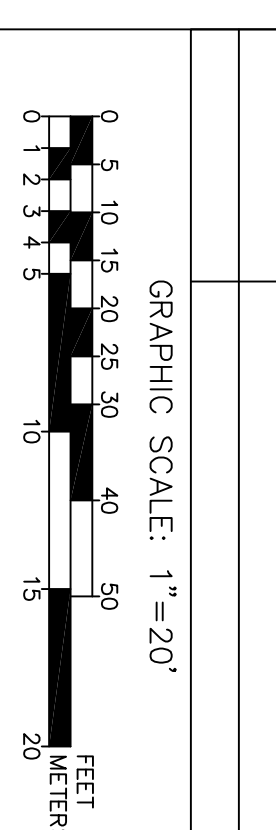

DATE	REVISION DESCRIPTION
DECEMBER 14, 2021	SITE PLAN CONCEPT 4 REVISION

**TAJ ESTATES OF FRANKLIN II
SITE PLAN & SPECIAL PERMIT
230 EAST CENTRAL STREET
FRANKLIN MASSACHUSETTS**

OWNER/APPLICANT
MOHIDDIN AHMED
95 MAIN STREET SUITE 100
WESTBOROUGH, MA. 01581

DEED BOOK 40009 PAGE 445
ASSESSORS MAP 285 LOT 069

OWNER
TAJ ESTATES OF FRANKLIN II, LLC
95 EAST MAIN STREET, SUITE 100
WESTBOROUGH, MA. 01581

LEGAL NOTES
UTILITIES ARE PLOTTED AS A COMPILATION OF RECORDED DOCUMENTS. MARKINGS AND OTHER OBSERVED EVIDENCE TO DEVELOP A VIEW OF THE UNDERGROUND UTILITIES AND SHOULD BE CONSIDERED APPROXIMATE. EXCAVATION, THE EXACT LOCATION OF UNDERGROUND FEATURES CANNOT BE DETERMINED BY COMPLETING AND VERIFYING BY RECORD DOCUMENTS OR OBSERVED PHYSICAL EVIDENCE. MA. EXIST. CONTRACTORS (IN ACCORDANCE WITH MASS.G.L. CHAPTER 82 SECTION 40 AS AMENDED) MUST CONTACT ALL UTILITY COMPANIES BEFORE EXCAVATING AND DRILLING AND CALL DISSAFE AT (888)816-SAFETZ333.

BEING A MAJORITY

APPROVED DATE:
FRANKLIN PLANNING BOARD

MANUAL TURNING MOVEMENT COUNT DATA



Accurate Counts

978-664-2565

File Name : 66410001

Site Code : 66410001

Start Date : 3/5/2020

Page No : 1

N/S Street : Chestnut St / King St

E/W Street : Route 140

City/State : Franklin, MA

Weather : Clear

Groups Printed- Cars - Trucks

Start Time	Chestnut St From North			Route 140 From East			King St From South			Route 140 From West			Int. Total
	Left	Thru	Right	Left	Thru	Right	Left	Thru	Right	Left	Thru	Right	
07:00 AM	5	51	32	37	68	7	3	84	37	19	62	4	409
07:15 AM	1	64	25	32	71	12	2	81	64	30	77	2	461
07:30 AM	1	58	15	40	65	10	6	85	53	27	86	6	452
07:45 AM	4	55	18	42	65	15	7	88	76	14	68	6	458
Total	11	228	90	151	269	44	18	338	230	90	293	18	1780
08:00 AM	6	63	25	52	60	11	1	77	60	15	73	9	452
08:15 AM	2	55	23	59	53	12	7	73	72	28	74	6	464
08:30 AM	5	59	25	41	68	12	8	75	68	15	80	9	465
08:45 AM	13	39	20	50	82	11	3	48	58	17	66	4	411
Total	26	216	93	202	263	46	19	273	258	75	293	28	1792
Grand Total	37	444	183	353	532	90	37	611	488	165	586	46	3572
Apprch %	5.6	66.9	27.6	36.2	54.6	9.2	3.3	53.8	43	20.7	73.5	5.8	
Total %	1	12.4	5.1	9.9	14.9	2.5	1	17.1	13.7	4.6	16.4	1.3	
Cars	34	436	179	348	525	88	37	603	479	160	578	46	3513
% Cars	91.9	98.2	97.8	98.6	98.7	97.8	100	98.7	98.2	97	98.6	100	98.3
Trucks	3	8	4	5	7	2	0	8	9	5	8	0	59
% Trucks	8.1	1.8	2.2	1.4	1.3	2.2	0	1.3	1.8	3	1.4	0	1.7

Start Time	Chestnut St From North				Route 140 From East				King St From South				Route 140 From West				Int. Total
	Left	Thru	Right	App. Total	Left	Thru	Right	App. Total	Left	Thru	Right	App. Total	Left	Thru	Right	App. Total	
Peak Hour Analysis From 07:00 AM to 08:45 AM - Peak 1 of 1																	
Peak Hour for Entire Intersection Begins at 07:45 AM																	
07:45 AM	4	55	18	77	42	65	15	122	7	88	76	171	14	68	6	88	458
08:00 AM	6	63	25	94	52	60	11	123	1	77	60	138	15	73	9	97	452
08:15 AM	2	55	23	80	59	53	12	124	7	73	72	152	28	74	6	108	464
08:30 AM	5	59	25	89	41	68	12	121	8	75	68	151	15	80	9	104	465
Total Volume	17	232	91	340	194	246	50	490	23	313	276	612	72	295	30	397	1839
% App. Total	5	68.2	26.8		39.6	50.2	10.2		3.8	51.1	45.1		18.1	74.3	7.6		
PHF	.708	.921	.910	.904	.822	.904	.833	.988	.719	.889	.908	.895	.643	.922	.833	.919	.989
Cars	15	227	88	330	191	241	50	482	23	307	273	603	68	290	30	388	1803
% Cars	88.2	97.8	96.7	97.1	98.5	98.0	100	98.4	100	98.1	98.9	98.5	94.4	98.3	100	97.7	98.0
Trucks	2	5	3	10	3	5	0	8	0	6	3	9	4	5	0	9	36
% Trucks	11.8	2.2	3.3	2.9	1.5	2.0	0	1.6	0	1.9	1.1	1.5	5.6	1.7	0	2.3	2.0

Accurate Counts

978-664-2565

File Name : 66410001

Site Code : 66410001

Start Date : 3/5/2020

Page No : 2

N/S Street : Chestnut St / King St

E/W Street : Route 140

City/State : Franklin, MA

Weather : Clear

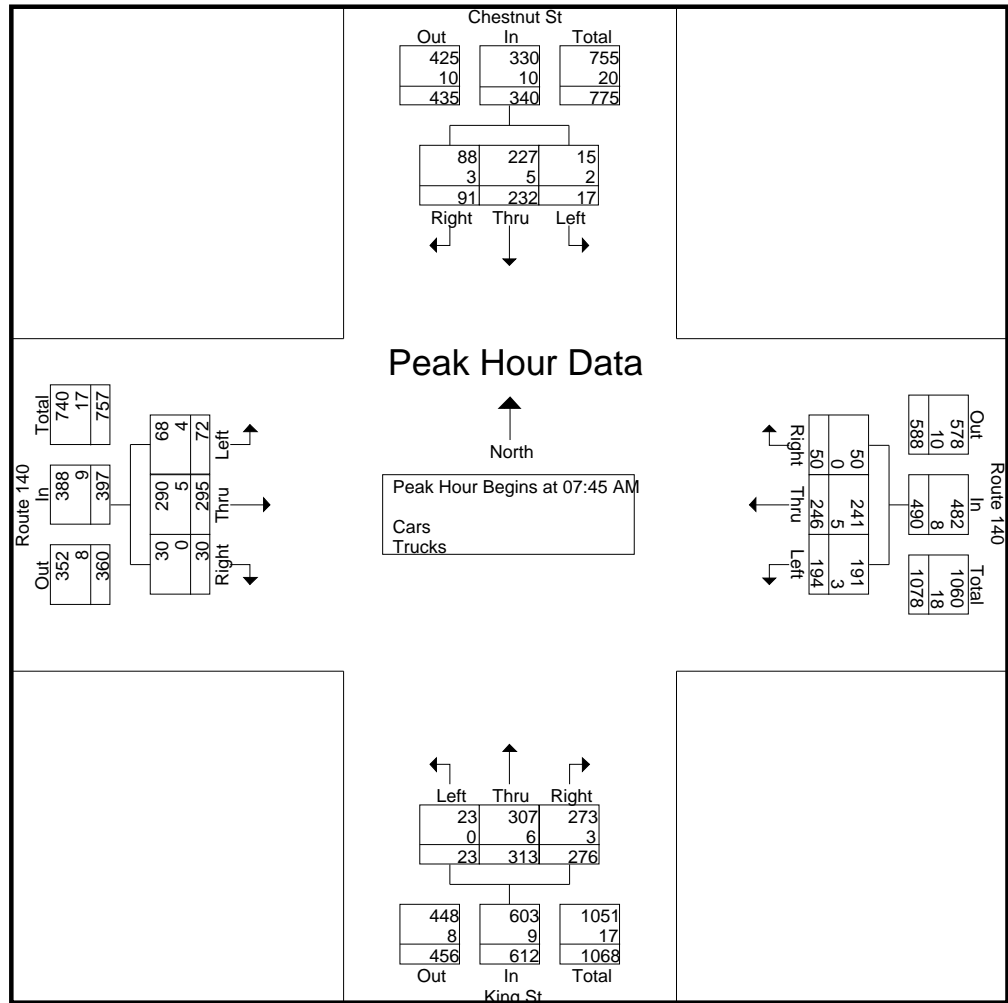

Peak Hour Analysis From 07:00 AM to 08:45 AM - Peak 1 of 1

Peak Hour for Each Approach Begins at:

	07:45 AM				08:00 AM				07:45 AM				07:15 AM			
+0 mins.	4	55	18	77	52	60	11	123	7	88	76	171	30	77	2	109
+15 mins.	6	63	25	94	59	53	12	124	1	77	60	138	27	86	6	119
+30 mins.	2	55	23	80	41	68	12	121	7	73	72	152	14	68	6	88
+45 mins.	5	59	25	89	50	82	11	143	8	75	68	151	15	73	9	97
Total Volume	17	232	91	340	202	263	46	511	23	313	276	612	86	304	23	413
% App. Total	5	68.2	26.8		39.5	51.5	9		3.8	51.1	45.1		20.8	73.6	5.6	
PHF	.708	.921	.910	.904	.856	.802	.958	.893	.719	.889	.908	.895	.717	.884	.639	.868
Cars	15	227	88	330	199	258	46	503	23	307	273	603	83	300	23	406
% Cars	88.2	97.8	96.7	97.1	98.5	98.1	100	98.4	100	98.1	98.9	98.5	96.5	98.7	100	98.3
Trucks	2	5	3	10	3	5	0	8	0	6	3	9	3	4	0	7

Accurate Counts
978-664-2565

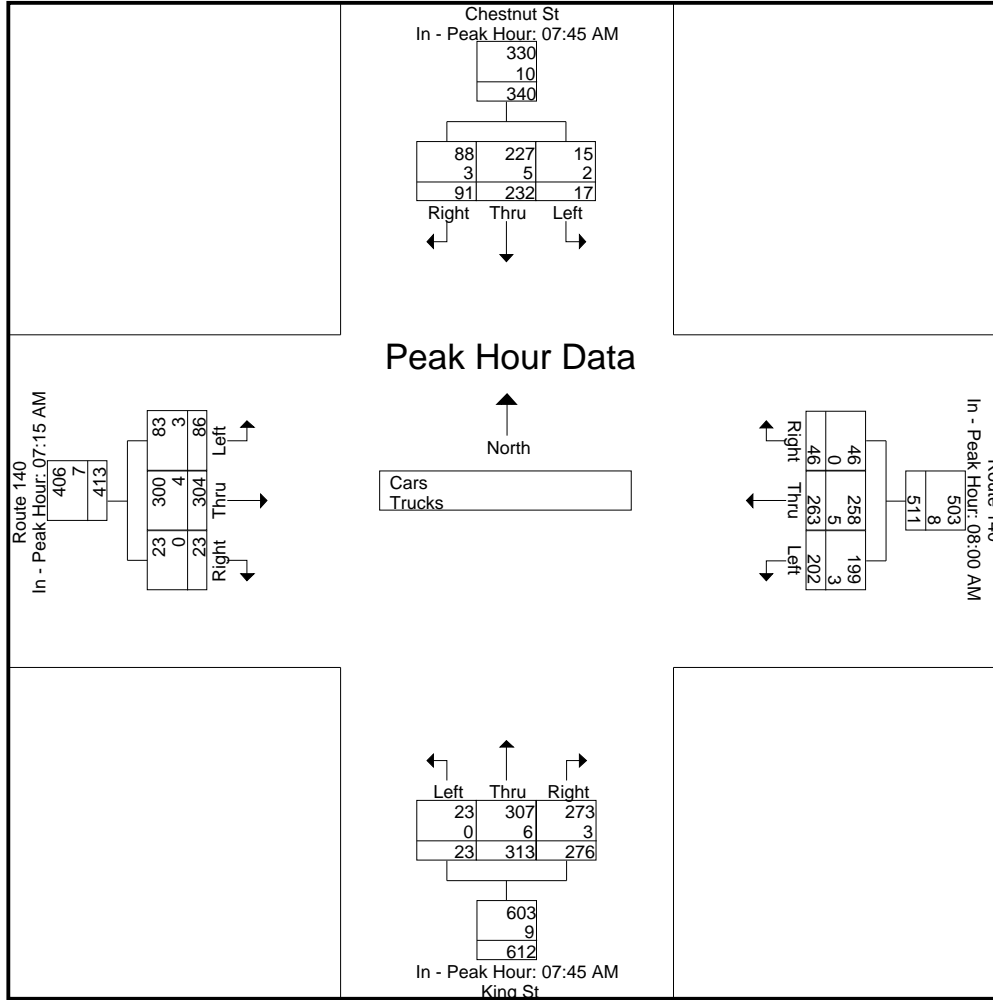

Accurate Counts

978-664-2565

File Name : 66410001

Site Code : 66410001

Start Date : 3/5/2020

Page No : 4

N/S Street : Chestnut St / King St

E/W Street : Route 140

City/State : Franklin, MA

Weather : Clear

Groups Printed- Cars

Start Time	Chestnut St From North			Route 140 From East			King St From South			Route 140 From West			Int. Total
	Left	Thru	Right	Left	Thru	Right	Left	Thru	Right	Left	Thru	Right	
07:00 AM	4	51	32	37	67	6	3	83	36	18	62	4	403
07:15 AM	1	64	25	32	71	12	2	81	59	30	75	2	454
07:30 AM	1	56	15	39	64	9	6	85	53	27	86	6	447
07:45 AM	4	55	18	41	65	15	7	88	76	12	67	6	454
Total	10	226	90	149	267	42	18	337	224	87	290	18	1758
08:00 AM	5	61	25	52	57	11	1	73	59	14	72	9	439
08:15 AM	1	55	22	58	52	12	7	71	70	27	74	6	455
08:30 AM	5	56	23	40	67	12	8	75	68	15	77	9	455
08:45 AM	13	38	19	49	82	11	3	47	58	17	65	4	406
Total	24	210	89	199	258	46	19	266	255	73	288	28	1755
Grand Total	34	436	179	348	525	88	37	603	479	160	578	46	3513
Apprch %	5.2	67.2	27.6	36.2	54.6	9.2	3.3	53.9	42.8	20.4	73.7	5.9	
Total %	1	12.4	5.1	9.9	14.9	2.5	1.1	17.2	13.6	4.6	16.5	1.3	

Start Time	Chestnut St From North				Route 140 From East				King St From South				Route 140 From West				Int. Total
	Left	Thru	Right	App. Total	Left	Thru	Right	App. Total	Left	Thru	Right	App. Total	Left	Thru	Right	App. Total	
Peak Hour Analysis From 07:00 AM to 08:45 AM - Peak 1 of 1																	
Peak Hour for Entire Intersection Begins at 07:45 AM																	
07:45 AM	4	55	18	77	41	65	15	121	7	88	76	171	12	67	6	85	454
08:00 AM	5	61	25	91	52	57	11	120	1	73	59	133	14	72	9	95	439
08:15 AM	1	55	22	78	58	52	12	122	7	71	70	148	27	74	6	107	455
08:30 AM	5	56	23	84	40	67	12	119	8	75	68	151	15	77	9	101	455
Total Volume	15	227	88	330	191	241	50	482	23	307	273	603	68	290	30	388	1803
% App. Total	4.5	68.8	26.7		39.6	50	10.4		3.8	50.9	45.3		17.5	74.7	7.7		
PHF	.750	.930	.880	.907	.823	.899	.833	.988	.719	.872	.898	.882	.630	.942	.833	.907	.991

Accurate Counts

978-664-2565

File Name : 66410001

Site Code : 66410001

Start Date : 3/5/2020

Page No : 5

N/S Street : Chestnut St / King St

E/W Street : Route 140

City/State : Franklin, MA

Weather : Clear

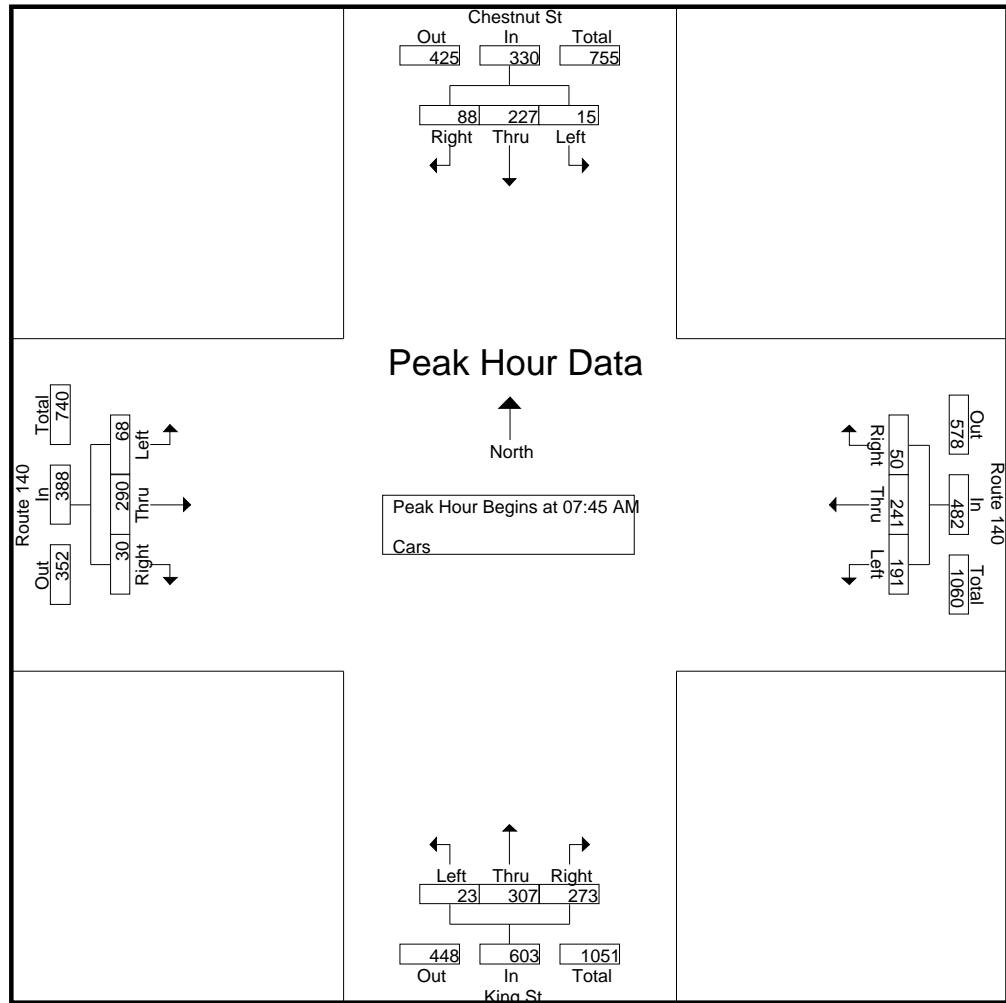

Peak Hour Analysis From 07:00 AM to 08:45 AM - Peak 1 of 1

Peak Hour for Each Approach Begins at:

	07:15 AM				08:00 AM				07:45 AM				07:15 AM			
+0 mins.	1	64	25	90	52	57	11	120	7	88	76	171	30	75	2	107
+15 mins.	1	56	15	72	58	52	12	122	1	73	59	133	27	86	6	119
+30 mins.	4	55	18	77	40	67	12	119	7	71	70	148	12	67	6	85
+45 mins.	5	61	25	91	49	82	11	142	8	75	68	151	14	72	9	95
Total Volume	11	236	83	330	199	258	46	503	23	307	273	603	83	300	23	406
% App. Total	3.3	71.5	25.2		39.6	51.3	9.1		3.8	50.9	45.3		20.4	73.9	5.7	
PHF	.550	.922	.830	.907	.858	.787	.958	.886	.719	.872	.898	.882	.692	.872	.639	.853

Accurate Counts
978-664-2565

File Name : 66410001
Site Code : 66410001
Start Date : 3/5/2020
Page No : 6

N/S Street : Chestnut St / King St
E/W Street : Route 140
City/State : Franklin, MA
Weather : Clear

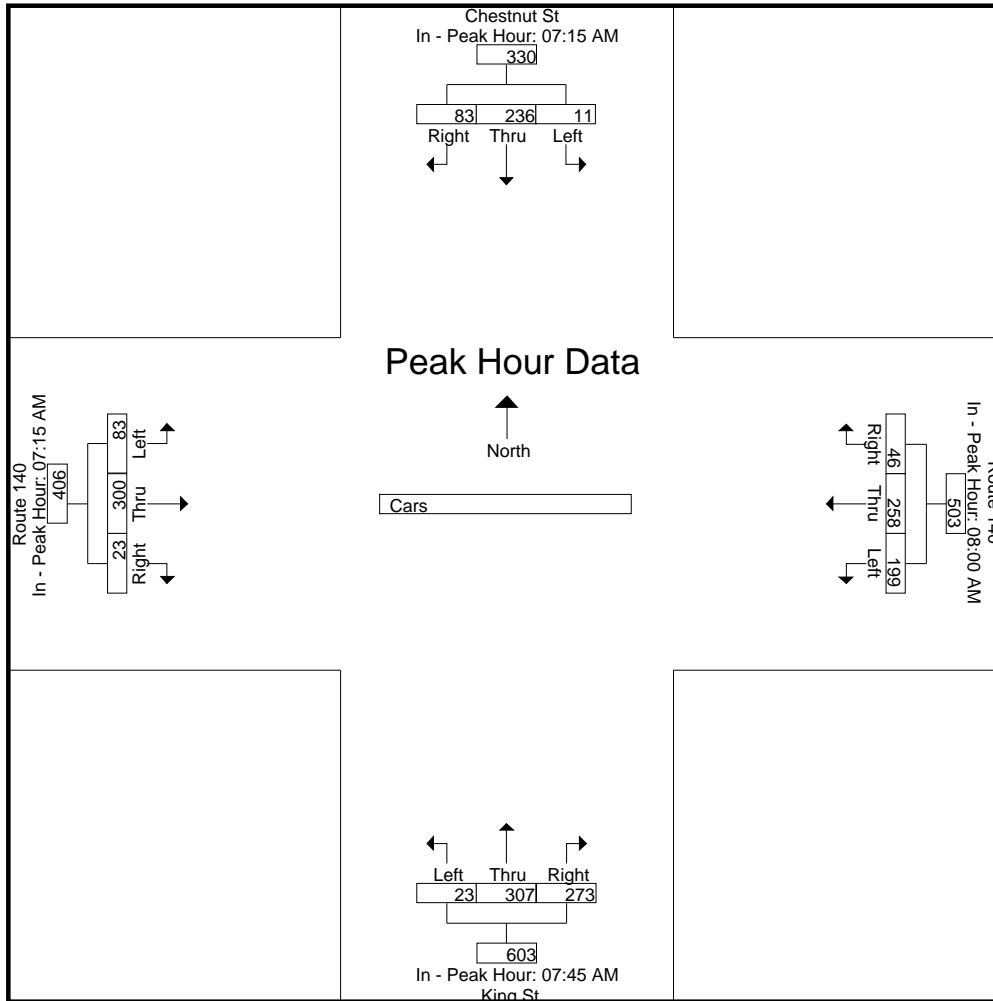

Accurate Counts

978-664-2565

File Name : 66410001

Site Code : 66410001

Start Date : 3/5/2020

Page No : 7

N/S Street : Chestnut St / King St

E/W Street : Route 140

City/State : Franklin, MA

Weather : Clear

Groups Printed- Trucks

Start Time	Chestnut St From North			Route 140 From East			King St From South			Route 140 From West			Int. Total
	Left	Thru	Right	Left	Thru	Right	Left	Thru	Right	Left	Thru	Right	
07:00 AM	1	0	0	0	1	1	0	1	1	1	0	0	6
07:15 AM	0	0	0	0	0	0	0	0	5	0	2	0	7
07:30 AM	0	2	0	1	1	1	0	0	0	0	0	0	5
07:45 AM	0	0	0	1	0	0	0	0	0	2	1	0	4
Total	1	2	0	2	2	2	0	1	6	3	3	0	22
08:00 AM	1	2	0	0	3	0	0	4	1	1	1	0	13
08:15 AM	1	0	1	1	1	0	0	2	2	1	0	0	9
08:30 AM	0	3	2	1	1	0	0	0	0	0	3	0	10
08:45 AM	0	1	1	1	0	0	0	1	0	0	1	0	5
Total	2	6	4	3	5	0	0	7	3	2	5	0	37
Grand Total	3	8	4	5	7	2	0	8	9	5	8	0	59
Apprch %	20	53.3	26.7	35.7	50	14.3	0	47.1	52.9	38.5	61.5	0	
Total %	5.1	13.6	6.8	8.5	11.9	3.4	0	13.6	15.3	8.5	13.6	0	

Start Time	Chestnut St From North				Route 140 From East				King St From South				Route 140 From West				Int. Total
	Left	Thru	Right	App. Total	Left	Thru	Right	App. Total	Left	Thru	Right	App. Total	Left	Thru	Right	App. Total	
Peak Hour Analysis From 07:00 AM to 08:45 AM - Peak 1 of 1																	
Peak Hour for Entire Intersection Begins at 08:00 AM																	
08:00 AM	1	2	0	3	0	3	0	3	0	4	1	5	1	1	0	2	13
08:15 AM	1	0	1	2	1	1	0	2	0	2	2	4	1	0	0	1	9
08:30 AM	0	3	2	5	1	1	0	2	0	0	0	0	0	3	0	3	10
08:45 AM	0	1	1	2	1	0	0	1	0	1	0	1	0	1	0	1	5
Total Volume	2	6	4	12	3	5	0	8	0	7	3	10	2	5	0	7	37
% App. Total	16.7	50	33.3		37.5	62.5	0		0	70	30		28.6	71.4	0		
PHF	.500	.500	.500	.600	.750	.417	.000	.667	.000	.438	.375	.500	.500	.417	.000	.583	.712

Accurate Counts

978-664-2565

File Name : 66410001

Site Code : 66410001

Start Date : 3/5/2020

Page No : 8

N/S Street : Chestnut St / King St

E/W Street : Route 140

City/State : Franklin, MA

Weather : Clear

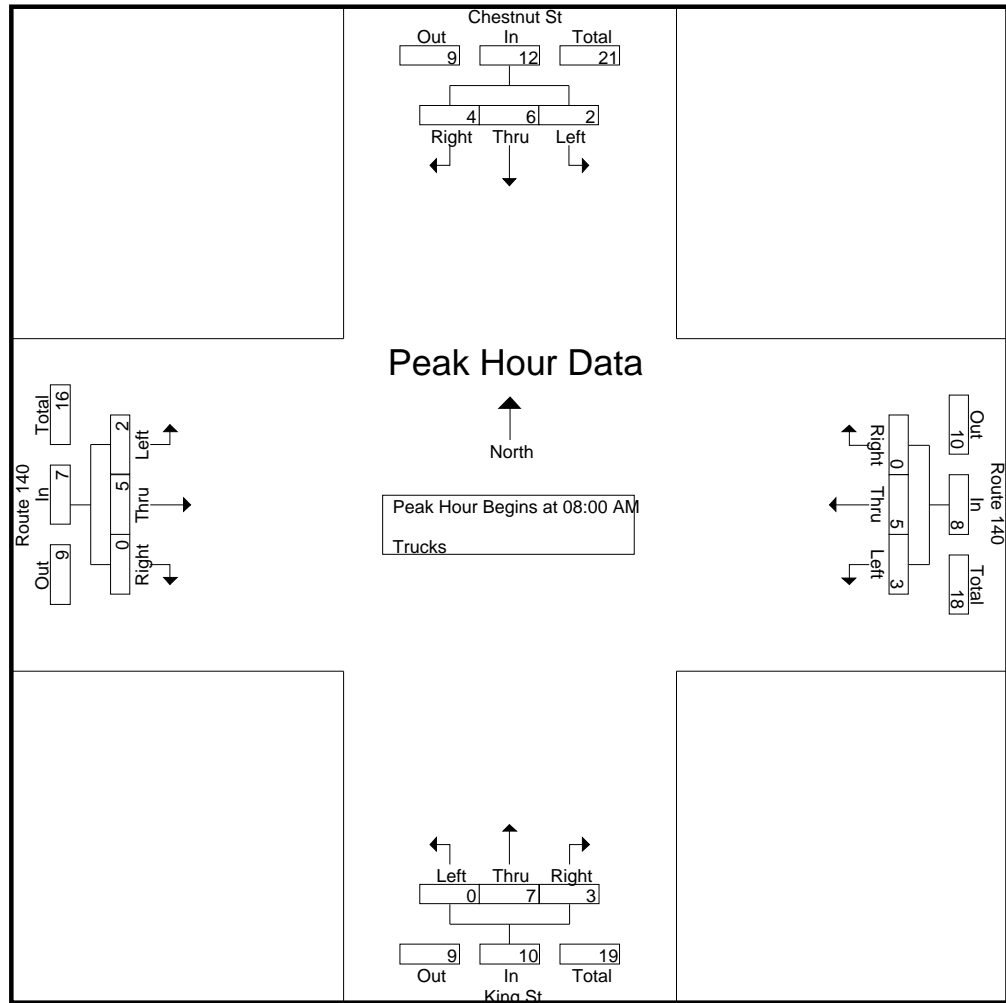

Peak Hour Analysis From 07:00 AM to 08:45 AM - Peak 1 of 1

Peak Hour for Each Approach Begins at:

	08:00 AM				07:30 AM				07:15 AM				07:45 AM			
+0 mins.	1	2	0	3	1	1	1	3	0	0	5	5	2	1	0	3
+15 mins.	1	0	1	2	1	0	0	1	0	0	0	0	1	1	0	2
+30 mins.	0	3	2	5	0	3	0	3	0	0	0	0	1	0	0	1
+45 mins.	0	1	1	2	1	1	0	2	0	4	1	5	0	3	0	3
Total Volume	2	6	4	12	3	5	1	9	0	4	6	10	4	5	0	9
% App. Total	16.7	50	33.3		33.3	55.6	11.1		0	40	60		44.4	55.6	0	
PHF	.500	.500	.500	.600	.750	.417	.250	.750	.000	.250	.300	.500	.500	.417	.000	.750

Accurate Counts
978-664-2565

File Name : 66410001
Site Code : 66410001
Start Date : 3/5/2020
Page No : 9

N/S Street : Chestnut St / King St
E/W Street : Route 140
City/State : Franklin, MA
Weather : Clear

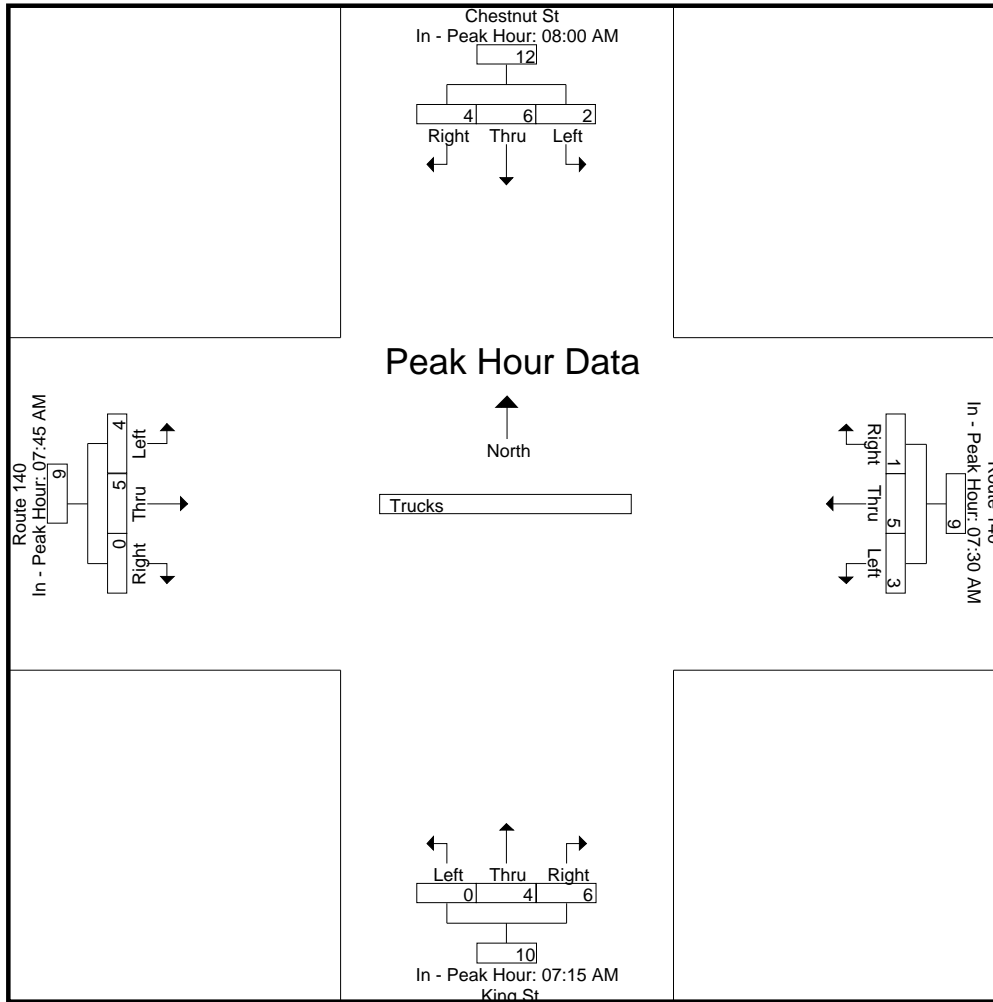

Accurate Counts

978-664-2565

File Name : 66410001

Site Code : 66410001

Start Date : 3/5/2020

Page No : 10

N/S Street : Chestnut St / King St

E/W Street : Route 140

City/State : Franklin, MA

Weather : Clear

Groups Printed- Bikes Peds

Start Time	Chestnut St From North				Route 140 From East				King St From South				Route 140 From West				Exclu. Total	Inclu. Total	Int. Total
	Left	Thru	Right	Peds	Left	Thru	Right	Peds	Left	Thru	Right	Peds	Left	Thru	Right	Peds			
07:00 AM	0	0	0	1	0	0	0	0	0	0	0	0	0	0	0	0	1	0	1
07:15 AM	0	0	0	0	0	0	0	0	0	0	0	0	0	0	0	0	0	0	0
07:30 AM	0	0	0	1	0	1	0	0	0	0	0	1	0	0	0	1	3	1	4
07:45 AM	0	0	0	1	0	0	0	0	0	0	0	1	0	0	0	0	2	0	2
Total	0	0	0	3	0	1	0	0	0	0	0	2	0	0	0	1	6	1	7
08:00 AM	0	0	0	0	0	0	0	0	0	0	0	0	0	0	0	0	0	0	0
08:15 AM	0	0	0	3	0	0	0	0	0	0	0	0	0	0	0	0	3	0	3
08:30 AM	0	0	0	1	0	0	0	0	0	0	0	0	0	0	0	0	1	0	1
08:45 AM	0	0	0	0	0	0	0	0	0	0	0	0	0	0	0	0	0	0	0
Total	0	0	0	4	0	0	0	0	0	0	0	0	0	0	0	0	4	0	4
Grand Total	0	0	0	7	0	1	0	0	0	0	0	2	0	0	0	1	10	1	11
Apprch %	0	0	0		0	100	0		0	0	0		0	0	0				
Total %	0	0	0		0	100	0		0	0	0		0	0	0		90.9	9.1	

Start Time	Chestnut St From North				Route 140 From East				King St From South				Route 140 From West				Int. Total	
	Left	Thru	Right	App. Total	Left	Thru	Right	App. Total	Left	Thru	Right	App. Total	Left	Thru	Right	App. Total		
Peak Hour Analysis From 07:00 AM to 08:45 AM - Peak 1 of 1																		
Peak Hour for Entire Intersection Begins at 07:00 AM																		
07:00 AM	0	0	0	0	0	0	0	0	0	0	0	0	0	0	0	0	0	0
07:15 AM	0	0	0	0	0	0	0	0	0	0	0	0	0	0	0	0	0	0
07:30 AM	0	0	0	0	0	1	0	1	0	0	0	0	0	0	0	0	0	1
07:45 AM	0	0	0	0	0	0	0	0	0	0	0	0	0	0	0	0	0	0
Total Volume	0	0	0	0	0	1	0	1	0	0	0	0	0	0	0	0	0	1
% App. Total	0	0	0		0	100	0		0	0	0		0	0	0			
PHF	.000	.000	.000	.000	.000	.250	.000	.250	.000	.000	.000	.000	.000	.000	.000	.000	.000	.250

Accurate Counts
978-664-2565

File Name : 66410001
Site Code : 66410001
Start Date : 3/5/2020
Page No : 11

N/S Street : Chestnut St / King St
E/W Street : Route 140
City/State : Franklin, MA
Weather : Clear

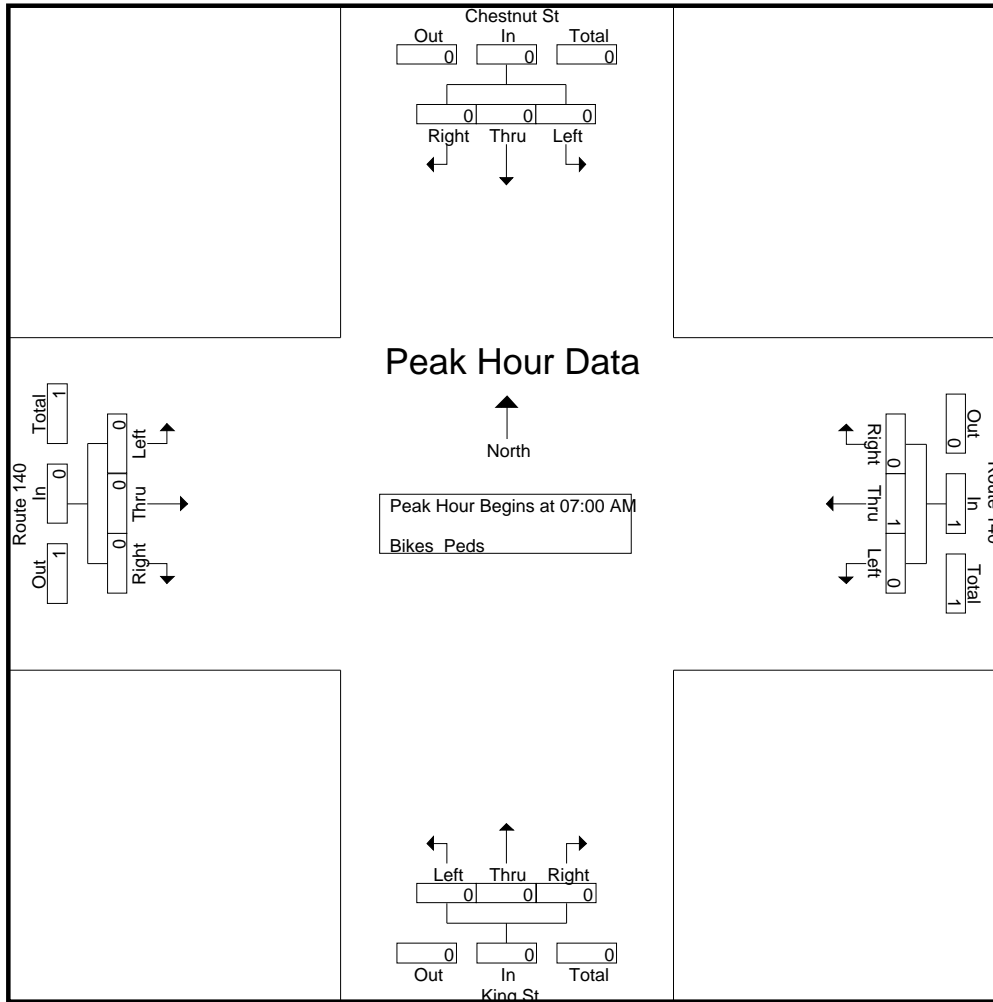

Peak Hour Analysis From 07:00 AM to 08:45 AM - Peak 1 of 1
Peak Hour for Each Approach Begins at:

	07:00 AM				07:00 AM				07:00 AM				07:00 AM			
+0 mins.	0	0	0	0	0	0	0	0	0	0	0	0	0	0	0	0
+15 mins.	0	0	0	0	0	0	0	0	0	0	0	0	0	0	0	0
+30 mins.	0	0	0	0	0	1	0	1	0	0	0	0	0	0	0	0
+45 mins.	0	0	0	0	0	0	0	0	0	0	0	0	0	0	0	0
Total Volume	0	0	0	0	0	1	0	1	0	0	0	0	0	0	0	0
% App. Total	0	0	0	0	0	100	0	0	0	0	0	0	0	0	0	0
PHF	.000	.000	.000	.000	.000	.250	.000	.250	.000	.000	.000	.000	.000	.000	.000	.000

Accurate Counts
978-664-2565

File Name : 66410001
Site Code : 66410001
Start Date : 3/5/2020
Page No : 12

N/S Street : Chestnut St / King St
E/W Street : Route 140
City/State : Franklin, MA
Weather : Clear

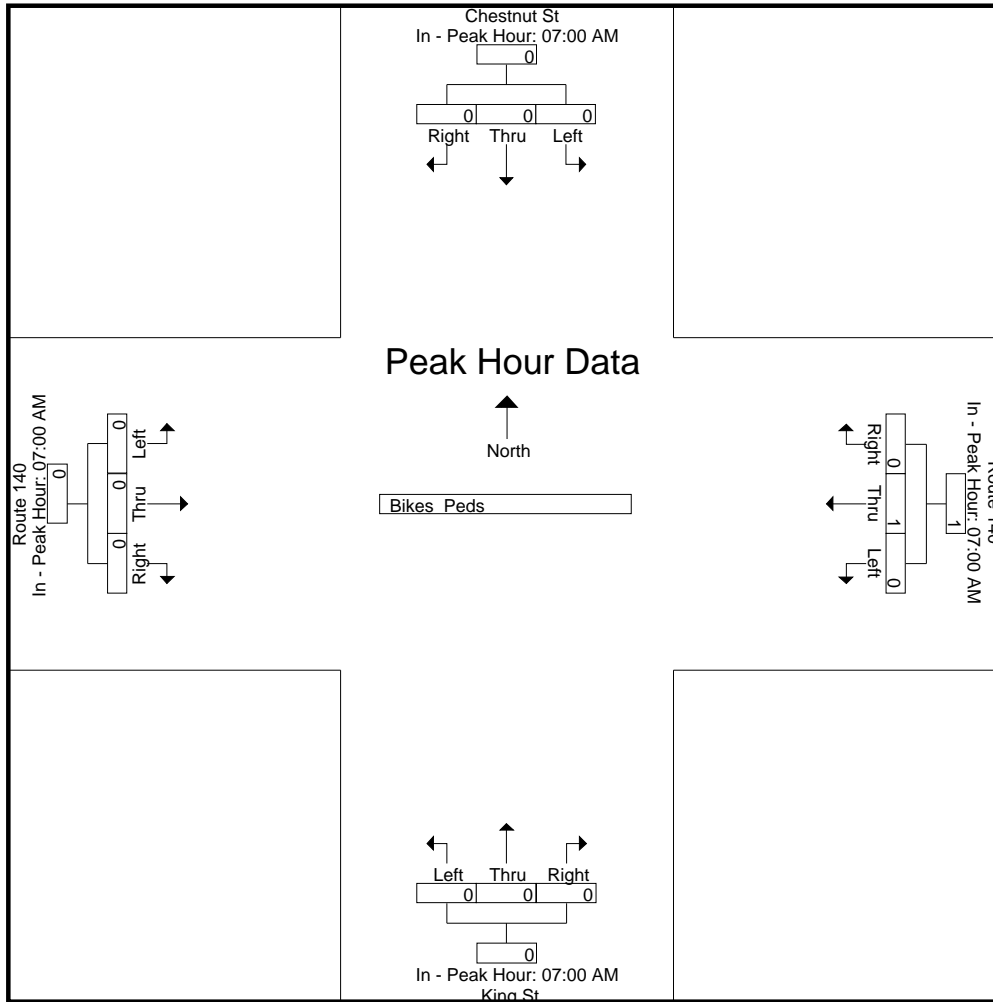

Accurate Counts

978-664-2565

N/S Street : Chestnut St / King St
 E/W Street : Route 140
 City/State : Franklin, MA
 Weather : Clear

File Name : 66410001
 Site Code : 66410001
 Start Date : 3/5/2020
 Page No : 1

Groups Printed- Cars - Trucks

Start Time	Chestnut St From North			Route 140 From East			King St From South			Route 140 From West			Int. Total
	Left	Thru	Right	Left	Thru	Right	Left	Thru	Right	Left	Thru	Right	
04:00 PM	8	74	14	78	100	9	4	49	54	29	98	10	527
04:15 PM	6	87	26	72	124	11	3	62	68	24	66	10	559
04:30 PM	5	83	25	78	110	10	5	53	56	32	105	11	573
04:45 PM	5	71	23	72	107	15	12	60	64	28	79	6	542
Total	24	315	88	300	441	45	24	224	242	113	348	37	2201
05:00 PM	7	49	20	83	109	8	8	64	83	31	102	3	567
05:15 PM	4	94	32	99	99	11	6	52	62	27	94	9	589
05:30 PM	7	75	31	81	99	12	11	75	67	42	86	17	603
05:45 PM	7	69	27	70	93	12	3	67	64	39	103	9	563
Total	25	287	110	333	400	43	28	258	276	139	385	38	2322
Grand Total	49	602	198	633	841	88	52	482	518	252	733	75	4523
Apprch %	5.8	70.9	23.3	40.5	53.8	5.6	4.9	45.8	49.2	23.8	69.2	7.1	
Total %	1.1	13.3	4.4	14	18.6	1.9	1.1	10.7	11.5	5.6	16.2	1.7	
Cars	49	598	197	631	840	88	51	477	516	251	730	75	4503
% Cars	100	99.3	99.5	99.7	99.9	100	98.1	99	99.6	99.6	99.6	100	99.6
Trucks	0	4	1	2	1	0	1	5	2	1	3	0	20
% Trucks	0	0.7	0.5	0.3	0.1	0	1.9	1	0.4	0.4	0.4	0	0.4

Start Time	Chestnut St From North				Route 140 From East				King St From South				Route 140 From West				Int. Total
	Left	Thru	Right	App. Total	Left	Thru	Right	App. Total	Left	Thru	Right	App. Total	Left	Thru	Right	App. Total	
Peak Hour Analysis From 04:00 PM to 05:45 PM - Peak 1 of 1																	
Peak Hour for Entire Intersection Begins at 05:00 PM																	
05:00 PM	7	49	20	76	83	109	8	200	8	64	83	155	31	102	3	136	567
05:15 PM	4	94	32	130	99	99	11	209	6	52	62	120	27	94	9	130	589
05:30 PM	7	75	31	113	81	99	12	192	11	75	67	153	42	86	17	145	603
05:45 PM	7	69	27	103	70	93	12	175	3	67	64	134	39	103	9	151	563
Total Volume	25	287	110	422	333	400	43	776	28	258	276	562	139	385	38	562	2322
% App. Total	5.9	68	26.1		42.9	51.5	5.5		5	45.9	49.1		24.7	68.5	6.8		
PHF	.893	.763	.859	.812	.841	.917	.896	.928	.636	.860	.831	.906	.827	.934	.559	.930	.963
Cars	25	285	110	420	332	400	43	775	27	256	274	557	139	384	38	561	2313
% Cars	100	99.3	100	99.5	99.7	100	100	99.9	96.4	99.2	99.3	99.1	100	99.7	100	99.8	99.6
Trucks	0	2	0	2	1	0	0	1	1	2	2	5	0	1	0	1	9
% Trucks	0	0.7	0	0.5	0.3	0	0	0.1	3.6	0.8	0.7	0.9	0	0.3	0	0.2	0.4

Accurate Counts

978-664-2565

File Name : 66410001

Site Code : 66410001

Start Date : 3/5/2020

Page No : 2

N/S Street : Chestnut St / King St

E/W Street : Route 140

City/State : Franklin, MA

Weather : Clear

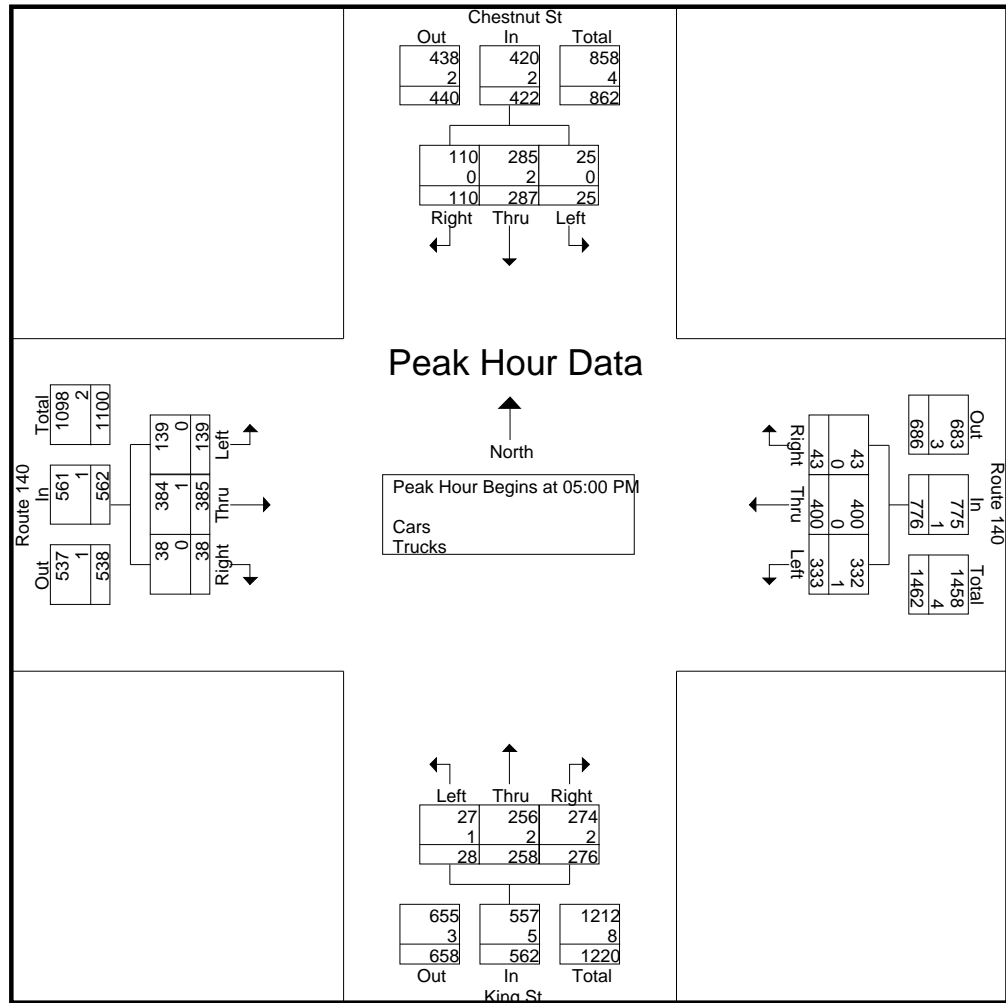

Peak Hour Analysis From 04:00 PM to 05:45 PM - Peak 1 of 1

Peak Hour for Each Approach Begins at:

	04:00 PM				04:30 PM				04:45 PM				05:00 PM			
+0 mins.	8	74	14	96	78	110	10	198	12	60	64	136	31	102	3	136
+15 mins.	6	87	26	119	72	107	15	194	8	64	83	155	27	94	9	130
+30 mins.	5	83	25	113	83	109	8	200	6	52	62	120	42	86	17	145
+45 mins.	5	71	23	99	99	99	11	209	11	75	67	153	39	103	9	151
Total Volume	24	315	88	427	332	425	44	801	37	251	276	564	139	385	38	562
% App. Total	5.6	73.8	20.6		41.4	53.1	5.5		6.6	44.5	48.9		24.7	68.5	6.8	
PHF	.750	.905	.846	.897	.838	.966	.733	.958	.771	.837	.831	.910	.827	.934	.559	.930
Cars	24	313	87	424	331	425	44	800	36	250	274	560	139	384	38	561
% Cars	100	99.4	98.9	99.3	99.7	100	100	99.9	97.3	99.6	99.3	99.3	100	99.7	100	99.8
Trucks	0	2	1	3	1	0	0	1	1	1	2	4	0	1	0	1

Accurate Counts
978-664-2565

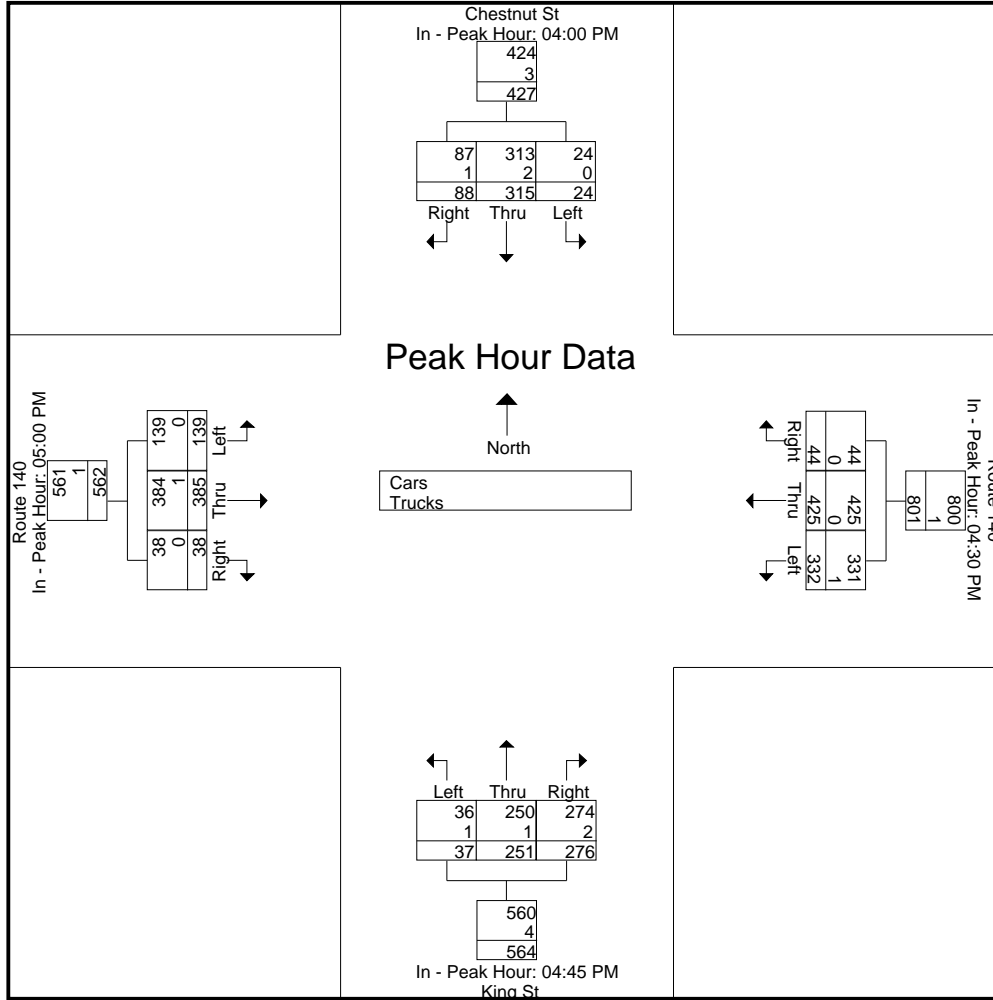

Accurate Counts

978-664-2565

File Name : 66410001

Site Code : 66410001

Start Date : 3/5/2020

Page No : 4

N/S Street : Chestnut St / King St

E/W Street : Route 140

City/State : Franklin, MA

Weather : Clear

Groups Printed- Cars

Start Time	Chestnut St From North			Route 140 From East			King St From South			Route 140 From West			Int. Total
	Left	Thru	Right	Left	Thru	Right	Left	Thru	Right	Left	Thru	Right	
04:00 PM	8	73	13	78	100	9	4	48	54	29	98	10	524
04:15 PM	6	87	26	72	123	11	3	61	68	23	65	10	555
04:30 PM	5	82	25	77	110	10	5	52	56	32	105	11	570
04:45 PM	5	71	23	72	107	15	12	60	64	28	78	6	541
Total	24	313	87	299	440	45	24	221	242	112	346	37	2190
05:00 PM	7	48	20	83	109	8	7	64	81	31	102	3	563
05:15 PM	4	94	32	99	99	11	6	51	62	27	94	9	588
05:30 PM	7	74	31	80	99	12	11	75	67	42	86	17	601
05:45 PM	7	69	27	70	93	12	3	66	64	39	102	9	561
Total	25	285	110	332	400	43	27	256	274	139	384	38	2313
Grand Total	49	598	197	631	840	88	51	477	516	251	730	75	4503
Apprch %	5.8	70.9	23.3	40.5	53.9	5.6	4.9	45.7	49.4	23.8	69.1	7.1	
Total %	1.1	13.3	4.4	14	18.7	2	1.1	10.6	11.5	5.6	16.2	1.7	

Start Time	Chestnut St From North				Route 140 From East				King St From South				Route 140 From West				Int. Total
	Left	Thru	Right	App. Total	Left	Thru	Right	App. Total	Left	Thru	Right	App. Total	Left	Thru	Right	App. Total	
Peak Hour Analysis From 04:00 PM to 05:45 PM - Peak 1 of 1																	
Peak Hour for Entire Intersection Begins at 05:00 PM																	
05:00 PM	7	48	20	75	83	109	8	200	7	64	81	152	31	102	3	136	563
05:15 PM	4	94	32	130	99	99	11	209	6	51	62	119	27	94	9	130	588
05:30 PM	7	74	31	112	80	99	12	191	11	75	67	153	42	86	17	145	601
05:45 PM	7	69	27	103	70	93	12	175	3	66	64	133	39	102	9	150	561
Total Volume	25	285	110	420	332	400	43	775	27	256	274	557	139	384	38	561	2313
% App. Total	6	67.9	26.2		42.8	51.6	5.5		4.8	46	49.2		24.8	68.4	6.8		
PHF	.893	.758	.859	.808	.838	.917	.896	.927	.614	.853	.846	.910	.827	.941	.559	.935	.962

Accurate Counts
978-664-2565

File Name : 66410001
Site Code : 66410001
Start Date : 3/5/2020
Page No : 5

N/S Street : Chestnut St / King St
E/W Street : Route 140
City/State : Franklin, MA
Weather : Clear

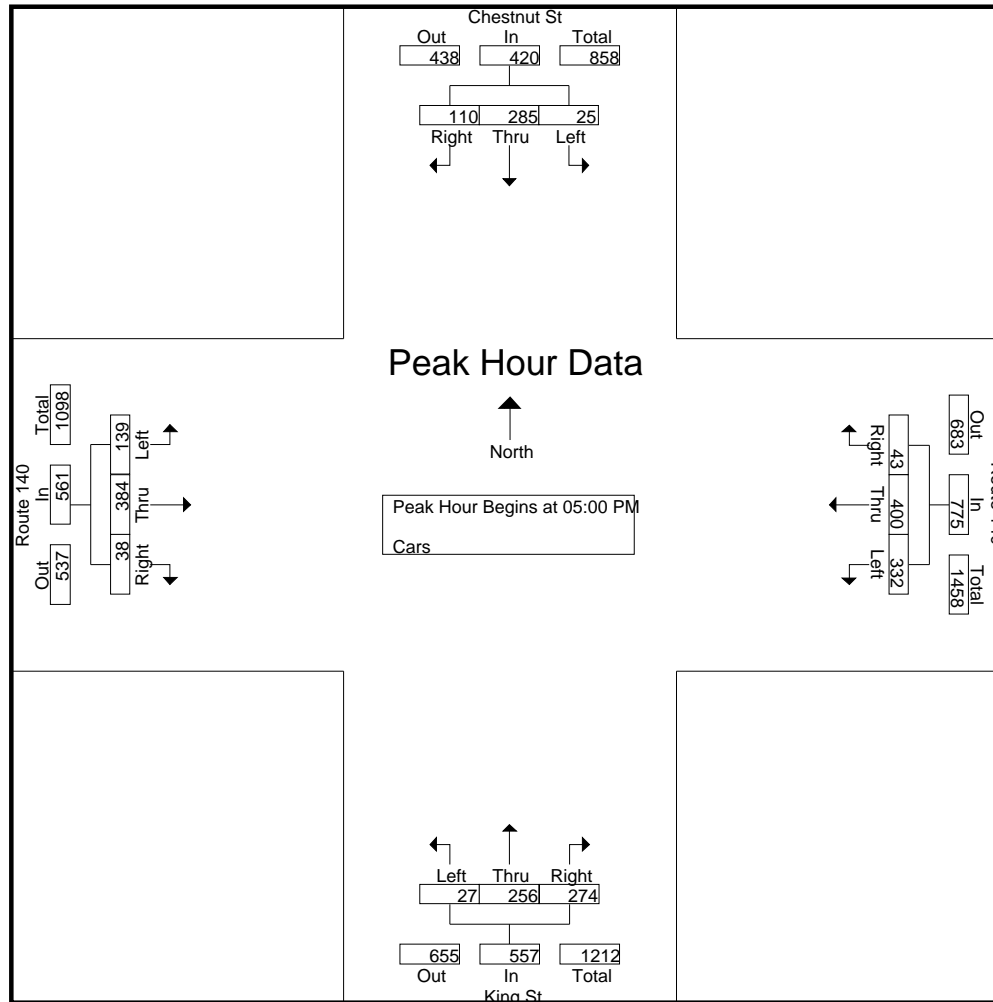

Peak Hour Analysis From 04:00 PM to 05:45 PM - Peak 1 of 1
Peak Hour for Each Approach Begins at:

	04:00 PM				04:30 PM				04:45 PM				05:00 PM			
+0 mins.	8	73	13	94	77	110	10	197	12	60	64	136	31	102	3	136
+15 mins.	6	87	26	119	72	107	15	194	7	64	81	152	27	94	9	130
+30 mins.	5	82	25	112	83	109	8	200	6	51	62	119	42	86	17	145
+45 mins.	5	71	23	99	99	99	11	209	11	75	67	153	39	102	9	150
Total Volume	24	313	87	424	331	425	44	800	36	250	274	560	139	384	38	561
% App. Total	5.7	73.8	20.5		41.4	53.1	5.5		6.4	44.6	48.9		24.8	68.4	6.8	
PHF	.750	.899	.837	.891	.836	.966	.733	.957	.750	.833	.846	.915	.827	.941	.559	.935

Accurate Counts
978-664-2565

File Name : 66410001
Site Code : 66410001
Start Date : 3/5/2020
Page No : 6

N/S Street : Chestnut St / King St
E/W Street : Route 140
City/State : Franklin, MA
Weather : Clear

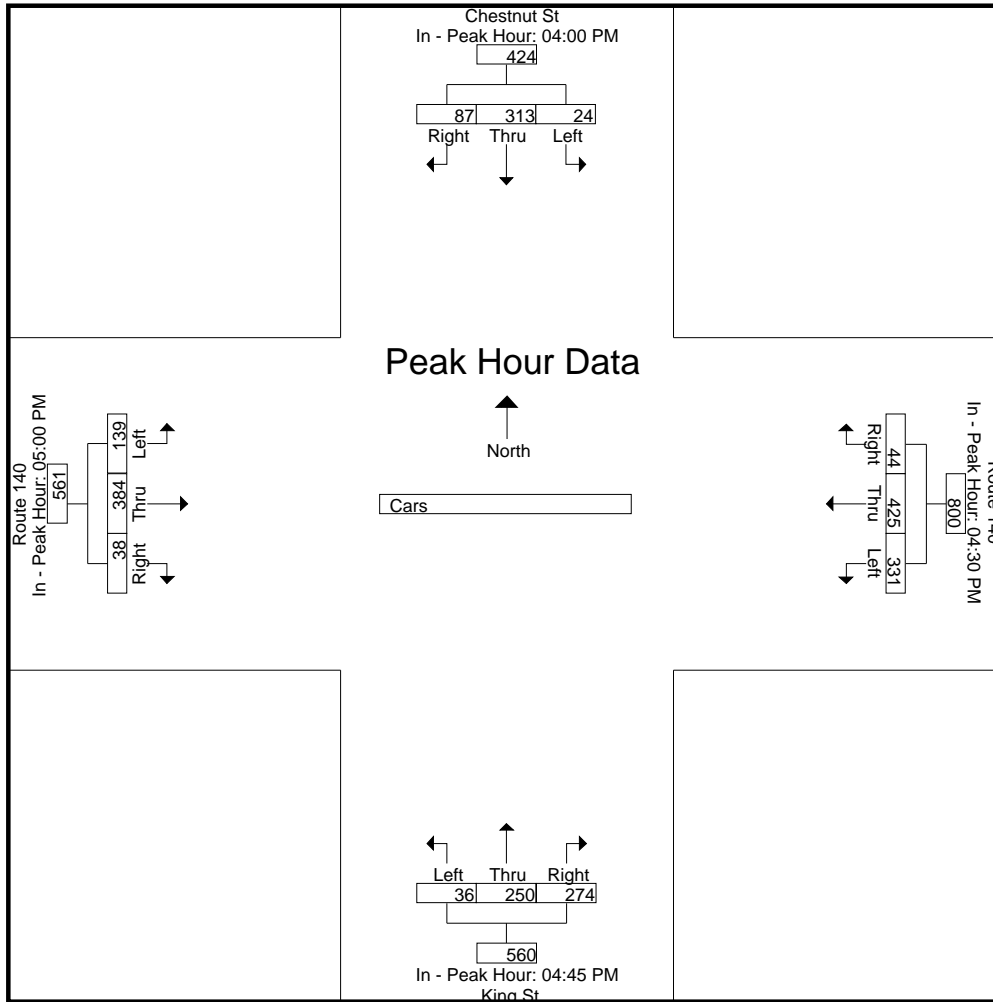

Accurate Counts

978-664-2565

File Name : 66410001

Site Code : 66410001

Start Date : 3/5/2020

Page No : 7

N/S Street : Chestnut St / King St

E/W Street : Route 140

City/State : Franklin, MA

Weather : Clear

Groups Printed- Trucks

Start Time	Chestnut St From North			Route 140 From East			King St From South			Route 140 From West			Int. Total
	Left	Thru	Right	Left	Thru	Right	Left	Thru	Right	Left	Thru	Right	
04:00 PM	0	1	1	0	0	0	0	1	0	0	0	0	3
04:15 PM	0	0	0	0	1	0	0	1	0	1	1	0	4
04:30 PM	0	1	0	1	0	0	0	1	0	0	0	0	3
04:45 PM	0	0	0	0	0	0	0	0	0	0	1	0	1
Total	0	2	1	1	1	0	0	3	0	1	2	0	11
05:00 PM	0	1	0	0	0	0	1	0	2	0	0	0	4
05:15 PM	0	0	0	0	0	0	0	1	0	0	0	0	1
05:30 PM	0	1	0	1	0	0	0	0	0	0	0	0	2
05:45 PM	0	0	0	0	0	0	0	1	0	0	1	0	2
Total	0	2	0	1	0	0	1	2	2	0	1	0	9
Grand Total	0	4	1	2	1	0	1	5	2	1	3	0	20
Apprch %	0	80	20	66.7	33.3	0	12.5	62.5	25	25	75	0	
Total %	0	20	5	10	5	0	5	25	10	5	15	0	

Start Time	Chestnut St From North				Route 140 From East				King St From South				Route 140 From West				Int. Total
	Left	Thru	Right	App. Total	Left	Thru	Right	App. Total	Left	Thru	Right	App. Total	Left	Thru	Right	App. Total	
Peak Hour Analysis From 04:00 PM to 05:45 PM - Peak 1 of 1																	
Peak Hour for Entire Intersection Begins at 04:15 PM																	
04:15 PM	0	0	0	0	0	1	0	1	0	1	0	1	1	1	0	2	4
04:30 PM	0	1	0	1	1	0	0	1	0	1	0	1	0	0	0	0	3
04:45 PM	0	0	0	0	0	0	0	0	0	0	0	0	0	1	0	1	1
05:00 PM	0	1	0	1	0	0	0	0	1	0	2	3	0	0	0	0	4
Total Volume	0	2	0	2	1	1	0	2	1	2	2	5	1	2	0	3	12
% App. Total	0	100	0	0	50	50	0	0	20	40	40	0	33.3	66.7	0	0	0
PHF	.000	.500	.000	.500	.250	.250	.000	.500	.250	.500	.250	.417	.250	.500	.000	.375	.750

Accurate Counts
978-664-2565

File Name : 66410001
Site Code : 66410001
Start Date : 3/5/2020
Page No : 8

N/S Street : Chestnut St / King St
E/W Street : Route 140
City/State : Franklin, MA
Weather : Clear

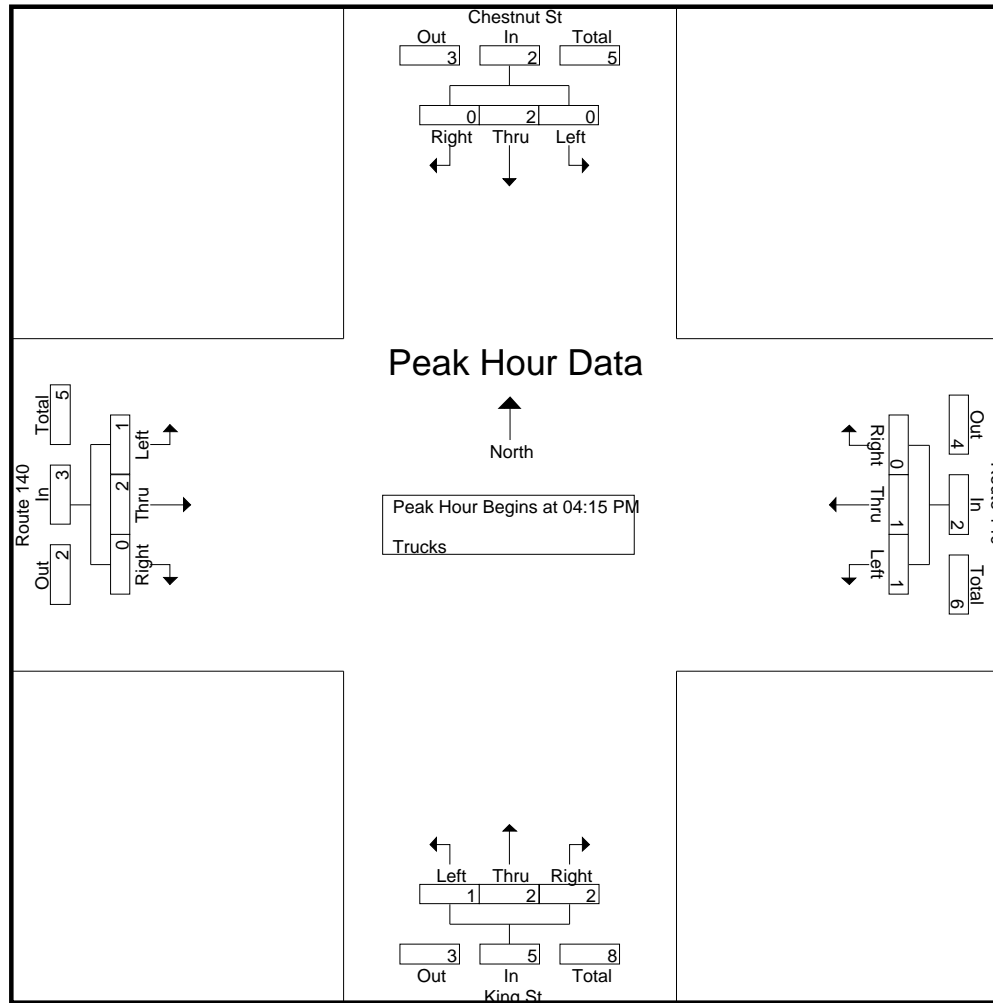

Peak Hour Analysis From 04:00 PM to 05:45 PM - Peak 1 of 1
Peak Hour for Each Approach Begins at:

	04:00 PM				04:15 PM				04:00 PM							
+0 mins.	0	1	1	2	0	0	0	0	0	1	0	1	0	0	0	0
+15 mins.	0	0	0	0	0	1	0	1	0	1	0	1	1	1	0	2
+30 mins.	0	1	0	1	1	0	0	1	0	0	0	0	0	0	0	0
+45 mins.	0	0	0	0	0	0	0	0	1	0	2	3	0	1	0	1
Total Volume	0	2	1	3	1	1	0	2	1	2	2	5	1	2	0	3
% App. Total	0	66.7	33.3		50	50	0		20	40	40		33.3	66.7	0	
PHF	.000	.500	.250	.375	.250	.250	.000	.500	.250	.500	.250	.417	.250	.500	.000	.375

Accurate Counts
978-664-2565

File Name : 66410001
Site Code : 66410001
Start Date : 3/5/2020
Page No : 9

N/S Street : Chestnut St / King St
E/W Street : Route 140
City/State : Franklin, MA
Weather : Clear

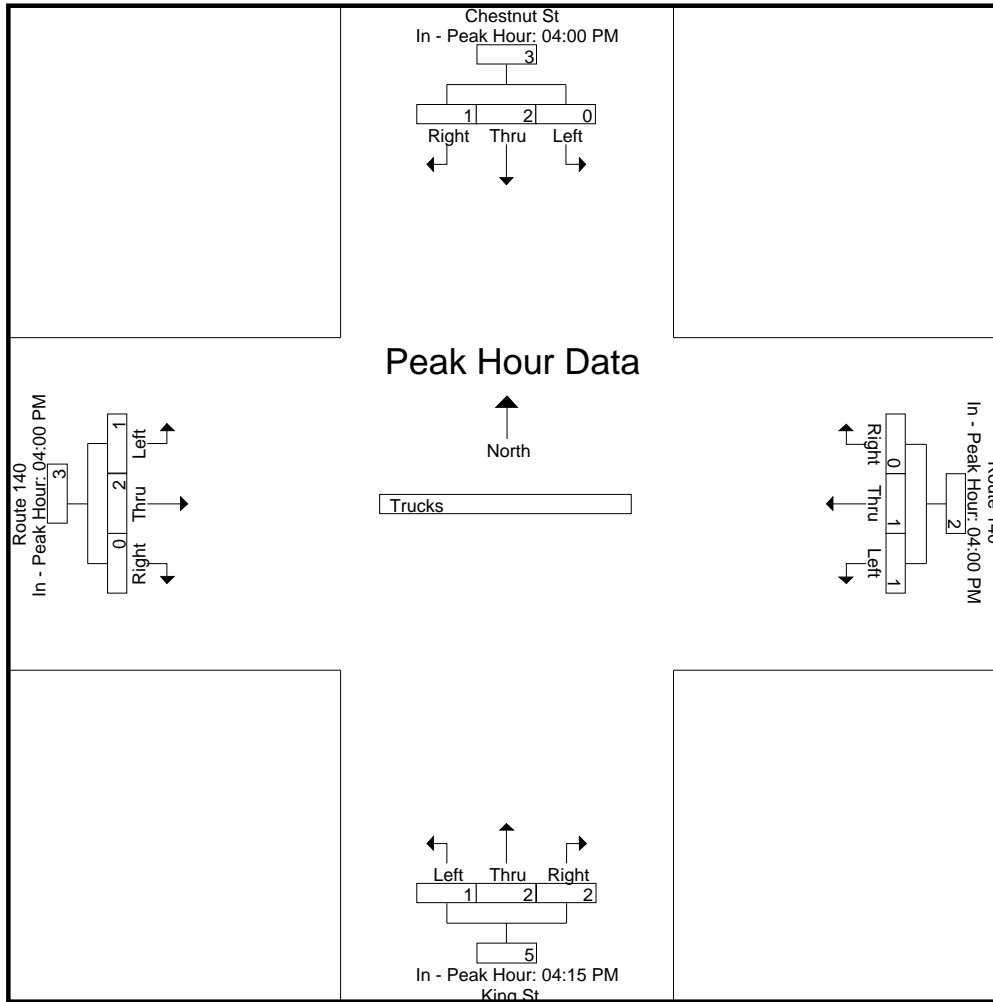

Accurate Counts

978-664-2565

File Name : 66410001

Site Code : 66410001

Start Date : 3/5/2020

Page No : 10

N/S Street : Chestnut St / King St

E/W Street : Route 140

City/State : Franklin, MA

Weather : Clear

Groups Printed- Bikes Peds

Start Time	Chestnut St From North				Route 140 From East				King St From South				Route 140 From West				Exclu. Total	Inclu. Total	Int. Total
	Left	Thru	Right	Peds	Left	Thru	Right	Peds	Left	Thru	Right	Peds	Left	Thru	Right	Peds			
04:00 PM	0	0	0	4	0	0	0	0	0	0	0	0	0	0	0	2	6	0	6
04:15 PM	0	0	1	0	0	0	0	0	0	0	0	5	0	0	0	0	5	1	6
04:30 PM	0	0	0	3	0	0	0	0	0	0	0	1	0	0	0	1	5	0	5
04:45 PM	0	0	0	3	0	0	0	0	0	0	0	1	0	0	0	2	6	0	6
Total	0	0	1	10	0	0	0	0	0	0	0	7	0	0	0	5	22	1	23
05:00 PM	0	0	0	0	0	0	0	0	0	0	0	2	0	0	0	0	2	0	2
05:15 PM	0	0	0	2	0	0	0	0	0	0	0	0	1	0	0	0	2	1	3
05:30 PM	0	0	0	2	0	0	0	0	0	0	0	1	0	0	0	0	3	0	3
05:45 PM	0	0	0	0	0	0	0	0	0	0	0	0	0	0	0	0	0	0	0
Total	0	0	0	4	0	0	0	0	0	0	0	3	1	0	0	0	7	1	8
Grand Total	0	0	1	14	0	0	0	0	0	0	0	10	1	0	0	5	29	2	31
Apprch %	0	0	100		0	0	0		0	0	0		100	0	0				
Total %	0	0	50		0	0	0		0	0	0		50	0	0		93.5	6.5	

Start Time	Chestnut St From North				Route 140 From East				King St From South				Route 140 From West				Int. Total	
	Left	Thru	Right	App. Total	Left	Thru	Right	App. Total	Left	Thru	Right	App. Total	Left	Thru	Right	App. Total		
Peak Hour Analysis From 04:00 PM to 05:45 PM - Peak 1 of 1																		
Peak Hour for Entire Intersection Begins at 04:00 PM																		
04:00 PM	0	0	0	0	0	0	0	0	0	0	0	0	0	0	0	0	0	0
04:15 PM	0	0	1	1	0	0	0	0	0	0	0	0	0	0	0	0	0	1
04:30 PM	0	0	0	0	0	0	0	0	0	0	0	0	0	0	0	0	0	0
04:45 PM	0	0	0	0	0	0	0	0	0	0	0	0	0	0	0	0	0	0
Total Volume	0	0	1	1	0	0	0	0	0	0	0	0	0	0	0	0	0	1
% App. Total	0	0	100		0	0	0		0	0	0		0	0	0			
PHF	.000	.000	.250	.250	.000	.000	.000	.000	.000	.000	.000	.000	.000	.000	.000	.000	.000	.250

Accurate Counts
978-664-2565

File Name : 66410001
Site Code : 66410001
Start Date : 3/5/2020
Page No : 11

N/S Street : Chestnut St / King St
E/W Street : Route 140
City/State : Franklin, MA
Weather : Clear

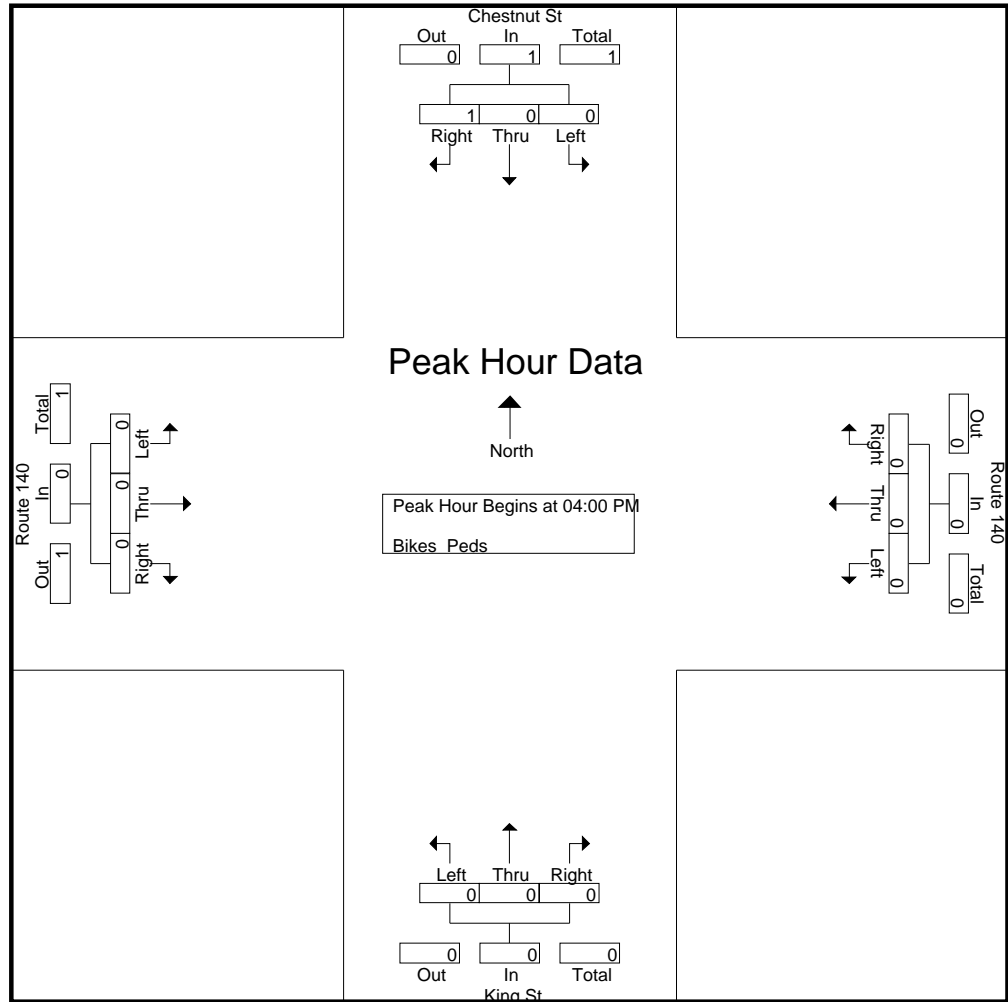

Peak Hour Analysis From 04:00 PM to 05:45 PM - Peak 1 of 1
Peak Hour for Each Approach Begins at:

	04:00 PM				04:00 PM				04:30 PM							
+0 mins.	0	0	0	0	0	0	0	0	0	0	0	0	0	0	0	0
+15 mins.	0	0	1	1	0	0	0	0	0	0	0	0	0	0	0	0
+30 mins.	0	0	0	0	0	0	0	0	0	0	0	0	0	0	0	0
+45 mins.	0	0	0	0	0	0	0	0	0	0	0	0	1	0	0	1
Total Volume	0	0	1	1	0	0	0	0	0	0	0	0	1	0	0	1
% App. Total	0	0	100		0	0	0		0	0	0		100	0	0	
PHF	.000	.000	.250	.250	.000	.000	.000	.000	.000	.000	.000	.000	.250	.000	.000	.250

Accurate Counts
978-664-2565

File Name : 66410001
Site Code : 66410001
Start Date : 3/5/2020
Page No : 12

N/S Street : Chestnut St / King St
E/W Street : Route 140
City/State : Franklin, MA
Weather : Clear

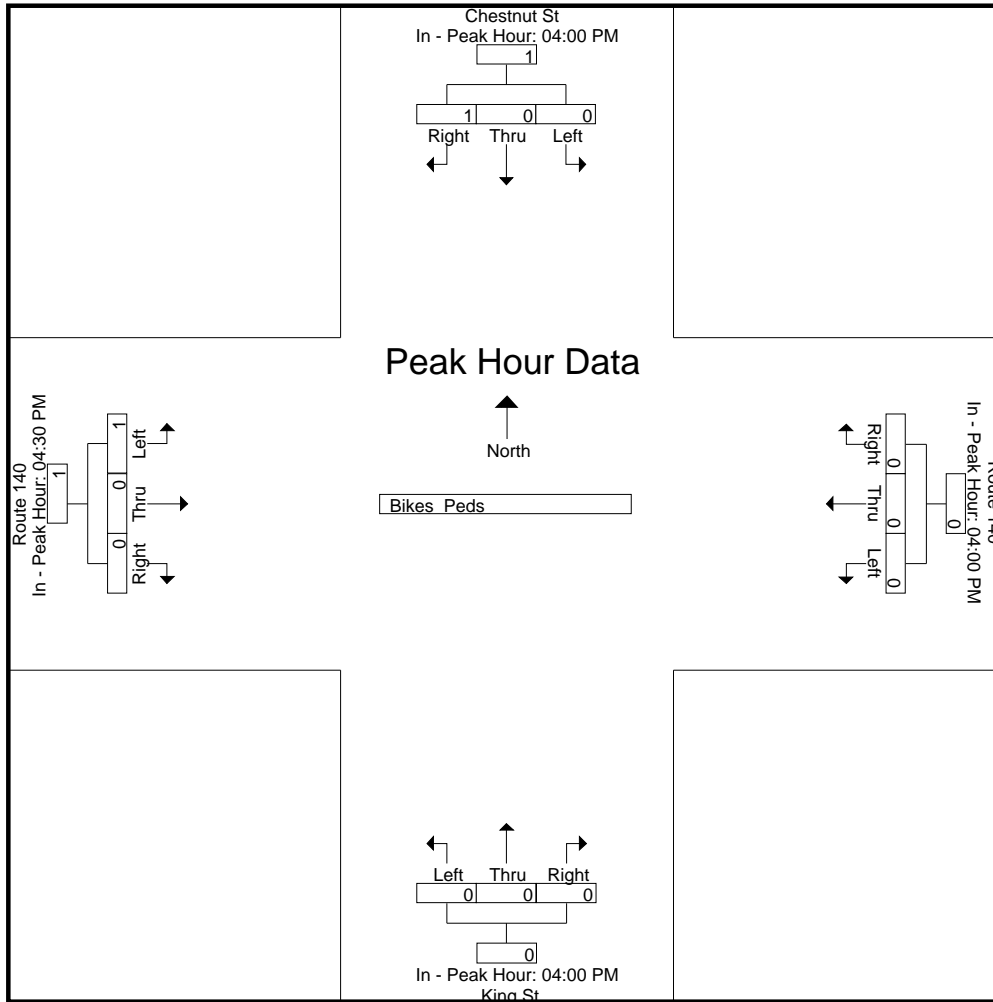

Accurate Counts

978-664-2565

N/S Street : Horace Mann Plaza / CVS
 E/W Street : Route 140
 City/State : Franklin, MA
 Weather : Clear

File Name : 66410002
 Site Code : 66410002
 Start Date : 3/5/2020
 Page No : 1

Groups Printed- Cars - Trucks

Start Time	Horace Mann Plaza From North			Route 140 From East			CVS From South			Route 140 From West			Int. Total
	Left	Thru	Right	Left	Thru	Right	Left	Thru	Right	Left	Thru	Right	
07:00 AM	4	1	3	1	107	10	2	0	4	9	90	1	232
07:15 AM	9	2	17	1	95	20	1	2	4	15	127	5	298
07:30 AM	10	1	14	3	94	12	2	2	2	18	131	5	294
07:45 AM	11	5	15	2	89	16	2	1	6	9	126	10	292
Total	34	9	49	7	385	58	7	5	16	51	474	21	1116
08:00 AM	12	0	14	4	97	11	8	0	2	13	112	3	276
08:15 AM	15	1	21	0	87	11	4	1	2	13	130	5	290
08:30 AM	22	3	10	2	106	12	1	3	2	20	117	5	303
08:45 AM	16	1	11	1	120	16	5	0	5	37	126	5	343
Total	65	5	56	7	410	50	18	4	11	83	485	18	1212
Grand Total	99	14	105	14	795	108	25	9	27	134	959	39	2328
Apprch %	45.4	6.4	48.2	1.5	86.7	11.8	41	14.8	44.3	11.8	84.7	3.4	
Total %	4.3	0.6	4.5	0.6	34.1	4.6	1.1	0.4	1.2	5.8	41.2	1.7	
Cars	99	14	105	14	788	108	25	9	27	134	943	39	2305
% Cars	100	100	100	100	99.1	100	100	100	100	100	98.3	100	99
Trucks	0	0	0	0	7	0	0	0	0	0	16	0	23
% Trucks	0	0	0	0	0.9	0	0	0	0	0	1.7	0	1

Start Time	Horace Mann Plaza From North				Route 140 From East				CVS From South				Route 140 From West				Int. Total
	Left	Thru	Right	App. Total	Left	Thru	Right	App. Total	Left	Thru	Right	App. Total	Left	Thru	Right	App. Total	
Peak Hour Analysis From 07:00 AM to 08:45 AM - Peak 1 of 1																	
Peak Hour for Entire Intersection Begins at 08:00 AM																	
08:00 AM	12	0	14	26	4	97	11	112	8	0	2	10	13	112	3	128	276
08:15 AM	15	1	21	37	0	87	11	98	4	1	2	7	13	130	5	148	290
08:30 AM	22	3	10	35	2	106	12	120	1	3	2	6	20	117	5	142	303
08:45 AM	16	1	11	28	1	120	16	137	5	0	5	10	37	126	5	168	343
Total Volume	65	5	56	126	7	410	50	467	18	4	11	33	83	485	18	586	1212
% App. Total	51.6	4	44.4		1.5	87.8	10.7		54.5	12.1	33.3		14.2	82.8	3.1		
PHF	.739	.417	.667	.851	.438	.854	.781	.852	.563	.333	.550	.825	.561	.933	.900	.872	.883
Cars	65	5	56	126	7	408	50	465	18	4	11	33	83	475	18	576	1200
% Cars	100	100	100	100	100	99.5	100	99.6	100	100	100	100	100	97.9	100	98.3	99.0
Trucks	0	0	0	0	0	2	0	2	0	0	0	0	0	10	0	10	12
% Trucks	0	0	0	0	0	0.5	0	0.4	0	0	0	0	0	2.1	0	1.7	1.0

Accurate Counts

978-664-2565

File Name : 66410002

Site Code : 66410002

Start Date : 3/5/2020

Page No : 2

N/S Street : Horace Mann Plaza / CVS

E/W Street : Route 140

City/State : Franklin, MA

Weather : Clear

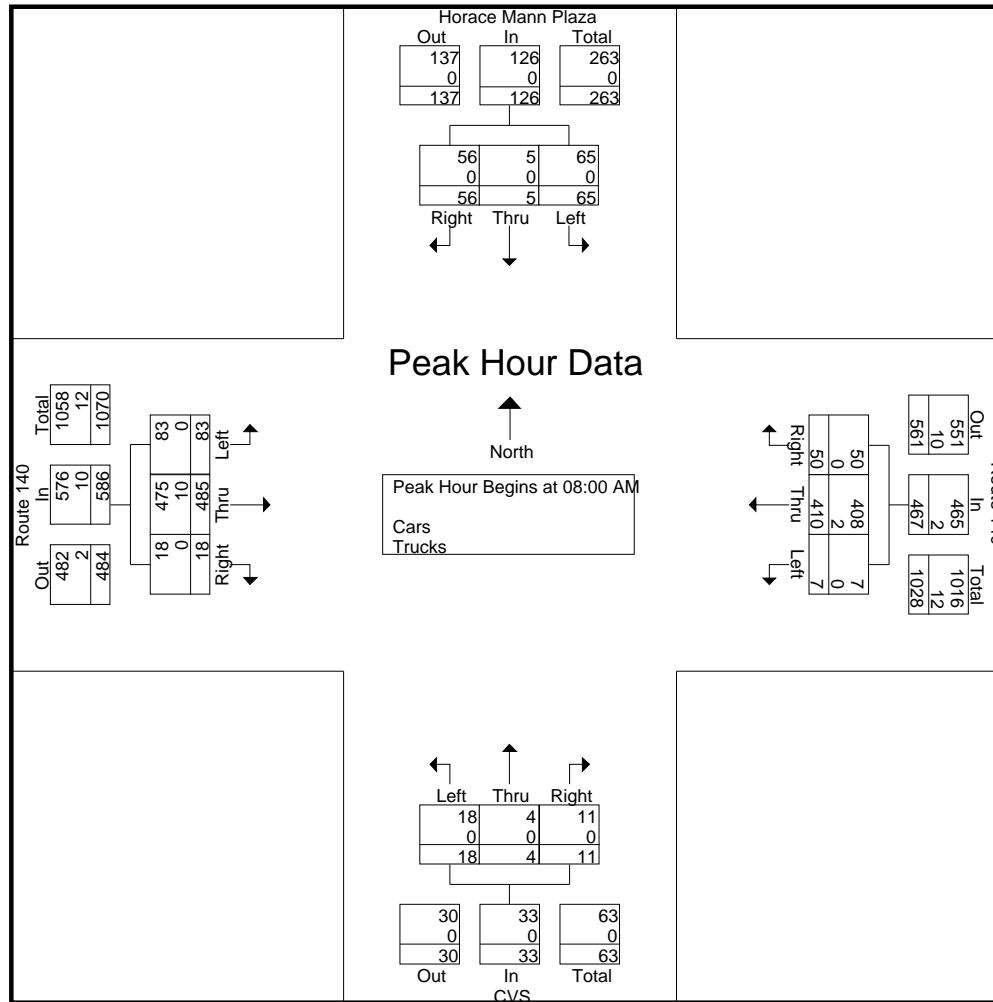

Peak Hour Analysis From 07:00 AM to 08:45 AM - Peak 1 of 1

Peak Hour for Each Approach Begins at:

	07:45 AM				08:00 AM				08:00 AM				08:00 AM			
+0 mins.	11	5	15	31	4	97	11	112	8	0	2	10	13	112	3	128
+15 mins.	12	0	14	26	0	87	11	98	4	1	2	7	13	130	5	148
+30 mins.	15	1	21	37	2	106	12	120	1	3	2	6	20	117	5	142
+45 mins.	22	3	10	35	1	120	16	137	5	0	5	10	37	126	5	168
Total Volume	60	9	60	129	7	410	50	467	18	4	11	33	83	485	18	586
% App. Total	46.5	7	46.5		1.5	87.8	10.7		54.5	12.1	33.3		14.2	82.8	3.1	
PHF	.682	.450	.714	.872	.438	.854	.781	.852	.563	.333	.550	.825	.561	.933	.900	.872
Cars	60	9	60	129	7	408	50	465	18	4	11	33	83	475	18	576
% Cars	100	100	100	100	100	99.5	100	99.6	100	100	100	100	100	97.9	100	98.3
Trucks	0	0	0	0	0	2	0	2	0	0	0	0	0	10	0	10

Accurate Counts
978-664-2565

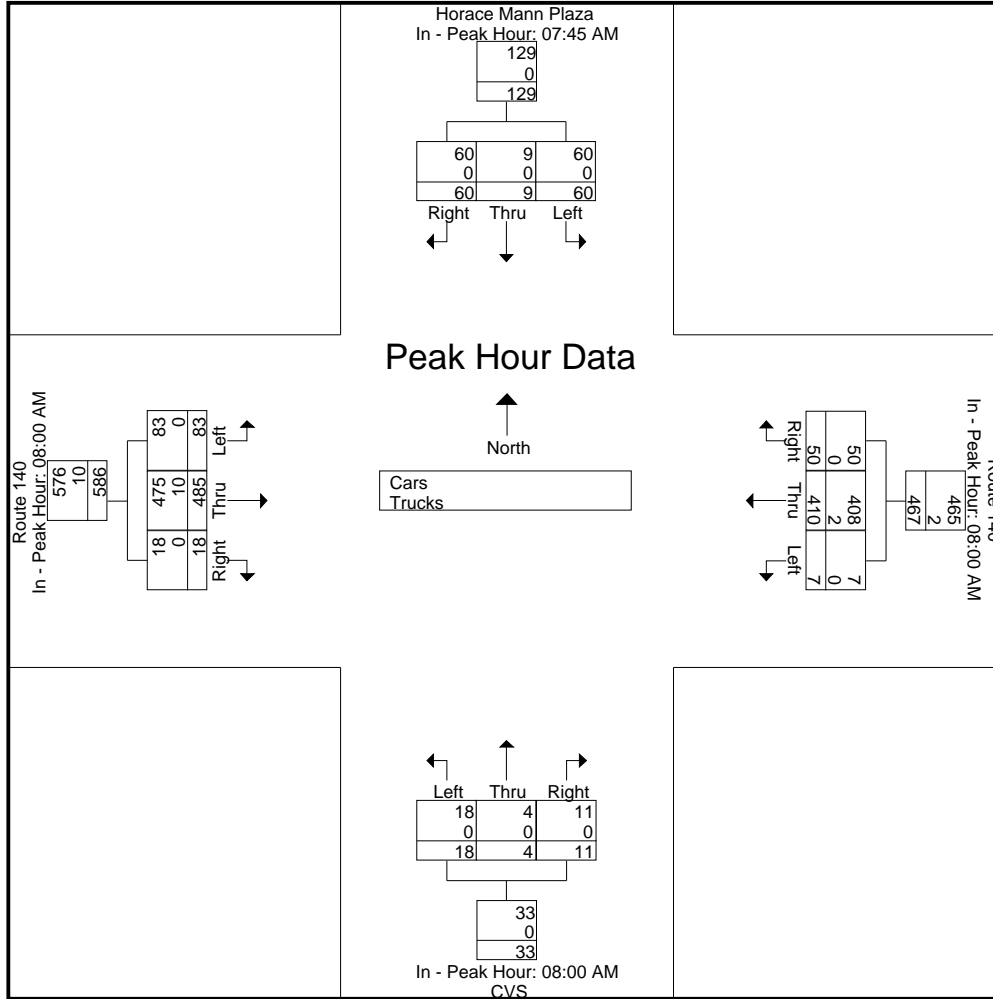

Accurate Counts

978-664-2565

File Name : 66410002

Site Code : 66410002

Start Date : 3/5/2020

Page No : 4

N/S Street : Horace Mann Plaza / CVS

E/W Street : Route 140

City/State : Franklin, MA

Weather : Clear

Groups Printed- Cars

Start Time	Horace Mann Plaza From North			Route 140 From East			CVS From South			Route 140 From West			Int. Total
	Left	Thru	Right	Left	Thru	Right	Left	Thru	Right	Left	Thru	Right	
07:00 AM	4	1	3	1	104	10	2	0	4	9	89	1	228
07:15 AM	9	2	17	1	93	20	1	2	4	15	124	5	293
07:30 AM	10	1	14	3	94	12	2	2	2	18	130	5	293
07:45 AM	11	5	15	2	89	16	2	1	6	9	125	10	291
Total	34	9	49	7	380	58	7	5	16	51	468	21	1105
08:00 AM	12	0	14	4	96	11	8	0	2	13	110	3	273
08:15 AM	15	1	21	0	87	11	4	1	2	13	124	5	284
08:30 AM	22	3	10	2	105	12	1	3	2	20	116	5	301
08:45 AM	16	1	11	1	120	16	5	0	5	37	125	5	342
Total	65	5	56	7	408	50	18	4	11	83	475	18	1200
Grand Total	99	14	105	14	788	108	25	9	27	134	943	39	2305
Apprch %	45.4	6.4	48.2	1.5	86.6	11.9	41	14.8	44.3	12	84.5	3.5	
Total %	4.3	0.6	4.6	0.6	34.2	4.7	1.1	0.4	1.2	5.8	40.9	1.7	

Start Time	Horace Mann Plaza From North				Route 140 From East				CVS From South				Route 140 From West				Int. Total
	Left	Thru	Right	App. Total	Left	Thru	Right	App. Total	Left	Thru	Right	App. Total	Left	Thru	Right	App. Total	
Peak Hour Analysis From 07:00 AM to 08:45 AM - Peak 1 of 1																	
Peak Hour for Entire Intersection Begins at 08:00 AM																	
08:00 AM	12	0	14	26	4	96	11	111	8	0	2	10	13	110	3	126	273
08:15 AM	15	1	21	37	0	87	11	98	4	1	2	7	13	124	5	142	284
08:30 AM	22	3	10	35	2	105	12	119	1	3	2	6	20	116	5	141	301
08:45 AM	16	1	11	28	1	120	16	137	5	0	5	10	37	125	5	167	342
Total Volume	65	5	56	126	7	408	50	465	18	4	11	33	83	475	18	576	1200
% App. Total	51.6	4	44.4		1.5	87.7	10.8		54.5	12.1	33.3		14.4	82.5	3.1		
PHF	.739	.417	.667	.851	.438	.850	.781	.849	.563	.333	.550	.825	.561	.950	.900	.862	.877

Accurate Counts

978-664-2565

File Name : 66410002
 Site Code : 66410002
 Start Date : 3/5/2020
 Page No : 5

N/S Street : Horace Mann Plaza / CVS
 E/W Street : Route 140
 City/State : Franklin, MA
 Weather : Clear

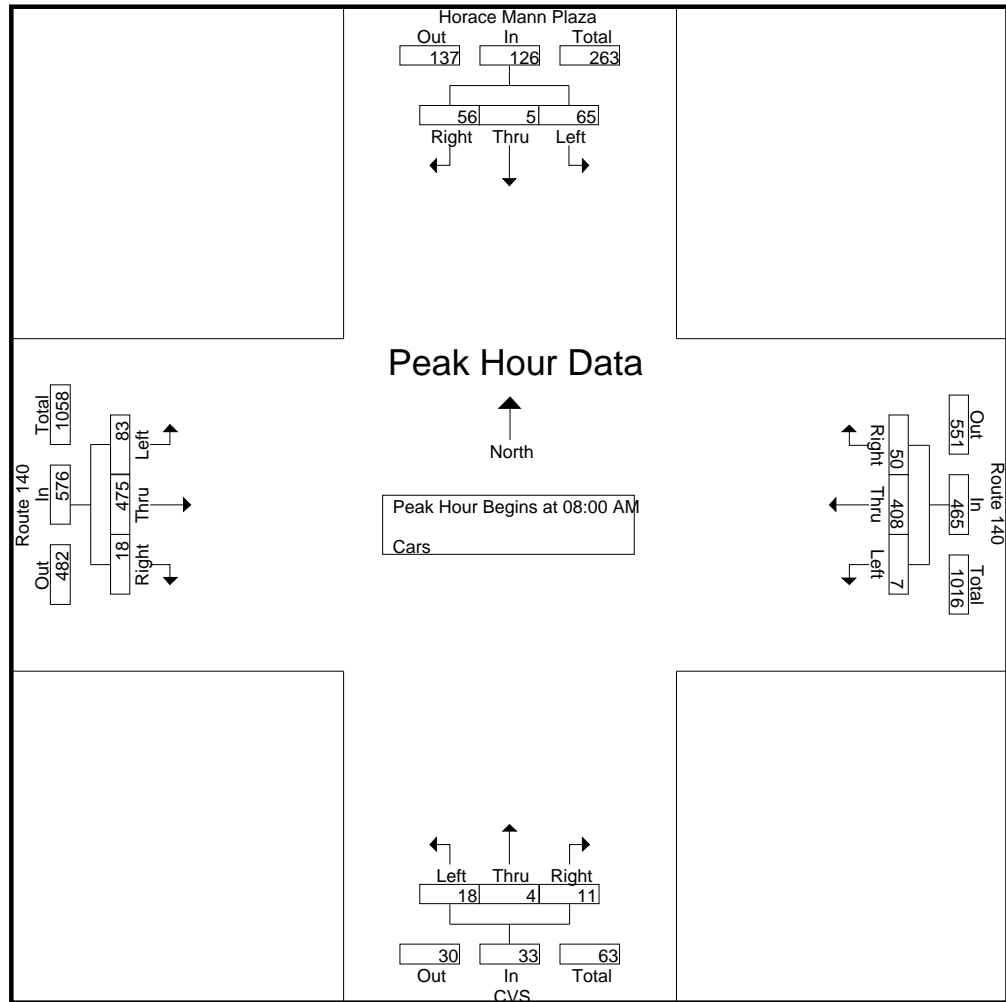

Peak Hour Analysis From 07:00 AM to 08:45 AM - Peak 1 of 1

Peak Hour for Each Approach Begins at:

	07:45 AM				08:00 AM				08:00 AM				08:00 AM			
+0 mins.	11	5	15	31	4	96	11	111	8	0	2	10	13	110	3	126
+15 mins.	12	0	14	26	0	87	11	98	4	1	2	7	13	124	5	142
+30 mins.	15	1	21	37	2	105	12	119	1	3	2	6	20	116	5	141
+45 mins.	22	3	10	35	1	120	16	137	5	0	5	10	37	125	5	167
Total Volume	60	9	60	129	7	408	50	465	18	4	11	33	83	475	18	576
% App. Total	46.5	7	46.5		1.5	87.7	10.8		54.5	12.1	33.3		14.4	82.5	3.1	
PHF	.682	.450	.714	.872	.438	.850	.781	.849	.563	.333	.550	.825	.561	.950	.900	.862

Accurate Counts
978-664-2565

File Name : 66410002
Site Code : 66410002
Start Date : 3/5/2020
Page No : 6

N/S Street : Horace Mann Plaza / CVS
E/W Street : Route 140
City/State : Franklin, MA
Weather : Clear

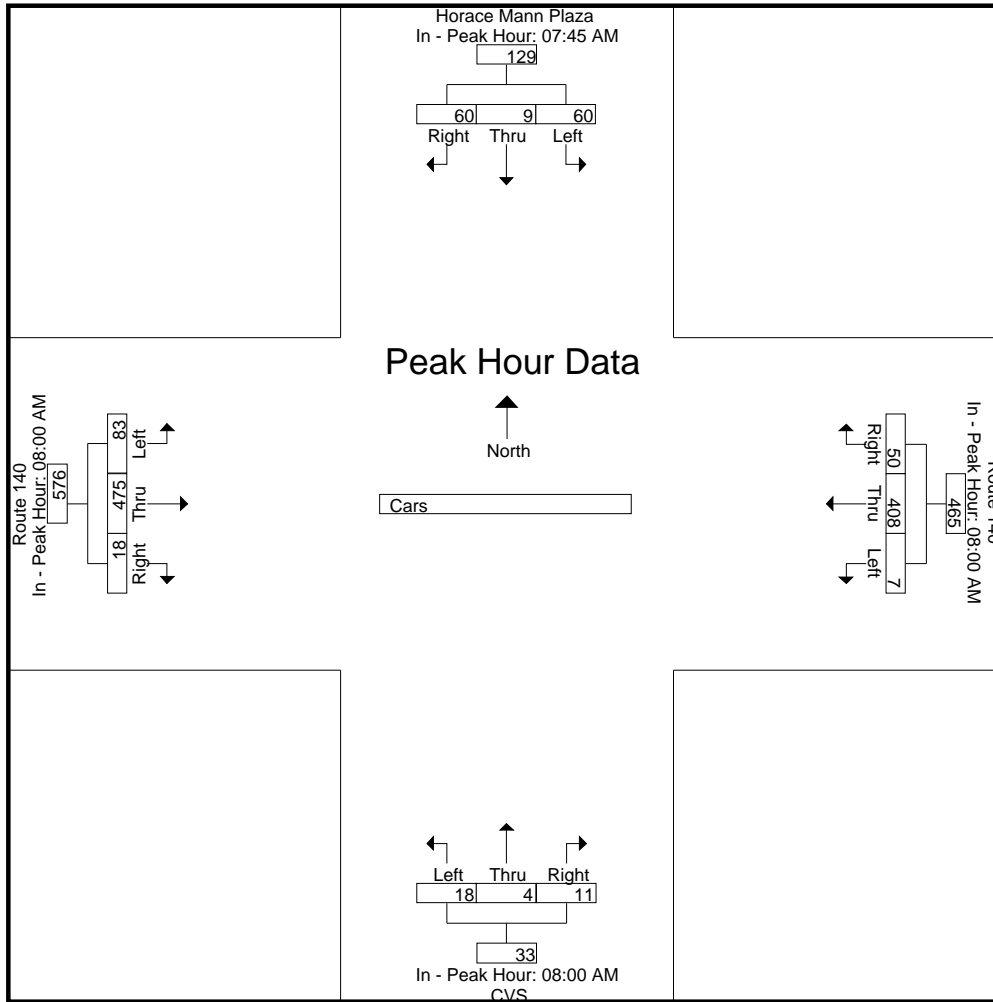

Accurate Counts

978-664-2565

N/S Street : Horace Mann Plaza / CVS
 E/W Street : Route 140
 City/State : Franklin, MA
 Weather : Clear

File Name : 66410002
 Site Code : 66410002
 Start Date : 3/5/2020
 Page No : 7

Groups Printed- Trucks

Start Time	Horace Mann Plaza From North			Route 140 From East			CVS From South			Route 140 From West			Int. Total
	Left	Thru	Right	Left	Thru	Right	Left	Thru	Right	Left	Thru	Right	
07:00 AM	0	0	0	0	3	0	0	0	0	0	1	0	4
07:15 AM	0	0	0	0	2	0	0	0	0	0	3	0	5
07:30 AM	0	0	0	0	0	0	0	0	0	0	1	0	1
07:45 AM	0	0	0	0	0	0	0	0	0	0	1	0	1
Total	0	0	0	0	5	0	0	0	0	0	6	0	11
08:00 AM	0	0	0	0	1	0	0	0	0	0	2	0	3
08:15 AM	0	0	0	0	0	0	0	0	0	0	6	0	6
08:30 AM	0	0	0	0	1	0	0	0	0	0	1	0	2
08:45 AM	0	0	0	0	0	0	0	0	0	0	1	0	1
Total	0	0	0	0	2	0	0	0	0	0	10	0	12
Grand Total	0	0	0	0	7	0	0	0	0	0	16	0	23
Apprch %	0	0	0	0	100	0	0	0	0	0	100	0	
Total %	0	0	0	0	30.4	0	0	0	0	0	69.6	0	

Start Time	Horace Mann Plaza From North				Route 140 From East				CVS From South				Route 140 From West				Int. Total
	Left	Thru	Right	App. Total	Left	Thru	Right	App. Total	Left	Thru	Right	App. Total	Left	Thru	Right	App. Total	
Peak Hour Analysis From 07:00 AM to 08:45 AM - Peak 1 of 1																	
Peak Hour for Entire Intersection Begins at 07:45 AM																	
07:45 AM	0	0	0	0	0	0	0	0	0	0	0	0	0	1	0	1	
08:00 AM	0	0	0	0	0	1	0	1	0	0	0	0	0	2	0	2	
08:15 AM	0	0	0	0	0	0	0	0	0	0	0	0	0	6	0	6	
08:30 AM	0	0	0	0	0	1	0	1	0	0	0	0	0	1	0	1	
Total Volume	0	0	0	0	0	2	0	2	0	0	0	0	0	10	0	10	
% App. Total	0	0	0	0	0	100	0	0	0	0	0	0	0	100	0	0	
PHF	.000	.000	.000	.000	.000	.500	.000	.500	.000	.000	.000	.000	.000	.417	.000	.417	

Accurate Counts

978-664-2565

File Name : 66410002

Site Code : 66410002

Start Date : 3/5/2020

Page No : 8

N/S Street : Horace Mann Plaza / CVS

E/W Street : Route 140

City/State : Franklin, MA

Weather : Clear

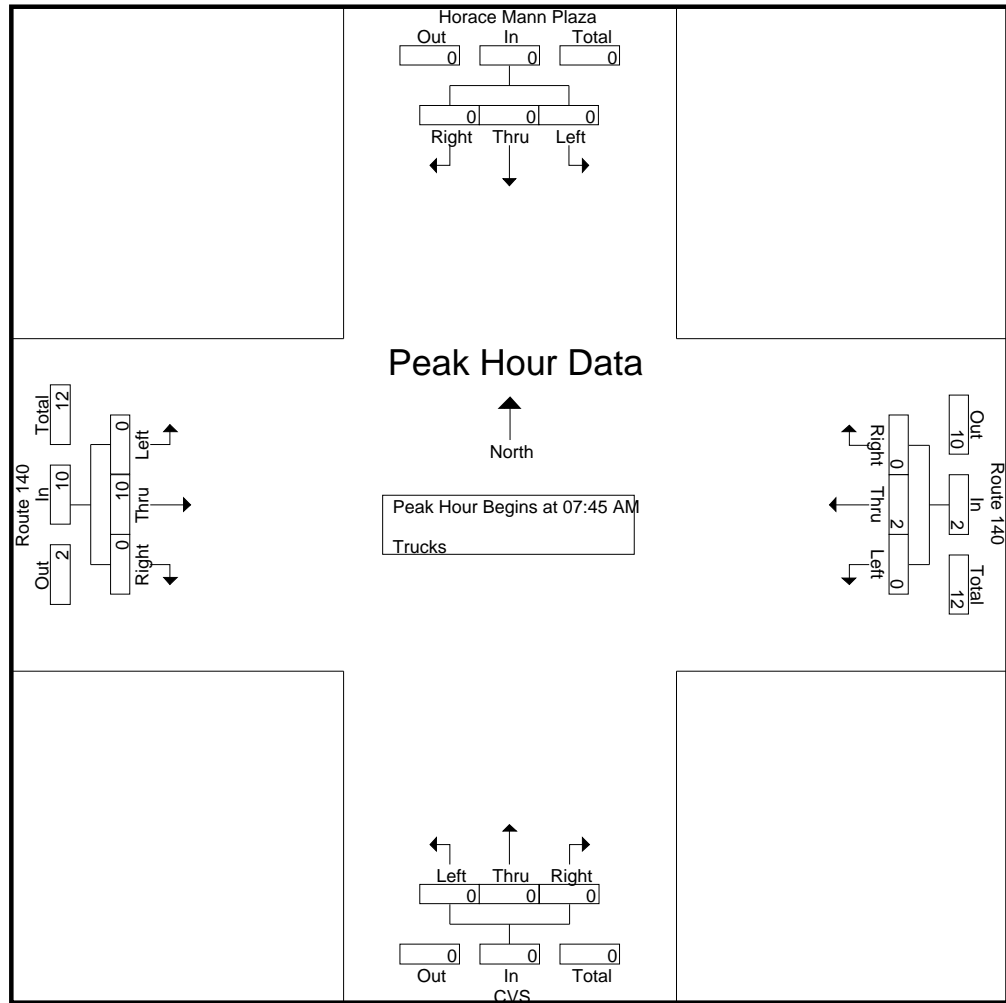

Peak Hour Analysis From 07:00 AM to 08:45 AM - Peak 1 of 1

Peak Hour for Each Approach Begins at:

	07:00 AM				07:00 AM				07:30 AM				07:30 AM			
+0 mins.	0	0	0	0	0	3	0	3	0	0	0	0	0	1	0	1
+15 mins.	0	0	0	0	0	2	0	2	0	0	0	0	0	1	0	1
+30 mins.	0	0	0	0	0	0	0	0	0	0	0	0	0	2	0	2
+45 mins.	0	0	0	0	0	0	0	0	0	0	0	0	0	6	0	6
Total Volume	0	0	0	0	0	5	0	5	0	0	0	0	0	10	0	10
% App. Total	0	0	0	0	0	100	0	100	0	0	0	0	0	100	0	100
PHF	.000	.000	.000	.000	.000	.417	.000	.417	.000	.000	.000	.000	.000	.417	.000	.417

Accurate Counts
978-664-2565

File Name : 66410002
Site Code : 66410002
Start Date : 3/5/2020
Page No : 9

N/S Street : Horace Mann Plaza / CVS
E/W Street : Route 140
City/State : Franklin, MA
Weather : Clear

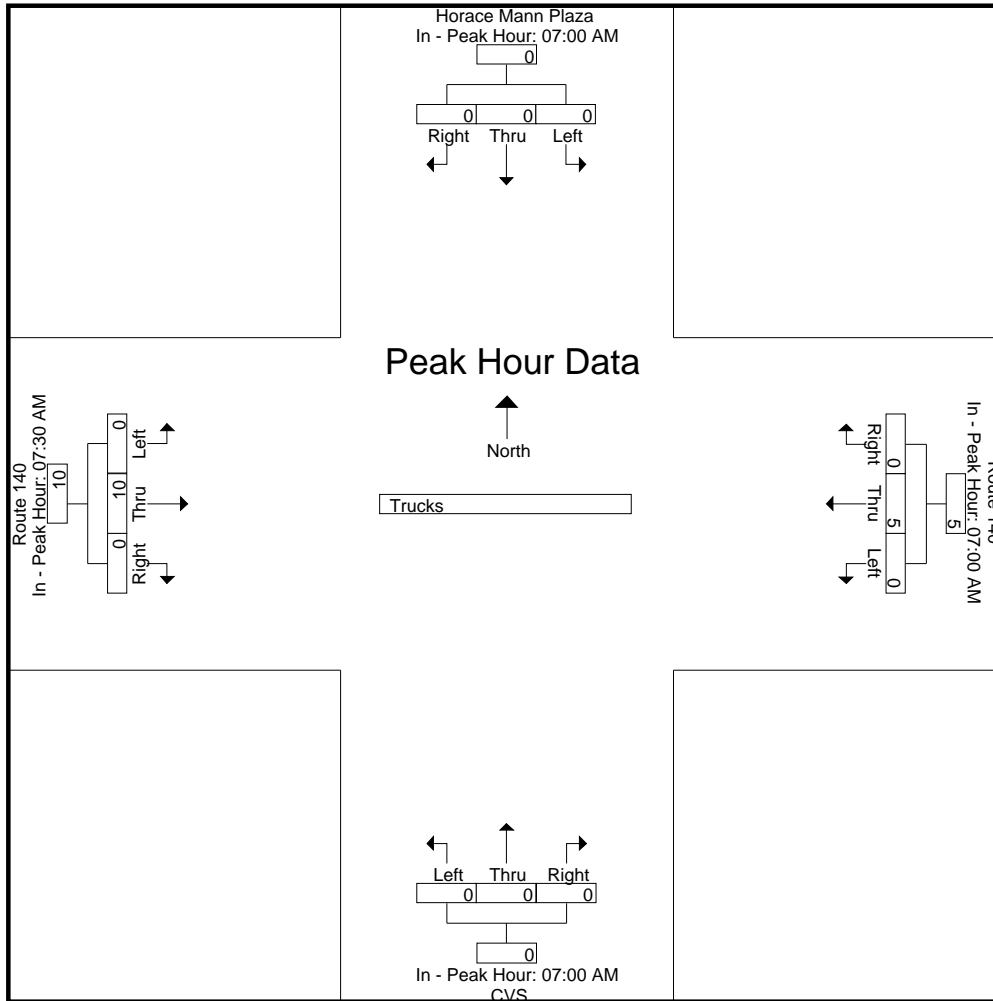

Accurate Counts

978-664-2565

N/S Street : Horace Mann Plaza / CVS
 E/W Street : Route 140
 City/State : Franklin, MA
 Weather : Clear

File Name : 66410002
 Site Code : 66410002
 Start Date : 3/5/2020
 Page No : 10

Groups Printed- Bikes Peds

Start Time	Horace Mann Plaza From North				Route 140 From East				CVS From South				Route 140 From West				Exclu. Total	Inclu. Total	Int. Total
	Left	Thru	Right	Peds	Left	Thru	Right	Peds	Left	Thru	Right	Peds	Left	Thru	Right	Peds			
07:00 AM	0	0	0	0	0	0	0	0	0	0	0	2	0	0	0	0	2	0	2
07:15 AM	0	0	0	0	0	0	0	1	0	0	0	1	0	0	0	0	2	0	2
07:30 AM	0	0	0	0	0	0	0	0	0	0	0	0	0	0	0	0	0	0	0
07:45 AM	0	0	0	2	0	1	0	0	0	0	0	0	0	1	0	0	2	2	4
Total	0	0	0	2	0	1	0	1	0	0	0	3	0	1	0	0	6	2	8
08:00 AM	0	0	0	2	0	0	0	0	0	0	0	0	0	0	0	0	2	0	2
08:15 AM	0	0	0	0	0	0	0	0	0	0	0	1	0	0	0	0	1	0	1
08:30 AM	0	0	0	0	0	0	0	0	0	0	0	0	0	0	0	0	0	0	0
08:45 AM	0	0	0	1	0	0	0	0	0	0	0	0	0	0	0	0	1	0	1
Total	0	0	0	3	0	0	0	0	0	0	0	1	0	0	0	0	4	0	4
Grand Total	0	0	0	5	0	1	0	1	0	0	0	4	0	1	0	0	10	2	12
Apprch %	0	0	0		0	100	0		0	0	0		0	100	0				
Total %	0	0	0		0	50	0		0	0	0		0	50	0		83.3	16.7	

Start Time	Horace Mann Plaza From North				Route 140 From East				CVS From South				Route 140 From West				Int. Total	
	Left	Thru	Right	App. Total	Left	Thru	Right	App. Total	Left	Thru	Right	App. Total	Left	Thru	Right	App. Total		
Peak Hour Analysis From 07:00 AM to 08:45 AM - Peak 1 of 1																		
Peak Hour for Entire Intersection Begins at 07:00 AM																		
07:00 AM	0	0	0	0	0	0	0	0	0	0	0	0	0	0	0	0	0	0
07:15 AM	0	0	0	0	0	0	0	0	0	0	0	0	0	0	0	0	0	0
07:30 AM	0	0	0	0	0	0	0	0	0	0	0	0	0	0	0	0	0	0
07:45 AM	0	0	0	0	0	1	0	1	0	0	0	0	0	1	0	1	0	1
Total Volume	0	0	0	0	0	1	0	1	0	0	0	0	0	1	0	1	0	1
% App. Total	0	0	0		0	100	0		0	0	0		0	100	0			
PHF	.000	.000	.000	.000	.000	.250	.000	.250	.000	.000	.000	.000	.000	.250	.000	.250		.250

Accurate Counts

978-664-2565

File Name : 66410002

Site Code : 66410002

Start Date : 3/5/2020

Page No : 11

N/S Street : Horace Mann Plaza / CVS

E/W Street : Route 140

City/State : Franklin, MA

Weather : Clear

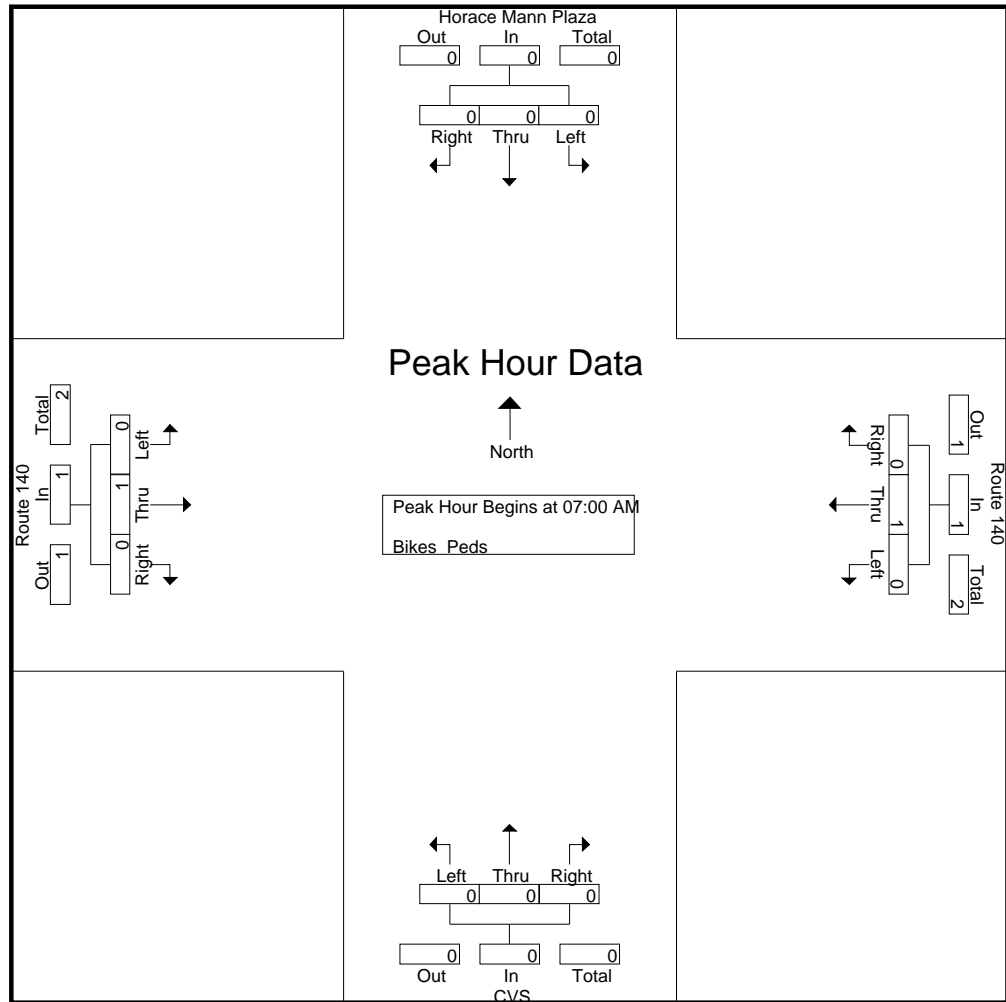

Peak Hour Analysis From 07:00 AM to 08:45 AM - Peak 1 of 1

Peak Hour for Each Approach Begins at:

	07:00 AM				07:00 AM				07:00 AM				07:00 AM			
+0 mins.	0	0	0	0	0	0	0	0	0	0	0	0	0	0	0	0
+15 mins.	0	0	0	0	0	0	0	0	0	0	0	0	0	0	0	0
+30 mins.	0	0	0	0	0	0	0	0	0	0	0	0	0	0	0	0
+45 mins.	0	0	0	0	0	1	0	1	0	0	0	0	0	1	0	1
Total Volume	0	0	0	0	0	1	0	1	0	0	0	0	0	1	0	1
% App. Total	0	0	0	0	0	100	0	0	0	0	0	0	0	100	0	0
PHF	.000	.000	.000	.000	.000	.250	.000	.250	.000	.000	.000	.000	.000	.250	.000	.250

Accurate Counts
978-664-2565

File Name : 66410002
Site Code : 66410002
Start Date : 3/5/2020
Page No : 12

N/S Street : Horace Mann Plaza / CVS
E/W Street : Route 140
City/State : Franklin, MA
Weather : Clear

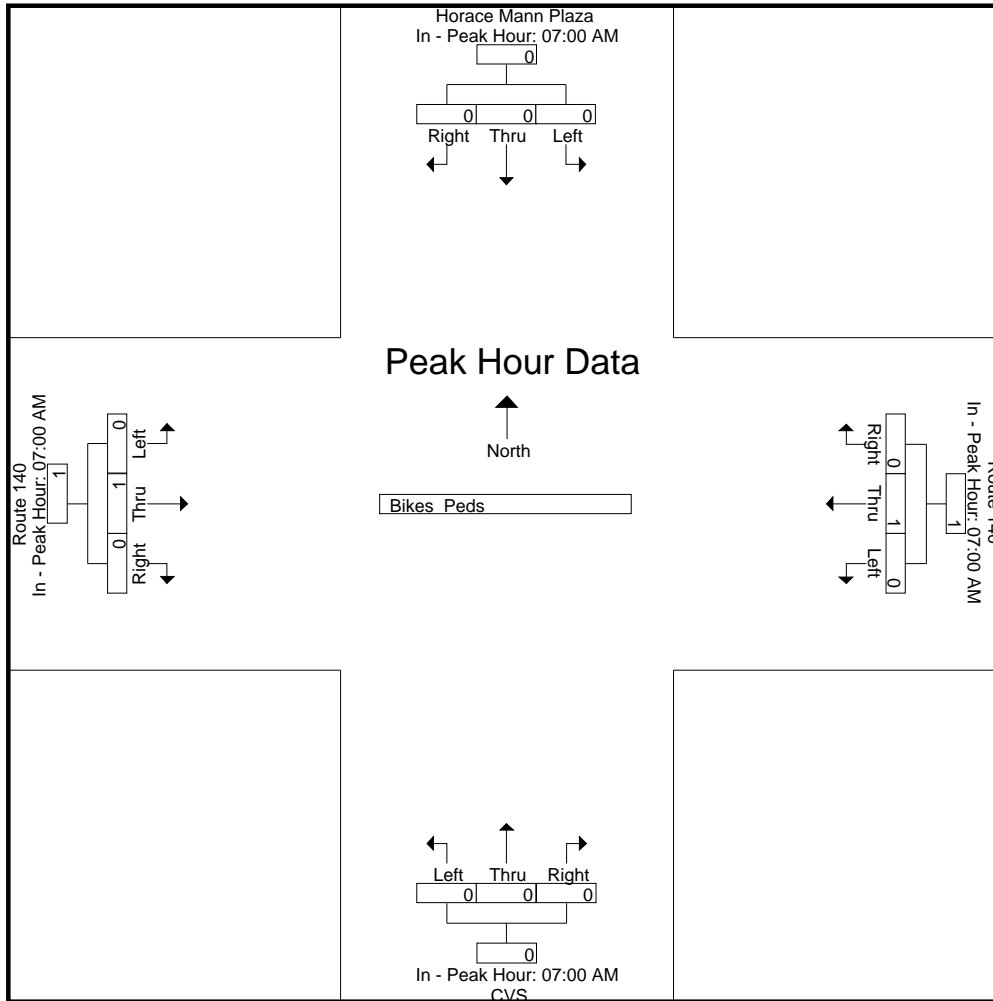

Accurate Counts

978-664-2565

File Name : 66410002

Site Code : 66410002

Start Date : 3/5/2020

Page No : 1

N/S Street : Horace Mann Plaza / CVS

E/W Street : Route 140

City/State : Franklin, MA

Weather : Clear

Groups Printed- Cars - Trucks

Start Time	Horace Mann Plaza From North			Route 140 From East			CVS From South			Route 140 From West			Int. Total
	Left	Thru	Right	Left	Thru	Right	Left	Thru	Right	Left	Thru	Right	
04:00 PM	24	3	51	9	156	29	8	4	9	24	100	12	429
04:15 PM	24	4	48	3	151	29	9	4	8	30	110	10	430
04:30 PM	23	4	47	5	133	27	11	3	7	29	121	11	421
04:45 PM	30	4	49	6	155	28	5	8	8	53	128	11	485
Total	101	15	195	23	595	113	33	19	32	136	459	44	1765
05:00 PM	32	3	47	2	173	33	9	3	6	53	122	9	492
05:15 PM	31	4	45	5	157	37	7	3	10	41	132	12	484
05:30 PM	28	2	56	4	126	26	11	5	4	37	100	14	413
05:45 PM	37	4	47	3	98	24	4	6	11	37	116	11	398
Total	128	13	195	14	554	120	31	17	31	168	470	46	1787
Grand Total	229	28	390	37	1149	233	64	36	63	304	929	90	3552
Apprch %	35.4	4.3	60.3	2.6	81	16.4	39.3	22.1	38.7	23	70.2	6.8	
Total %	6.4	0.8	11	1	32.3	6.6	1.8	1	1.8	8.6	26.2	2.5	
Cars	228	28	390	37	1142	233	64	36	63	304	922	90	3537
% Cars	99.6	100	100	100	99.4	100	100	100	100	100	99.2	100	99.6
Trucks	1	0	0	0	7	0	0	0	0	0	7	0	15
% Trucks	0.4	0	0	0	0.6	0	0	0	0	0	0.8	0	0.4

Start Time	Horace Mann Plaza From North				Route 140 From East				CVS From South				Route 140 From West				Int. Total
	Left	Thru	Right	App. Total	Left	Thru	Right	App. Total	Left	Thru	Right	App. Total	Left	Thru	Right	App. Total	
Peak Hour Analysis From 04:00 PM to 05:45 PM - Peak 1 of 1																	
Peak Hour for Entire Intersection Begins at 04:30 PM																	
04:30 PM	23	4	47	74	5	133	27	165	11	3	7	21	29	121	11	161	421
04:45 PM	30	4	49	83	6	155	28	189	5	8	8	21	53	128	11	192	485
05:00 PM	32	3	47	82	2	173	33	208	9	3	6	18	53	122	9	184	492
05:15 PM	31	4	45	80	5	157	37	199	7	3	10	20	41	132	12	185	484
Total Volume	116	15	188	319	18	618	125	761	32	17	31	80	176	503	43	722	1882
% App. Total	36.4	4.7	58.9		2.4	81.2	16.4		40	21.2	38.8		24.4	69.7	6		
PHF	.906	.938	.959	.961	.750	.893	.845	.915	.727	.531	.775	.952	.830	.953	.896	.940	.956
Cars	116	15	188	319	18	615	125	758	32	17	31	80	176	499	43	718	1875
% Cars	100	100	100	100	100	99.5	100	99.6	100	100	100	100	100	99.2	100	99.4	99.6
Trucks	0	0	0	0	0	3	0	3	0	0	0	0	0	4	0	4	7
% Trucks	0	0	0	0	0	0.5	0	0.4	0	0	0	0	0	0.8	0	0.6	0.4

Accurate Counts

978-664-2565

File Name : 66410002
 Site Code : 66410002
 Start Date : 3/5/2020
 Page No : 2

N/S Street : Horace Mann Plaza / CVS
 E/W Street : Route 140
 City/State : Franklin, MA
 Weather : Clear

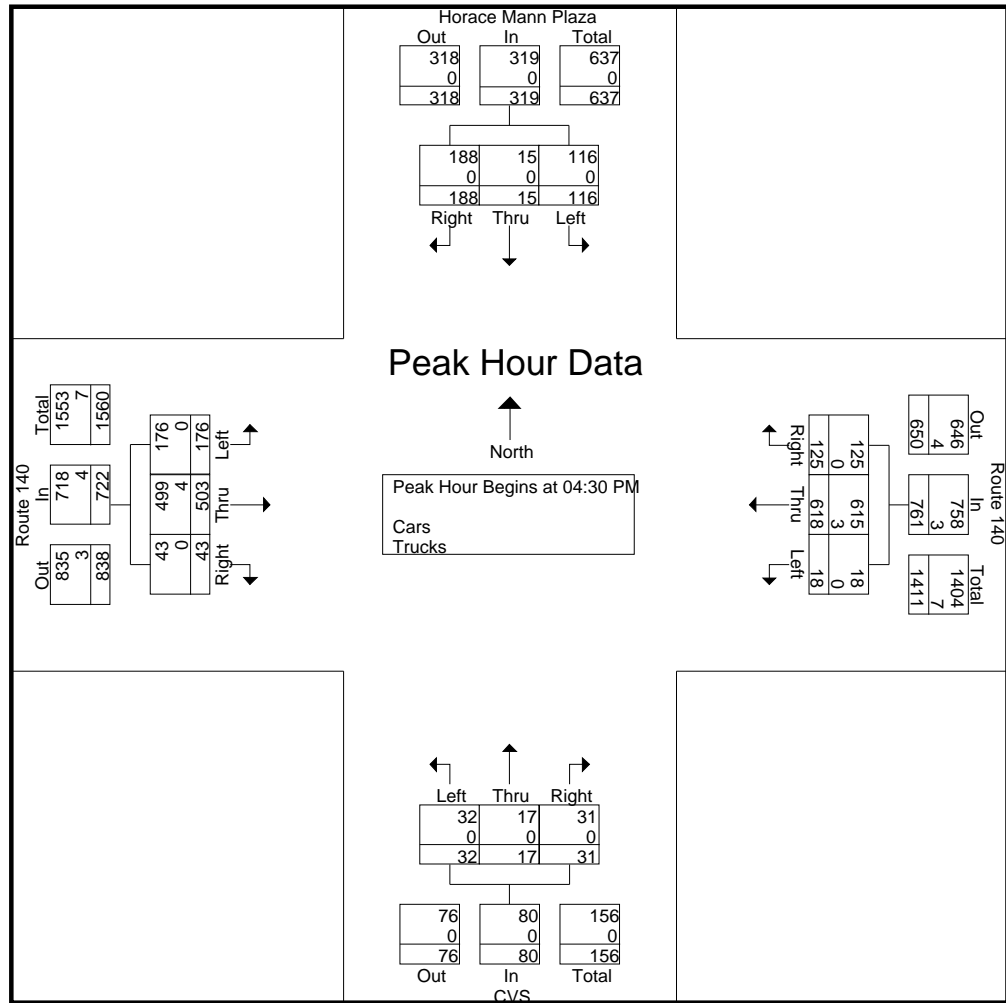

Peak Hour Analysis From 04:00 PM to 05:45 PM - Peak 1 of 1

Peak Hour for Each Approach Begins at:

	05:00 PM				04:30 PM				04:00 PM				04:30 PM			
+0 mins.	32	3	47	82	5	133	27	165	8	4	9	21	29	121	11	161
+15 mins.	31	4	45	80	6	155	28	189	9	4	8	21	53	128	11	192
+30 mins.	28	2	56	86	2	173	33	208	11	3	7	21	53	122	9	184
+45 mins.	37	4	47	88	5	157	37	199	5	8	8	21	41	132	12	185
Total Volume	128	13	195	336	18	618	125	761	33	19	32	84	176	503	43	722
% App. Total	38.1	3.9	58		2.4	81.2	16.4		39.3	22.6	38.1		24.4	69.7	6	
PHF	.865	.813	.871	.955	.750	.893	.845	.915	.750	.594	.889	1.000	.830	.953	.896	.940
Cars	128	13	195	336	18	615	125	758	33	19	32	84	176	499	43	718
% Cars	100	100	100	100	100	99.5	100	99.6	100	100	100	100	100	99.2	100	99.4
Trucks	0	0	0	0	0	3	0	3	0	0	0	0	0	4	0	4

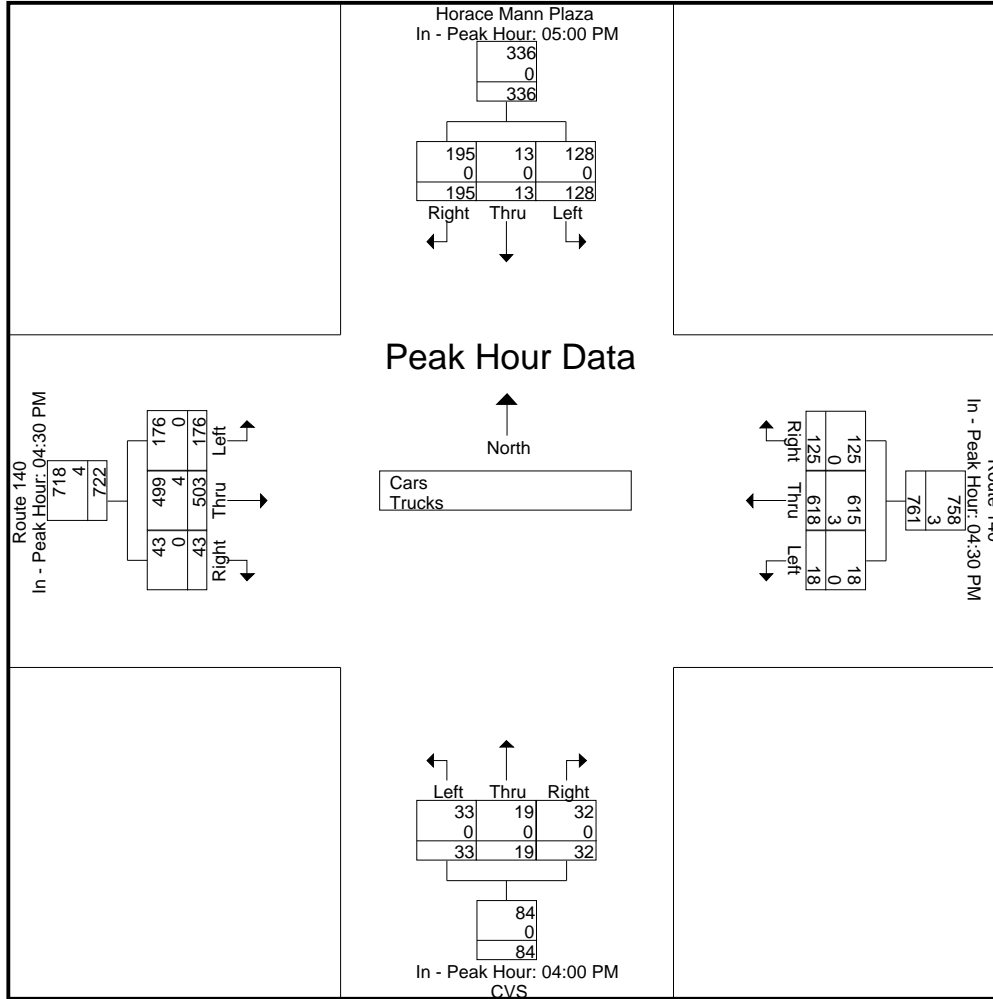

Accurate Counts

978-664-2565

N/S Street : Horace Mann Plaza / CVS
 E/W Street : Route 140
 City/State : Franklin, MA
 Weather : Clear

File Name : 66410002
 Site Code : 66410002
 Start Date : 3/5/2020
 Page No : 4

Groups Printed- Cars

Start Time	Horace Mann Plaza From North			Route 140 From East			CVS From South			Route 140 From West			Int. Total
	Left	Thru	Right	Left	Thru	Right	Left	Thru	Right	Left	Thru	Right	
04:00 PM	23	3	51	9	154	29	8	4	9	24	100	12	426
04:15 PM	24	4	48	3	150	29	9	4	8	30	109	10	428
04:30 PM	23	4	47	5	131	27	11	3	7	29	120	11	418
04:45 PM	30	4	49	6	155	28	5	8	8	53	128	11	485
Total	100	15	195	23	590	113	33	19	32	136	457	44	1757
05:00 PM	32	3	47	2	172	33	9	3	6	53	121	9	490
05:15 PM	31	4	45	5	157	37	7	3	10	41	130	12	482
05:30 PM	28	2	56	4	126	26	11	5	4	37	100	14	413
05:45 PM	37	4	47	3	97	24	4	6	11	37	114	11	395
Total	128	13	195	14	552	120	31	17	31	168	465	46	1780
Grand Total	228	28	390	37	1142	233	64	36	63	304	922	90	3537
Apprch %	35.3	4.3	60.4	2.6	80.9	16.5	39.3	22.1	38.7	23.1	70.1	6.8	
Total %	6.4	0.8	11	1	32.3	6.6	1.8	1	1.8	8.6	26.1	2.5	

Start Time	Horace Mann Plaza From North				Route 140 From East				CVS From South				Route 140 From West				Int. Total
	Left	Thru	Right	App. Total	Left	Thru	Right	App. Total	Left	Thru	Right	App. Total	Left	Thru	Right	App. Total	
Peak Hour Analysis From 04:00 PM to 05:45 PM - Peak 1 of 1																	
Peak Hour for Entire Intersection Begins at 04:30 PM																	
04:30 PM	23	4	47	74	5	131	27	163	11	3	7	21	29	120	11	160	418
04:45 PM	30	4	49	83	6	155	28	189	5	8	8	21	53	128	11	192	485
05:00 PM	32	3	47	82	2	172	33	207	9	3	6	18	53	121	9	183	490
05:15 PM	31	4	45	80	5	157	37	199	7	3	10	20	41	130	12	183	482
Total Volume	116	15	188	319	18	615	125	758	32	17	31	80	176	499	43	718	1875
% App. Total	36.4	4.7	58.9		2.4	81.1	16.5		40	21.2	38.8		24.5	69.5	6		
PHF	.906	.938	.959	.961	.750	.894	.845	.915	.727	.531	.775	.952	.830	.960	.896	.935	.957

Accurate Counts

978-664-2565

File Name : 66410002

Site Code : 66410002

Start Date : 3/5/2020

Page No : 5

N/S Street : Horace Mann Plaza / CVS

E/W Street : Route 140

City/State : Franklin, MA

Weather : Clear

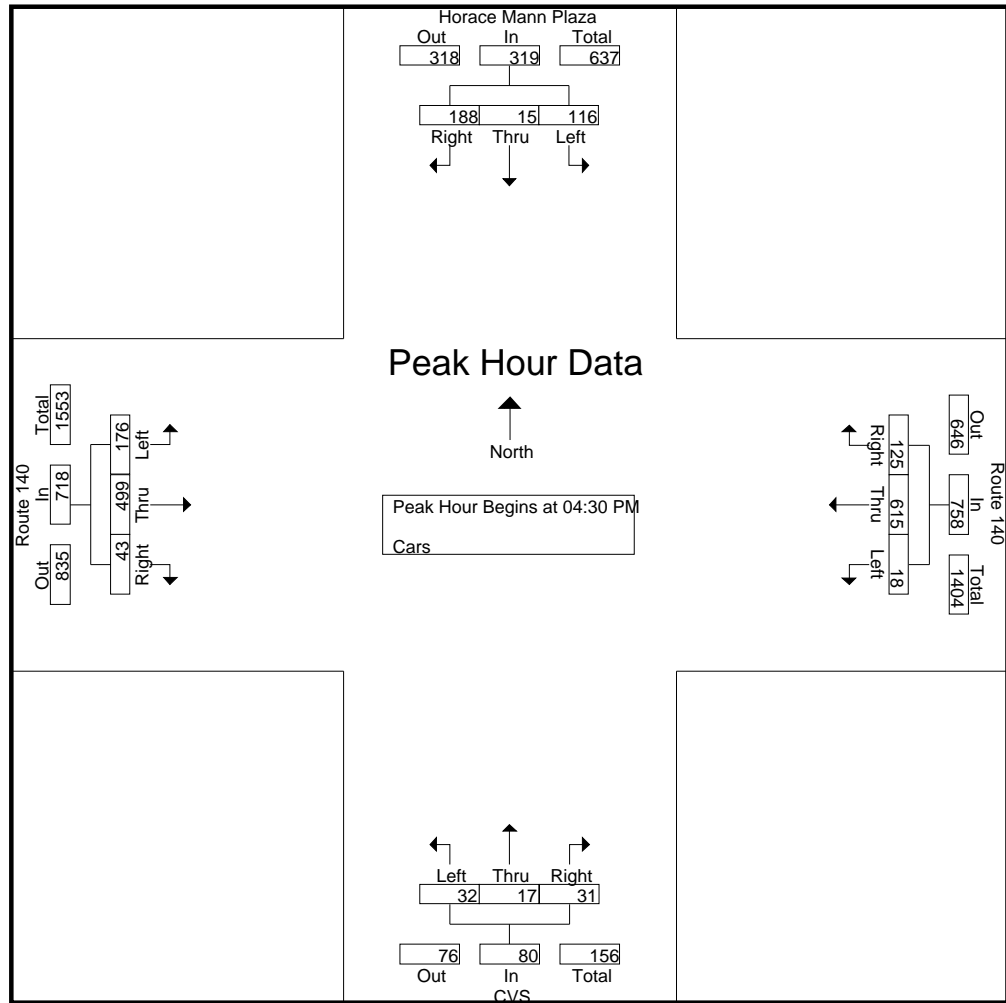

Peak Hour Analysis From 04:00 PM to 05:45 PM - Peak 1 of 1

Peak Hour for Each Approach Begins at:

	05:00 PM				04:30 PM				04:00 PM				04:30 PM			
+0 mins.	32	3	47	82	5	131	27	163	8	4	9	21	29	120	11	160
+15 mins.	31	4	45	80	6	155	28	189	9	4	8	21	53	128	11	192
+30 mins.	28	2	56	86	2	172	33	207	11	3	7	21	53	121	9	183
+45 mins.	37	4	47	88	5	157	37	199	5	8	8	21	41	130	12	183
Total Volume	128	13	195	336	18	615	125	758	33	19	32	84	176	499	43	718
% App. Total	38.1	3.9	58		2.4	81.1	16.5		39.3	22.6	38.1		24.5	69.5	6	
PHF	.865	.813	.871	.955	.750	.894	.845	.915	.750	.594	.889	1.000	.830	.960	.896	.935

Accurate Counts
978-664-2565

File Name : 66410002
Site Code : 66410002
Start Date : 3/5/2020
Page No : 6

N/S Street : Horace Mann Plaza / CVS
E/W Street : Route 140
City/State : Franklin, MA
Weather : Clear

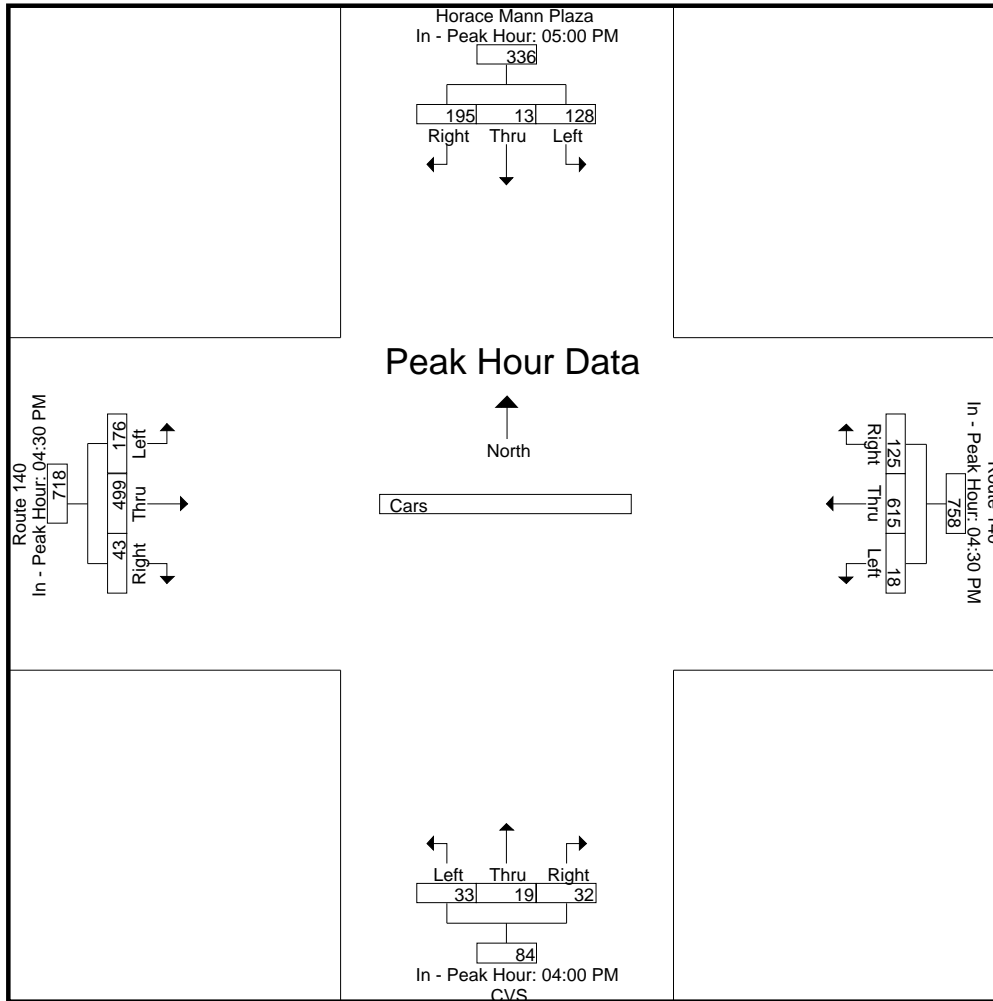

Accurate Counts

978-664-2565

N/S Street : Horace Mann Plaza / CVS
 E/W Street : Route 140
 City/State : Franklin, MA
 Weather : Clear

File Name : 66410002
 Site Code : 66410002
 Start Date : 3/5/2020
 Page No : 7

Groups Printed- Trucks

Start Time	Horace Mann Plaza From North			Route 140 From East			CVS From South			Route 140 From West			Int. Total
	Left	Thru	Right	Left	Thru	Right	Left	Thru	Right	Left	Thru	Right	
04:00 PM	1	0	0	0	2	0	0	0	0	0	0	0	3
04:15 PM	0	0	0	0	1	0	0	0	0	0	1	0	2
04:30 PM	0	0	0	0	2	0	0	0	0	0	1	0	3
04:45 PM	0	0	0	0	0	0	0	0	0	0	0	0	0
Total	1	0	0	0	5	0	0	0	0	0	2	0	8
05:00 PM	0	0	0	0	1	0	0	0	0	0	1	0	2
05:15 PM	0	0	0	0	0	0	0	0	0	0	2	0	2
05:30 PM	0	0	0	0	0	0	0	0	0	0	0	0	0
05:45 PM	0	0	0	0	1	0	0	0	0	0	2	0	3
Total	0	0	0	0	2	0	0	0	0	0	5	0	7
Grand Total	1	0	0	0	7	0	0	0	0	0	7	0	15
Apprch %	100	0	0	0	100	0	0	0	0	0	100	0	
Total %	6.7	0	0	0	46.7	0	0	0	0	0	46.7	0	

Start Time	Horace Mann Plaza From North				Route 140 From East				CVS From South				Route 140 From West				Int. Total
	Left	Thru	Right	App. Total	Left	Thru	Right	App. Total	Left	Thru	Right	App. Total	Left	Thru	Right	App. Total	
Peak Hour Analysis From 04:00 PM to 05:45 PM - Peak 1 of 1																	
Peak Hour for Entire Intersection Begins at 04:00 PM																	
04:00 PM	1	0	0	1	0	2	0	2	0	0	0	0	0	0	0	0	3
04:15 PM	0	0	0	0	0	1	0	1	0	0	0	0	0	1	0	1	2
04:30 PM	0	0	0	0	0	2	0	2	0	0	0	0	0	1	0	1	3
04:45 PM	0	0	0	0	0	0	0	0	0	0	0	0	0	0	0	0	0
Total Volume	1	0	0	1	0	5	0	5	0	0	0	0	0	2	0	2	8
% App. Total	100	0	0	100	0	100	0	100	0	0	0	0	0	100	0	100	100
PHF	.250	.000	.000	.250	.000	.625	.000	.625	.000	.000	.000	.000	.000	.500	.000	.500	.667

Accurate Counts

978-664-2565

File Name : 66410002

Site Code : 66410002

Start Date : 3/5/2020

Page No : 8

N/S Street : Horace Mann Plaza / CVS

E/W Street : Route 140

City/State : Franklin, MA

Weather : Clear

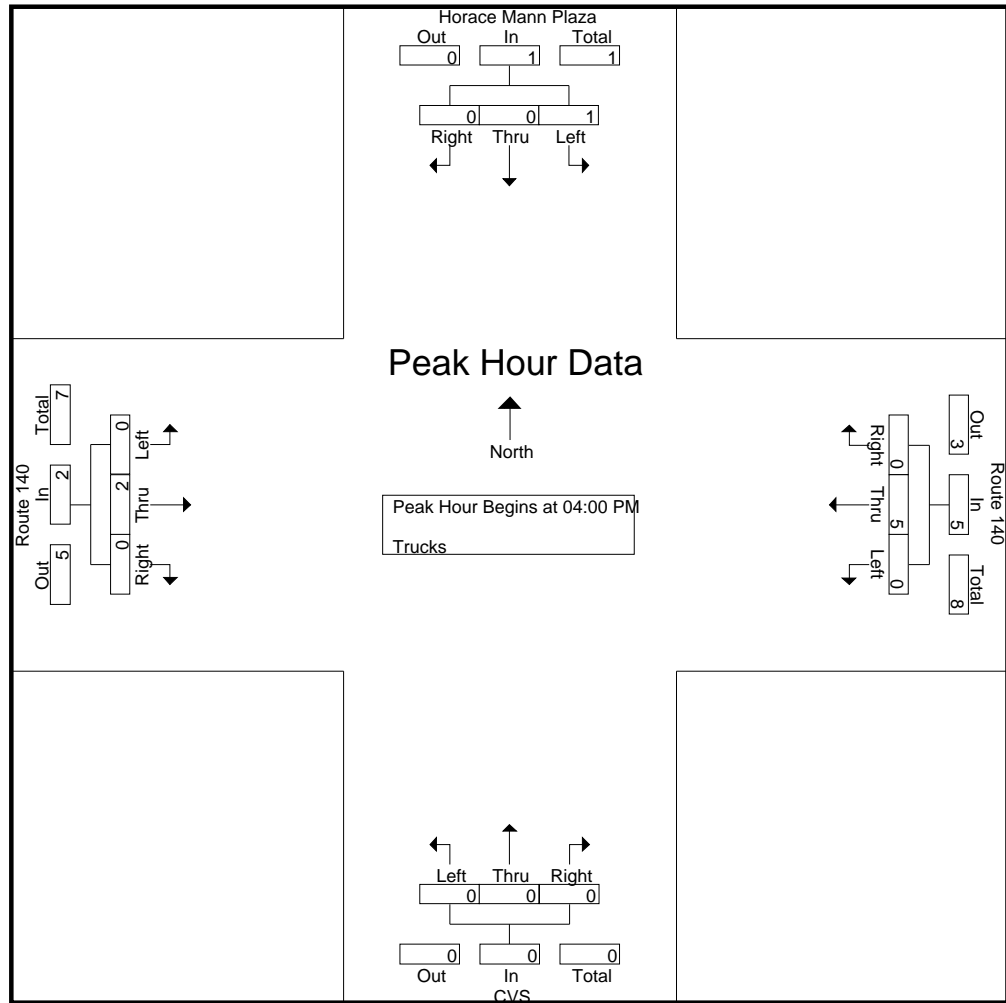

Peak Hour Analysis From 04:00 PM to 05:45 PM - Peak 1 of 1

Peak Hour for Each Approach Begins at:

	04:00 PM				04:00 PM				04:00 PM				05:00 PM			
+0 mins.	1	0	0	1	0	2	0	2	0	0	0	0	0	1	0	1
+15 mins.	0	0	0	0	0	1	0	1	0	0	0	0	0	2	0	2
+30 mins.	0	0	0	0	0	2	0	2	0	0	0	0	0	0	0	0
+45 mins.	0	0	0	0	0	0	0	0	0	0	0	0	0	2	0	2
Total Volume	1	0	0	1	0	5	0	5	0	0	0	0	0	5	0	5
% App. Total	100	0	0		0	100	0		0	0	0		0	100	0	
PHF	.250	.000	.000	.250	.000	.625	.000	.625	.000	.000	.000	.000	.000	.625	.000	.625

Accurate Counts
978-664-2565

File Name : 66410002
Site Code : 66410002
Start Date : 3/5/2020
Page No : 9

N/S Street : Horace Mann Plaza / CVS
E/W Street : Route 140
City/State : Franklin, MA
Weather : Clear

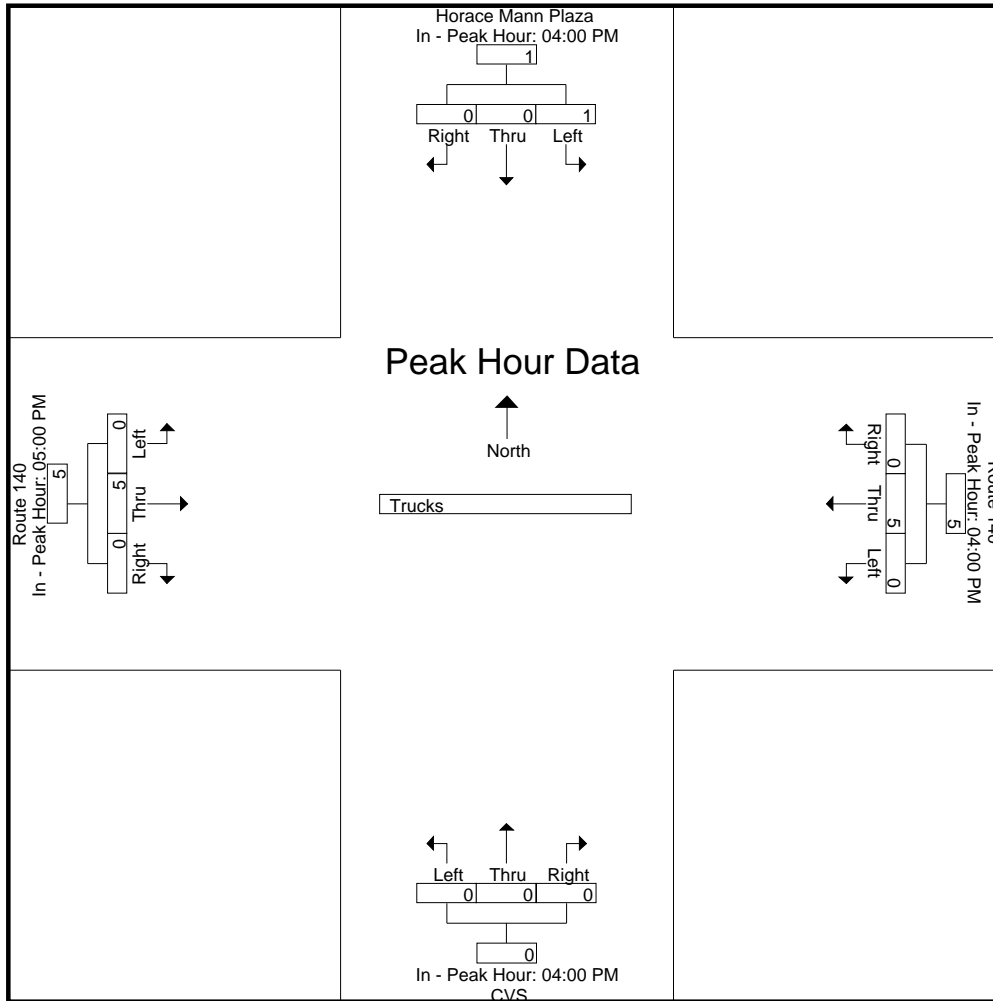

Accurate Counts

978-664-2565

File Name : 66410002

Site Code : 66410002

Start Date : 3/5/2020

Page No : 10

N/S Street : Horace Mann Plaza / CVS

E/W Street : Route 140

City/State : Franklin, MA

Weather : Clear

Groups Printed- Bikes Peds

Start Time	Horace Mann Plaza From North				Route 140 From East				CVS From South				Route 140 From West				Exclu. Total	Inclu. Total	Int. Total
	Left	Thru	Right	Peds	Left	Thru	Right	Peds	Left	Thru	Right	Peds	Left	Thru	Right	Peds			
04:00 PM	0	0	0	1	0	0	0	2	0	0	0	0	0	0	0	0	3	0	3
04:15 PM	0	0	0	5	0	0	0	2	0	0	0	0	0	0	0	0	7	0	7
04:30 PM	0	0	0	0	0	1	0	2	0	0	0	0	0	0	0	0	2	1	3
04:45 PM	0	0	0	6	0	1	0	0	0	0	0	0	0	0	0	1	7	1	8
Total	0	0	0	12	0	2	0	6	0	0	0	0	0	0	0	1	19	2	21
05:00 PM	0	0	0	1	0	1	0	0	0	0	0	0	0	1	3	0	1	5	6
05:15 PM	0	0	0	0	0	1	0	1	0	4	0	1	0	0	0	0	2	5	7
05:30 PM	0	0	0	1	0	3	0	1	0	0	0	1	0	0	0	0	3	3	6
05:45 PM	0	0	0	0	0	1	0	0	0	0	0	0	0	0	0	0	0	1	1
Total	0	0	0	2	0	6	0	2	0	4	0	2	0	1	3	0	6	14	20
Grand Total	0	0	0	14	0	8	0	8	0	4	0	2	0	1	3	1	25	16	41
Apprch %	0	0	0		0	100	0		0	100	0		0	25	75				
Total %	0	0	0		0	50	0		0	25	0		0	6.2	18.8		61	39	

Start Time	Horace Mann Plaza From North				Route 140 From East				CVS From South				Route 140 From West				Int. Total	
	Left	Thru	Right	App. Total	Left	Thru	Right	App. Total	Left	Thru	Right	App. Total	Left	Thru	Right	App. Total		
Peak Hour Analysis From 04:00 PM to 05:45 PM - Peak 1 of 1																		
Peak Hour for Entire Intersection Begins at 04:45 PM																		
04:45 PM	0	0	0	0	0	1	0	1	0	0	0	0	0	0	0	0	0	1
05:00 PM	0	0	0	0	0	1	0	1	0	0	0	0	0	1	3	4	4	5
05:15 PM	0	0	0	0	0	1	0	1	0	4	0	4	0	0	0	0	0	5
05:30 PM	0	0	0	0	0	3	0	3	0	0	0	0	0	0	0	0	0	3
Total Volume	0	0	0	0	0	6	0	6	0	4	0	4	0	1	3	4	4	14
% App. Total	0	0	0		0	100	0		0	100	0		0	25	75			
PHF	.000	.000	.000	.000	.000	.500	.000	.500	.000	.250	.000	.250	.000	.250	.250	.250	.250	.700

Accurate Counts
978-664-2565

File Name : 66410002
Site Code : 66410002
Start Date : 3/5/2020
Page No : 11

N/S Street : Horace Mann Plaza / CVS
E/W Street : Route 140
City/State : Franklin, MA
Weather : Clear

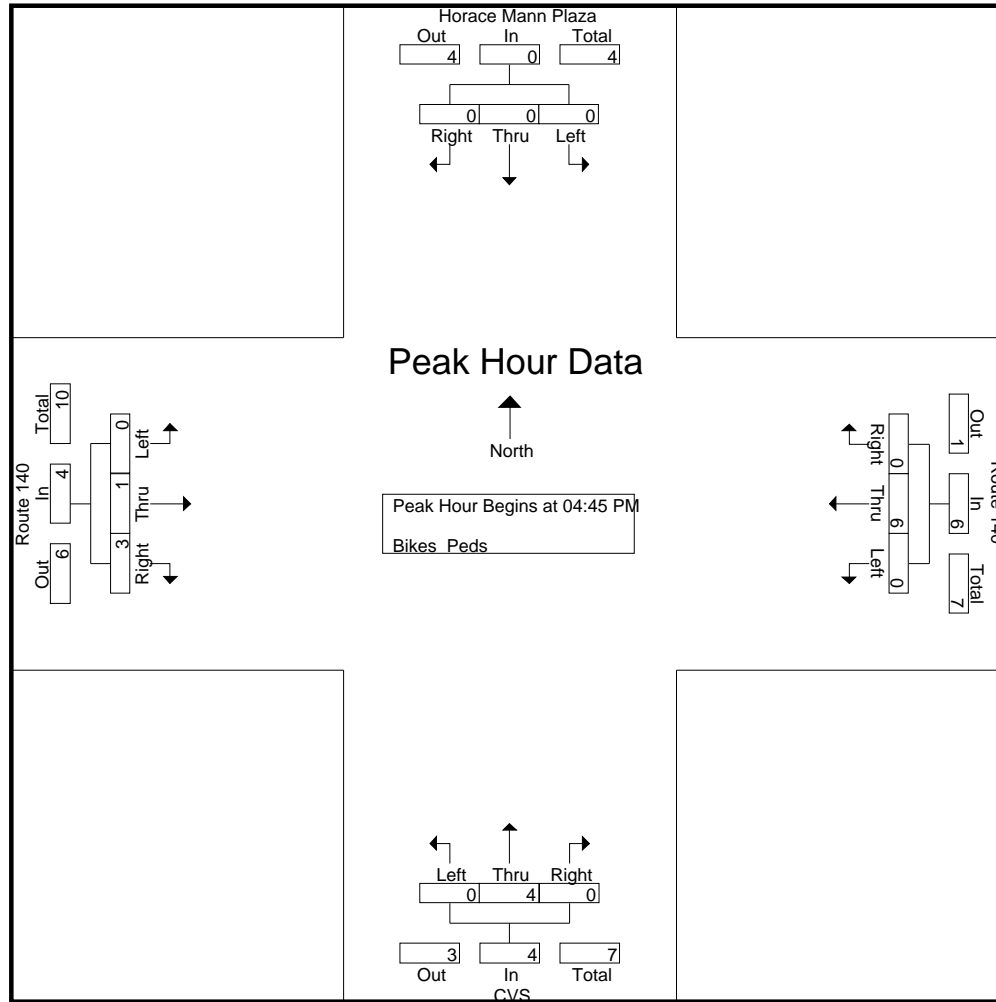

Peak Hour Analysis From 04:00 PM to 05:45 PM - Peak 1 of 1
Peak Hour for Each Approach Begins at:

	04:00 PM				04:45 PM				04:30 PM				04:15 PM			
+0 mins.	0	0	0	0	0	1	0	1	0	0	0	0	0	0	0	0
+15 mins.	0	0	0	0	0	1	0	1	0	0	0	0	0	0	0	0
+30 mins.	0	0	0	0	0	1	0	1	0	0	0	0	0	0	0	0
+45 mins.	0	0	0	0	0	3	0	3	0	4	0	4	0	1	3	4
Total Volume	0	0	0	0	0	6	0	6	0	4	0	4	0	1	3	4
% App. Total	0	0	0	0	0	100	0	100	0	100	0	100	0	25	75	100
PHF	.000	.000	.000	.000	.000	.500	.000	.500	.000	.250	.000	.250	.000	.250	.250	.250

Accurate Counts
978-664-2565

File Name : 66410002
Site Code : 66410002
Start Date : 3/5/2020
Page No : 12

N/S Street : Horace Mann Plaza / CVS
E/W Street : Route 140
City/State : Franklin, MA
Weather : Clear

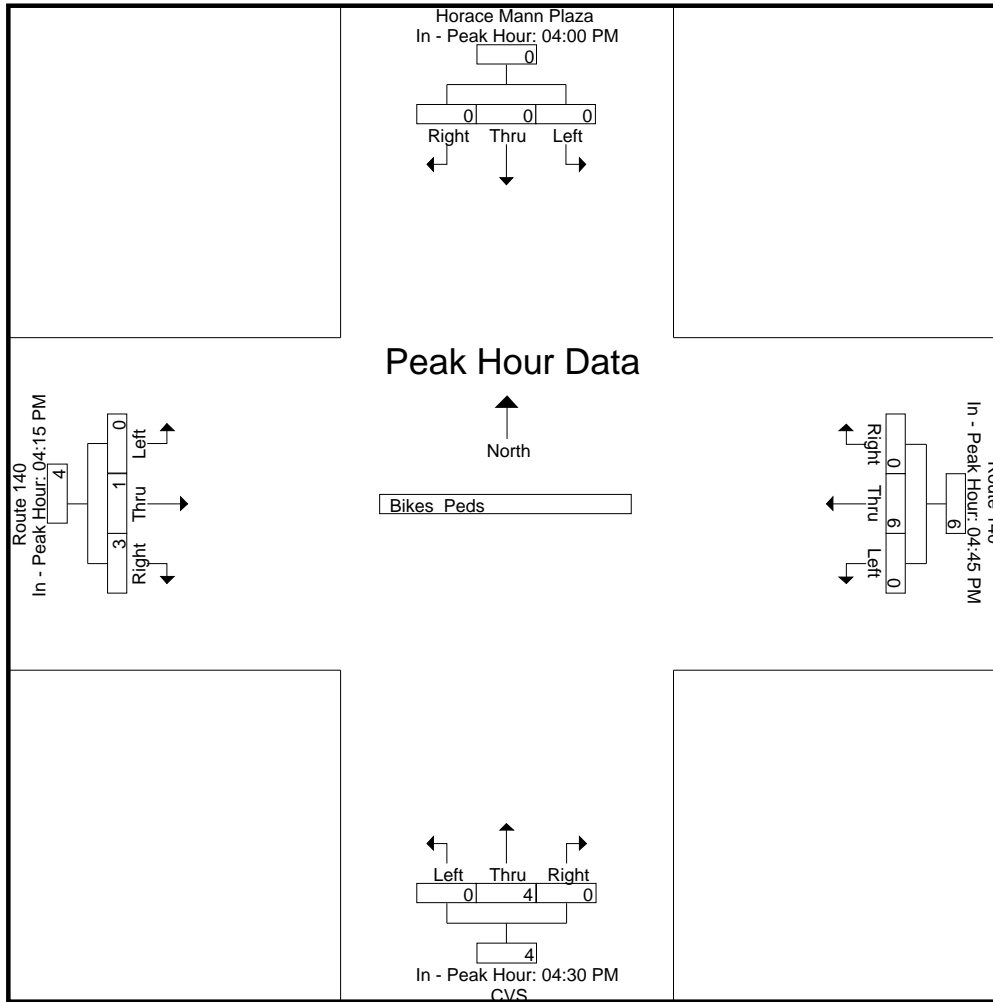

SEASONAL ADJUSTMENT DATA



Traffic Pattern by Month for 1/1/2017 - 12/31/2017

Factor Group	Station	Weight	Jan	Feb	Mar	Apr	May	Jun	Jul	Aug	Sep	Oct	Nov	Dec
U1-Boston		0	0.756	0.867	0.927	0.962	1.042	1.097	1.062	1.149	1.073	1.048	1.000	0.918
Average of Weighted Factors			0.000	0.000	0.000	0.000	0.000	0.000	0.000	0.000	0.000	0.000	0.000	0.000

Traffic Pattern by Month for 1/1/2017 - 12/31/2017

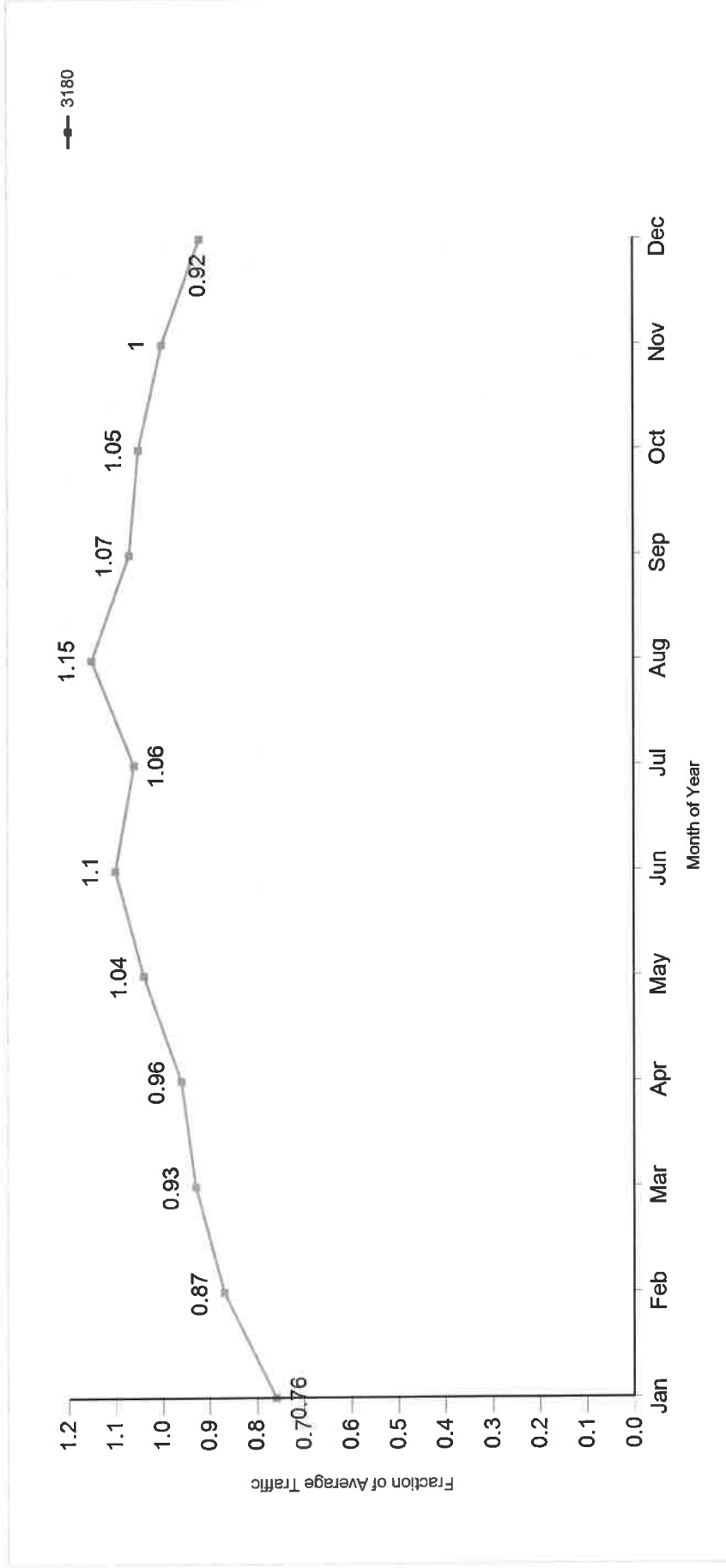

VEHICLE TRAVEL SPEED DATA



Location : East Central Street
 Location : West of Lewis Street
 City/State: Franklin, MA
 Direction: EB,

92170001

1/4/2022	0 - 15	> 15 -	> 20 -	> 25 -	> 30 -	> 35 -	> 40 -	> 45 -	> 50 -	> 55 -	> 60 -	> 65 -	> 70	Total
Time	MPH	20 MPH	25 MPH	30 MPH	35 MPH	40 MPH	45 MPH	50 MPH	55 MPH	60 MPH	65 MPH	70 MPH	MPH	
12:00 AM	0	0	0	4	8	4	0	0	0	0	0	0	0	16
1:00	0	0	0	1	6	2	0	0	0	0	0	0	0	9
2:00	0	0	0	3	3	5	1	0	0	0	0	0	0	12
3:00	0	0	0	4	4	9	0	0	0	0	0	0	0	17
4:00	0	0	0	2	9	14	0	0	0	0	0	0	0	25
5:00	0	0	3	13	43	28	11	1	0	0	0	0	0	99
6:00	1	0	4	48	116	51	10	0	0	1	0	0	0	231
7:00	0	7	36	156	231	51	8	1	0	0	0	0	0	490
8:00	5	4	33	182	278	67	1	0	0	0	0	0	0	570
9:00	2	13	39	202	175	58	4	1	1	0	0	0	0	495
10:00	0	4	39	201	242	35	3	0	0	0	0	0	0	524
11:00	10	27	56	222	207	42	2	1	0	0	0	0	0	567
12:00 PM	9	23	62	201	256	63	3	1	0	0	0	0	0	618
1:00	4	20	72	271	221	50	5	1	0	0	0	0	0	644
2:00	13	22	99	335	182	40	0	0	0	0	0	0	0	691
3:00	9	21	90	340	213	39	2	0	0	0	0	0	0	714
4:00	3	13	122	279	188	29	3	0	0	0	0	0	0	637
5:00	0	7	112	298	154	23	7	0	0	0	0	0	0	601
6:00	1	0	32	182	186	39	3	0	0	0	0	0	0	443
7:00	0	2	22	88	128	44	4	1	0	0	0	0	0	289
8:00	0	2	6	46	97	30	2	0	0	0	0	0	0	183
9:00	0	3	3	22	67	33	3	1	1	0	0	0	0	133
10:00	0	1	0	8	31	18	1	0	0	0	0	0	0	59
11:00	0	0	0	8	19	7	4	1	0	0	0	0	0	39
Total	57	169	830	3116	3064	781	77	9	2	1	0	0	0	8106

Percentile	15th	50th	85th	95th
Speed	25.4	29.7	34.1	36.6
Mean Speed (Average)	29.7			
10 MPH Pace Speed	25-34			
Number in Pace	6135			
Percent in Pace	75.7%			
Number > 30 MPH	3934			
Percent > 30 MPH	48.5%			

Location : East Central Street
 Location : West of Lewis Street
 City/State: Franklin, MA
 Direction: WB,

92170001

1/4/2022	0 - 15	> 15 -	> 20 -	> 25 -	> 30 -	> 35 -	> 40 -	> 45 -	> 50 -	> 55 -	> 60 -	> 65 -	> 70	Total
Time	MPH	20 MPH	25 MPH	30 MPH	35 MPH	40 MPH	45 MPH	50 MPH	55 MPH	60 MPH	65 MPH	70 MPH	MPH	
12:00 AM	0	0	1	2	12	9	6	0	0	0	0	0	0	30
1:00	0	0	0	0	4	5	2	0	0	0	0	0	0	11
2:00	0	0	0	1	4	2	1	0	0	0	0	0	0	8
3:00	0	0	1	3	6	5	1	0	0	0	0	0	0	16
4:00	0	1	2	0	11	8	1	1	0	0	0	0	0	24
5:00	0	2	2	4	17	34	11	2	0	0	0	1	0	73
6:00	3	17	26	46	71	57	11	3	0	0	0	1	1	236
7:00	0	23	54	110	147	67	3	1	0	0	0	1	1	407
8:00	2	24	77	165	166	51	4	0	0	2	0	0	3	494
9:00	2	17	55	132	176	63	2	0	1	0	1	0	3	452
10:00	0	9	75	191	190	60	3	1	0	0	0	0	0	529
11:00	2	20	94	225	189	36	3	0	0	0	0	0	0	569
12:00 PM	5	30	96	243	230	62	8	0	0	0	0	0	0	674
1:00	9	34	91	264	213	55	8	1	0	0	0	0	0	675
2:00	23	47	153	326	157	35	4	0	0	0	0	0	0	745
3:00	13	66	168	313	175	27	1	0	0	0	0	0	0	763
4:00	14	54	188	321	166	14	1	1	0	0	1	0	0	760
5:00	4	41	180	277	195	27	3	0	0	0	1	0	0	728
6:00	1	15	61	182	207	41	4	0	0	0	0	0	0	511
7:00	1	2	16	106	137	61	9	2	0	1	0	0	3	338
8:00	0	0	6	48	106	46	11	1	0	0	0	0	0	218
9:00	0	0	5	17	61	36	8	1	0	0	0	0	1	129
10:00	0	0	0	15	28	24	8	2	0	0	0	0	0	77
11:00	0	0	0	2	15	20	10	0	0	0	0	0	0	47
Total	79	402	1351	2993	2683	845	123	16	1	3	3	3	12	8514

Percentile	15th	50th	85th	95th
Speed	23.5	29.1	34.1	37.2
Mean Speed (Average)	29.1			
10 MPH Pace Speed	25-34			
Number in Pace	5649			
Percent in Pace	66.3%			
Number > 30 MPH	3689			
Percent > 30 MPH	43.3%			

Location : East Central Street
 Location : West of Lewis Street
 City/State: Franklin, MA
 Direction: WB,

92170001

1/5/2022	0 - 15	> 15 -	> 20 -	> 25 -	> 30 -	> 35 -	> 40 -	> 45 -	> 50 -	> 55 -	> 60 -	> 65 -	> 70	Total
Time	MPH	20 MPH	25 MPH	30 MPH	35 MPH	40 MPH	45 MPH	50 MPH	55 MPH	60 MPH	65 MPH	70 MPH	MPH	
12:00 AM	0	0	1	2	5	10	0	0	0	0	0	0	0	18
1:00	0	0	0	2	5	2	1	0	0	0	0	0	0	10
2:00	0	0	0	1	1	4	3	0	0	0	0	0	0	9
3:00	0	0	1	0	3	0	0	0	0	0	0	0	0	4
4:00	0	0	2	3	5	6	2	4	0	0	0	0	0	22
5:00	1	4	5	5	26	26	8	2	0	0	0	0	1	78
6:00	0	4	38	36	76	47	13	2	0	0	0	0	0	216
7:00	1	20	50	116	146	58	2	0	0	0	0	0	1	394
8:00	8	33	44	163	171	51	3	2	2	1	0	1	2	481
9:00	1	14	36	145	189	57	6	0	0	0	0	0	0	448
10:00	18	38	122	173	130	30	3	0	0	0	0	1	0	515
11:00	5	24	90	256	169	51	4	0	0	1	0	0	0	600
12:00 PM	18	43	174	251	179	35	2	0	0	0	0	0	0	702
1:00	5	17	106	313	172	39	6	1	0	0	0	0	0	659
2:00	8	36	173	286	144	32	4	0	0	0	0	0	0	683
3:00	6	42	188	279	185	28	1	0	0	0	0	0	0	729
4:00	33	64	203	278	132	15	2	0	1	0	0	0	0	728
5:00	2	7	122	319	175	36	1	0	0	1	0	0	0	663
6:00	0	10	52	183	193	73	1	1	0	0	0	2	0	515
7:00	0	1	23	109	153	63	7	0	0	0	0	0	0	356
8:00	1	0	10	59	99	52	7	0	0	0	0	0	0	228
9:00	0	0	3	24	72	45	12	1	0	0	0	0	0	157
10:00	0	0	7	16	25	27	2	0	0	0	0	0	0	77
11:00	0	0	1	14	19	14	2	0	0	0	0	0	0	50
Total	107	357	1451	3033	2474	801	92	13	3	3	0	4	4	8342

Percentile	15th	50th	85th	95th
Speed	23.5	29.1	34.1	36.6
Mean Speed (Average)	28.7			
10 MPH Pace Speed	25-34			
Number in Pace	5487			
Percent in Pace	65.8%			
Number > 30 MPH	3394			
Percent > 30 MPH	40.7%			

Grand Total	186	759	2802	6026	5157	1646	215	29	4	6	3	7	16	16856
Stats	Percentile				15th	50th	85th	95th						
	Speed				23.5	29.1	34.1	37.2						
	Mean Speed (Average)				29.0									
	10 MPH Pace Speed				25-34									
	Number in Pace				11178									
	Percent in Pace				66.0%									
	Number > 30 MPH				7159									
	Percent > 30 MPH				42.3%									

Location : East Central Street
 Location : West of Lewis Street
 City/State: Franklin, MA
 Direction: Combined

92170001

1/4/2022	0 - 15	> 15 -	> 20 -	> 25 -	> 30 -	> 35 -	> 40 -	> 45 -	> 50 -	> 55 -	> 60 -	> 65 -	> 70	Total
Time	MPH	20 MPH	25 MPH	30 MPH	35 MPH	40 MPH	45 MPH	50 MPH	55 MPH	60 MPH	65 MPH	70 MPH	MPH	
12:00 AM	0	0	1	6	20	13	6	0	0	0	0	0	0	46
1:00	0	0	0	1	10	7	2	0	0	0	0	0	0	20
2:00	0	0	0	4	7	7	2	0	0	0	0	0	0	20
3:00	0	0	1	7	10	14	1	0	0	0	0	0	0	33
4:00	0	1	2	2	20	22	1	1	0	0	0	0	0	49
5:00	0	2	5	17	60	62	22	3	0	0	0	1	0	172
6:00	4	17	30	94	187	108	21	3	0	1	0	1	1	467
7:00	0	30	90	266	378	118	11	2	0	0	0	1	1	897
8:00	7	28	110	347	444	118	5	0	0	2	0	0	3	1064
9:00	4	30	94	334	351	121	6	1	2	0	1	0	3	947
10:00	0	13	114	392	432	95	6	1	0	0	0	0	0	1053
11:00	12	47	150	447	396	78	5	1	0	0	0	0	0	1136
12:00 PM	14	53	158	444	486	125	11	1	0	0	0	0	0	1292
1:00	13	54	163	535	434	105	13	2	0	0	0	0	0	1319
2:00	36	69	252	661	339	75	4	0	0	0	0	0	0	1436
3:00	22	87	258	653	388	66	3	0	0	0	0	0	0	1477
4:00	17	67	310	600	354	43	4	1	0	0	1	0	0	1397
5:00	4	48	292	575	349	50	10	0	0	0	1	0	0	1329
6:00	2	15	93	364	393	80	7	0	0	0	0	0	0	954
7:00	1	4	38	194	265	105	13	3	0	1	0	0	3	627
8:00	0	2	12	94	203	76	13	1	0	0	0	0	0	401
9:00	0	3	8	39	128	69	11	2	1	0	0	0	1	262
10:00	0	1	0	23	59	42	9	2	0	0	0	0	0	136
11:00	0	0	0	10	34	27	14	1	0	0	0	0	0	86
Total	136	571	2181	6109	5747	1626	200	25	3	4	3	3	12	16620

Percentile	15th	50th	85th	95th
Speed	24.8	29.7	34.1	36.6
Mean Speed (Average)	29.4			
10 MPH Pace Speed	25-34			
Number in Pace	11785			
Percent in Pace	70.9%			
Number > 30 MPH	7623			
Percent > 30 MPH	45.9%			

Location : East Central Street
 Location : West of Lewis Street
 City/State: Franklin, MA
 Direction: Combined

92170001

1/5/2022	0 - 15	> 15 -	> 20 -	> 25 -	> 30 -	> 35 -	> 40 -	> 45 -	> 50 -	> 55 -	> 60 -	> 65 -	> 70	Total
Time	MPH	20 MPH	25 MPH	30 MPH	35 MPH	40 MPH	45 MPH	50 MPH	55 MPH	60 MPH	65 MPH	70 MPH	MPH	
12:00 AM	0	0	1	5	8	18	0	0	0	0	0	0	0	32
1:00	0	0	0	4	8	3	2	0	0	0	0	0	0	17
2:00	0	0	0	2	6	8	3	0	0	0	0	0	0	19
3:00	0	0	1	0	10	3	1	0	0	0	0	0	0	15
4:00	1	0	5	5	15	14	4	4	0	0	0	0	0	48
5:00	2	4	7	28	61	56	12	2	0	0	0	0	1	173
6:00	0	4	56	105	196	79	17	2	1	0	0	0	0	460
7:00	1	25	95	342	335	96	6	0	0	0	0	0	1	901
8:00	11	38	115	353	385	89	8	2	2	1	0	1	2	1007
9:00	5	29	91	337	378	91	9	0	0	0	0	0	0	940
10:00	23	46	190	384	314	71	5	0	0	0	0	1	0	1034
11:00	9	37	149	519	383	88	8	0	0	1	0	0	0	1194
12:00 PM	26	73	252	532	379	75	4	0	0	0	0	0	0	1341
1:00	12	31	170	547	366	74	8	1	0	0	0	0	0	1209
2:00	17	61	284	559	323	74	9	0	0	0	0	0	0	1327
3:00	20	77	301	592	366	60	2	0	0	0	0	0	0	1418
4:00	41	76	354	536	272	36	2	0	1	0	0	0	0	1318
5:00	3	12	224	523	371	53	1	0	0	1	0	0	0	1188
6:00	0	12	84	377	375	114	1	1	0	0	0	2	0	966
7:00	2	6	49	216	291	95	11	1	0	0	0	0	0	671
8:00	1	1	14	117	200	66	10	1	0	0	0	0	0	410
9:00	0	0	3	44	125	74	17	1	0	0	0	0	0	264
10:00	0	0	8	32	53	48	4	0	0	0	0	0	0	145
11:00	0	0	2	28	35	25	2	0	0	0	0	0	0	92
Total	174	532	2455	6187	5255	1410	146	15	4	3	0	4	4	16189

Percentile	15th	50th	85th	95th
Speed	24.1	29.1	33.5	36.6
Mean Speed (Average)	29.0			
10 MPH Pace Speed	25-34			
Number in Pace	11386			
Percent in Pace	70.3%			
Number > 30 MPH	6841			
Percent > 30 MPH	42.3%			

Grand Total	310	1103	4636	12296	11002	3036	346	40	7	7	3	7	16	32809
Stats														
Percentile				15th	50th	85th	95th							
Speed				24.8	29.7	34.1	36.6							
Mean Speed (Average)				29.2										
10 MPH Pace Speed				25-34										
Number in Pace				23261										
Percent in Pace				70.5%										
Number > 30 MPH				14603										
Percent > 30 MPH				44.3%										

MASSDOT CRASH RATE WORKSHEETS AND HIGH CRASH LOCATION MAPPING



INTERSECTION CRASH RATE WORKSHEET

CITY/TOWN : FRANKLIN COUNT DATE : 3/5/20 (THURSDAY)
 DISTRICT : 3 UNSIGNALIZED : SIGNALIZED : ADJ. TO 2022

~ INTERSECTION DATA ~

MAJOR STREET : EAST CENTRAL ST. (ROUTE 140)
 MINOR STREET(S) : KING ST. / CHESTNUT ST.

**INTERSECTION
 DIAGRAM**
 (Label Approaches)

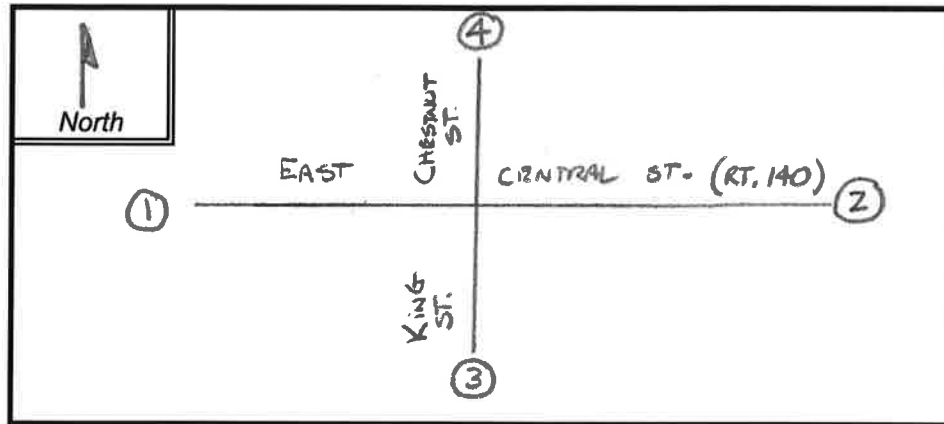

PEAK HOUR VOLUMES

APPROACH :	1	2	3	4	5	Total Peak Hourly Approach Volume
DIRECTION :	EB	WB	NB	SB	—	
PEAK HOURLY VOLUMES (AM/PM) :	614	847	614	461	—	2,536

"K" FACTOR : 0.09 INTERSECTION ADT (V) = TOTAL DAILY APPROACH VOLUME : 28,178

TOTAL # OF CRASHES : 29 # OF YEARS : 5 AVERAGE # OF CRASHES PER YEAR (A) : 5.8

CRASH RATE CALCULATION : 0.56 RATE = $\frac{(A * 1,000,000)}{(V * 365)}$

Comments : CRASH RATE IS BELOW MASSDOT AVERAGE OF 0.78/0.89
 Project Title & Date : 1/18/22

INTERSECTION CRASH RATE WORKSHEET

CITY/TOWN : FRANKLIN COUNT DATE : 3/5/20 (THURSDAY) ADT, TO 2022
 DISTRICT : 3 UNSIGNALIZED : SIGNALIZED :

~ INTERSECTION DATA ~

MAJOR STREET : EAST CENTRAL ST. (ROUTE 140)
 MINOR STREET(S) : HORACE MANN PLAZA / CVS PHARMACY

INTERSECTION DIAGRAM
(Label Approaches)

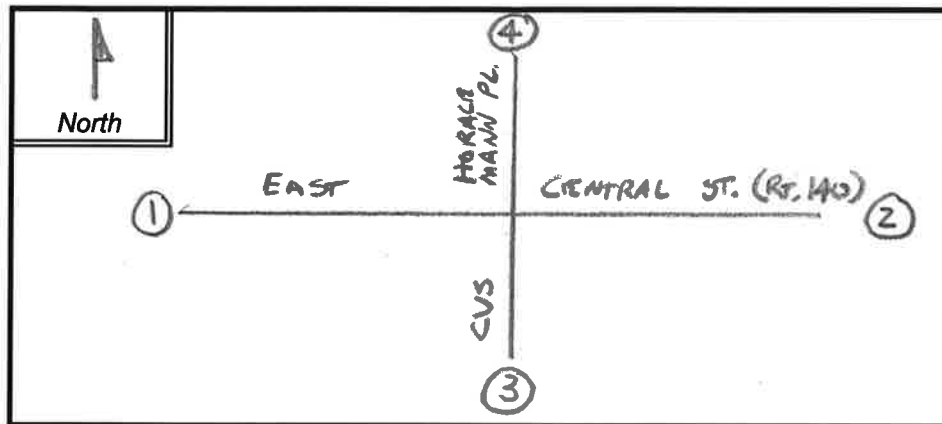

PEAK HOUR VOLUMES

APPROACH :	1	2	3	4	5	Total Peak Hourly Approach Volume
DIRECTION :	EB	WB	NB	SB	-	
PEAK HOURLY VOLUMES (AM/PM) :	788	830	85	347	-	2,050

"K" FACTOR : 0.09 INTERSECTION ADT (V) = TOTAL DAILY APPROACH VOLUME : 22,778

TOTAL # OF CRASHES : 14 # OF YEARS : 25 AVERAGE # OF CRASHES PER YEAR (A) : 2.8

CRASH RATE CALCULATION : 0.34 RATE = $\frac{(A * 1,000,000)}{(V * 365)}$

Comments : CRASH RATE IS BELOW MASSDOT AVERAGE OF 0.78/0.89
 Project Title & Date : 1/18/22

INTERSECTION CRASH RATE WORKSHEET

CITY/TOWN : FRANKLIN COUNT DATE : 3/5/20 (THURSDAY) ADT. TO 2022
 DISTRICT : 3 UNSIGNALIZED : SIGNALIZED :

~ INTERSECTION DATA ~

MAJOR STREET : EAST CENTRAL ST. (ROUTE 140)
 MINOR STREET(S) : 230 EAST CENTRAL ST.

**INTERSECTION
 DIAGRAM**
 (Label Approaches)

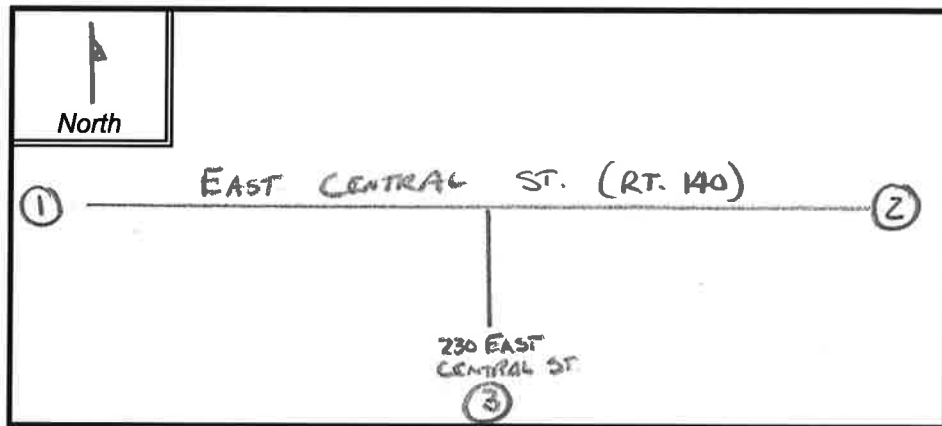

PEAK HOUR VOLUMES

APPROACH :	1	2	3	4	5	Total Peak Hourly Approach Volume
DIRECTION :	EB	WB	NB	-	-	
PEAK HOURLY VOLUMES (AM/PM) :	749	847	0	-	-	1,596

"K" FACTOR : INTERSECTION ADT (V) = TOTAL DAILY APPROACH VOLUME :

TOTAL # OF CRASHES : # OF YEARS : AVERAGE # OF CRASHES PER YEAR (A) :

CRASH RATE CALCULATION : RATE = $\frac{(A * 1,000,000)}{(V * 365)}$

Comments : CRASH RATE IS BELOW MASSDOT AVERAGE OF 0.57/0.61
 Project Title & Date: 1/18/22

MassDOT Top Crash Locations

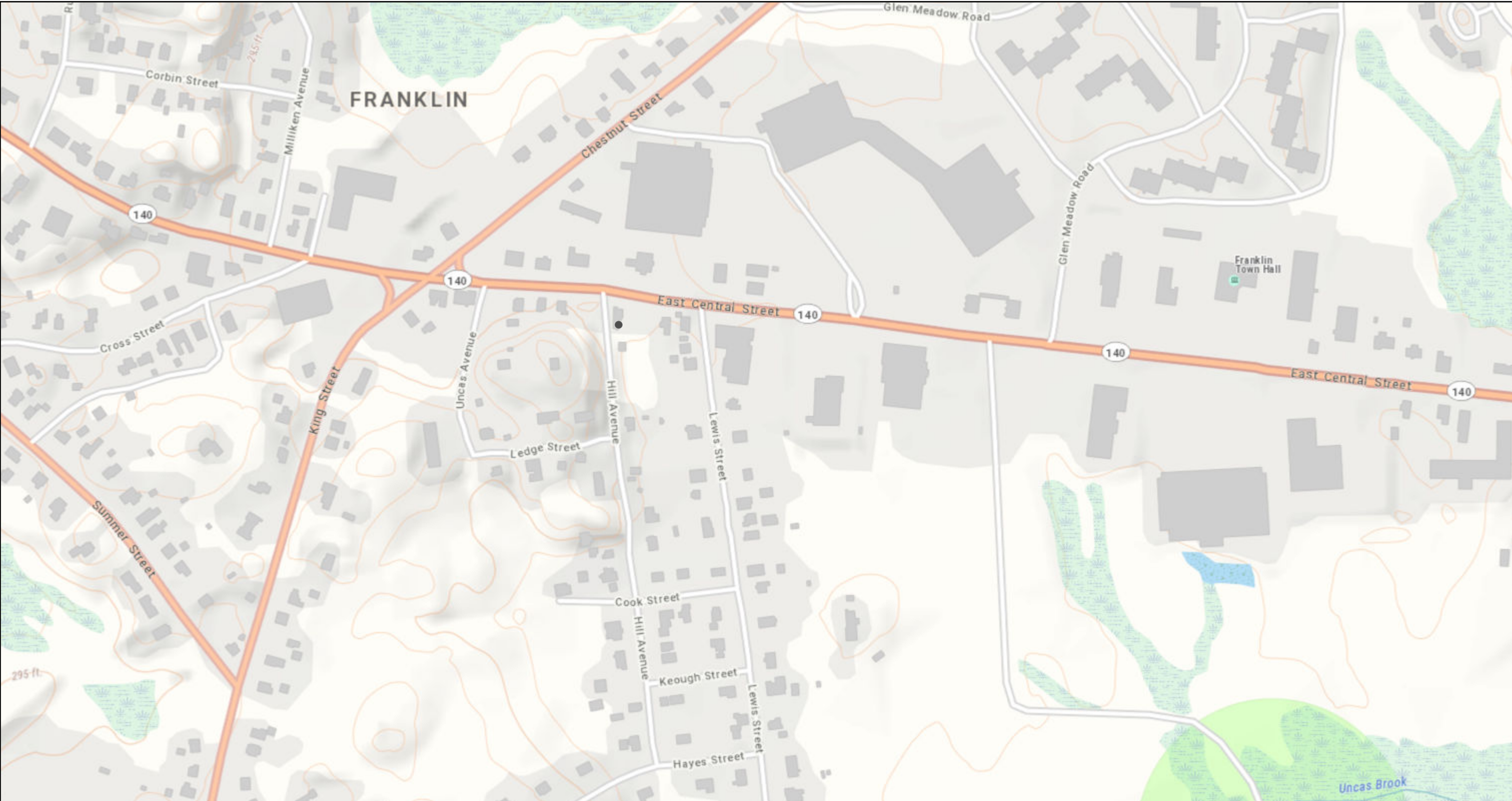

1/17/2022, 3:32:20 PM

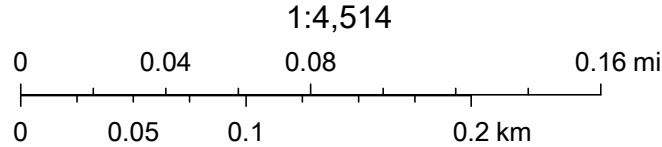

MassGIS

MassDOT Crash Data for Route 140 at Horace Mann Plaza and CVS Pharmacy

Crash Number	Crash Date	Day	Crash Severity	Crash Time	Light Conditions	Manner of Collision	Vehicle Actions Prior to Crash (All Vehicles)	Weather Conditions	Most Harmful Event (All Vehicles)
4180921	04/21/2016	Thu	Not Reported	10:30 AM	Daylight	Angle	V1: Parked	Clear	V1:(Collision with parked motor vehicle)
4236882	07/01/2016	Fri	Property damage only (none injured)	1:17 PM	Daylight	Angle	V1: Travelling straight ahead / V2: Travelling straight ahead	Clear	V1:(Collision with motor vehicle in traffic) / V2:(Collision with motor vehicle in traffic)
4209999	06/23/2016	Thu	Property damage only (none injured)	5:00 PM	Daylight	Angle	V1: Backing / V2: Travelling straight ahead	Clear	V1:(Collision with motor vehicle in traffic) / V2:(Collision with motor vehicle in traffic)
4138108	01/20/2016	Wed	Property damage only (none injured)	3:00 PM	Daylight	Angle	V1: Backing / V2: Travelling straight ahead	Clear/Clear	V1:(Collision with motor vehicle in traffic) / V2:(Collision with motor vehicle in traffic)
4750756	09/13/2019	Fri	Property damage only (none injured)	8:19 AM	Daylight	Front to Front	V1: Travelling straight ahead / V2: Turning left	Clear	V1:(Collision with motor vehicle in traffic) / V2:(Collision with motor vehicle in traffic)
4416371	08/30/2017	Wed	Non-fatal injury	8:16 PM	Dark - lighted roadway	Rear-end	V1: Travelling straight ahead / V2: Slowing or stopped in traffic	Clear/Clear	V1:(Collision with motor vehicle in traffic) / V2:(Collision with motor vehicle in traffic)
4253658	09/23/2016	Fri	Property damage only (none injured)	1:56 PM	Daylight	Rear-end	V1: Backing / V2: Travelling straight ahead	Clear/Clear	V2:(Collision with motor vehicle in traffic)
4642180	12/22/2018	Sat	Property damage only (none injured)	11:05 AM	Daylight	Rear-end	V1: Travelling straight ahead / V2: Travelling straight ahead	Rain/Cloudy	V1:(Collision with motor vehicle in traffic) / V2:(Collision with motor vehicle in traffic)
4378461	06/15/2017	Thu	Property damage only (none injured)	4:49 PM	Daylight	Rear-end	V1: Slowing or stopped in traffic / V2: Slowing or stopped in traffic / V3: Changing lanes	Clear	V1:(Collision with motor vehicle in traffic) / V2:(Collision with motor vehicle in traffic) / V3:(Collision with motor vehicle in traffic)
4537855	05/09/2018	Wed	Property damage only (none injured)	3:51 PM	Daylight	Rear-end	V1: Travelling straight ahead / V2: Travelling straight ahead	Clear	V1:(Collision with motor vehicle in traffic) / V2:(Collision with motor vehicle in traffic)
4449080	11/02/2017	Thu	Property damage only (none injured)	6:38 PM	Dark - lighted roadway	Sideswipe, same direction	V1: Turning right / V2: Turning left	Clear	V1:(Collision with motor vehicle in traffic) / V2:(Collision with motor vehicle in traffic)
4796161	12/28/2019	Sat	Non-fatal injury	4:09 PM	Daylight	Single vehicle crash	V1: Turning left	Clear	V1:(Collision with other fixed object (wall, building, tunnel, etc.))
4050168	06/02/2015	Tue	Property damage only (none injured)	12:40 PM	Daylight	Single vehicle crash	V1: Slowing or stopped in traffic / V2: Travelling straight ahead	Rain	V1:(Collision with motor vehicle in traffic) / V2:(Collision with motor vehicle in traffic)
4140158	01/18/2016	Mon	Not Reported	2:07 PM	Daylight	Unknown	V1: Parked	Clear	V1:(Collision with parked motor vehicle)

MassDOT Crash Report for Route 140 at King Street and Chestnut Street

Crash Number	Crash Date	Day	Crash Severity	Crash Time	Light Conditions	Manner of Collision	Vehicle Actions Prior to Crash (All Vehicles)	Weather Conditions	Most Harmful Event (All Vehicles)
4008798	02/13/2015	Fri	Non-fatal injury	6:42 PM	Dark - lighted roadway	Single vehicle crash	V1: Travelling straight ahead	Cloudy	V1:(Collision with pedestrian)
4069990	07/29/2015	Wed	Property damage only (none injured)	11:07 AM	Daylight	Rear-end	V1: Slowing or stopped in traffic / V2: Travelling straight ahead	Clear	V1:(Collision with motor vehicle in traffic) / V2:(Collision with motor vehicle in traffic)
4090243	09/21/2015	Mon	Property damage only (none injured)	12:17 PM	Daylight	Angle	V1: Travelling straight ahead / V2: Entering traffic lane	Clear	V1:(Collision with motor vehicle in traffic) / V2:(Collision with motor vehicle in traffic)
4155614	02/25/2016	Thu	Property damage only (none injured)	3:00 PM	Daylight	Rear-end	V1: Slowing or stopped in traffic / V2: Travelling straight ahead	Not Reported	V1:(Collision with motor vehicle in traffic) / V2:(Collision with motor vehicle in traffic)
4166118	03/18/2016	Fri	Non-fatal injury	10:55 AM	Daylight	Rear-end	V1: Slowing or stopped in traffic / V2: Slowing or stopped in traffic	Not Reported	V1:(Collision with motor vehicle in traffic) / V2:(Collision with motor vehicle in traffic)
4174861	04/04/2016	Mon	Property damage only (none injured)	2:28 PM	Daylight	Angle	V1: Slowing or stopped in traffic / V2: Turning right	Snow	V1:(Collision with motor vehicle in traffic) / V2:(Collision with motor vehicle in traffic)
4193872	05/19/2016	Thu	Property damage only (none injured)	7:14 PM	Dusk	Sideswipe, same direction	V1: Changing lanes / V2: Travelling straight ahead	Rain	V1:(Collision with motor vehicle in traffic) / V2:(Collision with motor vehicle in traffic)
4212740	06/28/2016	Tue	Non-fatal injury	5:30 PM	Daylight	Rear-end	V1: Slowing or stopped in traffic / V2: Travelling straight ahead	Cloudy	V1:(Collision with motor vehicle in traffic) / V2:(Collision with motor vehicle in traffic)
4219153	07/15/2016	Fri	Property damage only (none injured)	5:24 PM	Daylight	Rear-end	V1: Travelling straight ahead / V2: Travelling straight ahead	Clear	V1:(Collision with motor vehicle in traffic) / V2:(Collision with motor vehicle in traffic)
4281646	11/08/2016	Tue	Property damage only (none injured)	1:25 PM	Daylight	Angle	V1: Travelling straight ahead / V2: Turning right	Clear/Clear	V1:(Collision with motor vehicle in traffic) / V2:(Collision with motor vehicle in traffic)
4293152	11/15/2016	Tue	Property damage only (none injured)	5:11 PM	Dark - lighted roadway	Sideswipe, same direction	V1: Turning left / V2: Changing lanes	Rain/Cloudy	V1:(Collision with motor vehicle in traffic) / V2:(Collision with motor vehicle in traffic)
4301699	12/20/2016	Tue	Property damage only (none injured)	3:02 PM	Daylight	Sideswipe, same direction	V1: Travelling straight ahead / V2: Travelling straight ahead	Clear/Clear	V1:(Collision with motor vehicle in traffic) / V2:(Collision with motor vehicle in traffic)
4303100	12/23/2016	Fri	Property damage only (none injured)	3:21 PM	Daylight	Rear-end	V1: Travelling straight ahead / V2: Slowing or stopped in traffic	Clear	V1:(Collision with motor vehicle in traffic) / V2:(Collision with other movable object)
4316023	01/19/2017	Thu	Non-fatal injury	3:22 PM	Daylight	Rear-end	V1: Slowing or stopped in traffic / V2: Slowing or stopped in traffic	Clear	V1:(Collision with motor vehicle in traffic) / V2:(Collision with motor vehicle in traffic)
4328637	02/16/2017	Thu	Property damage only (none injured)	12:23 PM	Daylight	Sideswipe, same direction	V1: Travelling straight ahead / V2: Travelling straight ahead	Clear	V1:(Collision with motor vehicle in traffic) / V2:(Collision with motor vehicle in traffic)
4328640	02/17/2017	Fri	Property damage only (none injured)	9:35 PM	Dark - lighted roadway	Rear-end	V1: Travelling straight ahead / V2: Slowing or stopped in traffic	Clear	V1:(Collision with motor vehicle in traffic) / V2:(Collision with motor vehicle in traffic)
4387123	07/06/2017	Thu	Non-fatal injury	6:02 PM	Daylight	Angle	V1: Turning left / V2: Travelling straight ahead	Clear	V1:(Collision with motor vehicle in traffic) / V2:(Collision with motor vehicle in traffic)
4398959	07/28/2017	Fri	Property damage only (none injured)	3:49 PM	Daylight	Rear-end	V1: Travelling straight ahead / V2: Travelling straight ahead	Clear/Clear	V1:(Collision with motor vehicle in traffic) / V2:(Collision with motor vehicle in traffic)
4458702	11/26/2017	Sun	Property damage only (none injured)	3:10 PM	Daylight	Angle	V1: Travelling straight ahead / V2: Travelling straight ahead	Clear	V1:(Collision with motor vehicle in traffic) / V2:(Collision with motor vehicle in traffic)
4517979	03/16/2018	Fri	Property damage only (none injured)	11:44 AM	Daylight	Rear-end	V1: Slowing or stopped in traffic / V2: Travelling straight ahead	Cloudy	V1:(Collision with motor vehicle in traffic) / V2:(Collision with motor vehicle in traffic)
4518572	03/23/2018	Fri	Property damage only (none injured)	7:03 PM	Dusk	Sideswipe, same direction	V1: Turning right / V2: Travelling straight ahead	Clear/Clear	V1:(Collision with motor vehicle in traffic) / V2:(Collision with motor vehicle in traffic)
4580434	08/10/2018	Fri	Property damage only (none injured)	8:17 PM	Dark - lighted roadway	Angle	V1: Turning left / V2: Travelling straight ahead	Clear/Clear	V1:(Collision with motor vehicle in traffic) / V2:(Collision with motor vehicle in traffic)
4602117	09/21/2018	Fri	Property damage only (none injured)	2:30 PM	Daylight	Rear-end	V1: Slowing or stopped in traffic / V2: Slowing or stopped in traffic	Clear	V1:(Collision with motor vehicle in traffic) / V2:(Collision with motor vehicle in traffic)
4696123	04/25/2019	Thu	Non-fatal injury	8:42 PM	Dark - lighted roadway	Front to Front	V1: Travelling straight ahead / V2: Travelling straight ahead / V3: Slowing or stopped in traffic	Clear/Clear	V1:(Collision with motor vehicle in traffic) / V2:(Collision with motor vehicle in traffic) / V3:(Collision with motor vehicle in traffic)
4706202	05/19/2019	Sun	Property damage only (none injured)	12:34 PM	Daylight	Angle	V1: Entering traffic lane / V2: Travelling straight ahead	Clear	V1:(Collision with motor vehicle in traffic) / V2:(Collision with motor vehicle in traffic)
4743120	08/28/2019	Wed	Property damage only (none injured)	1:01 PM	Daylight	Angle	V1: Slowing or stopped in traffic / V2: Turning left	Rain/Cloudy	V1:(Collision with motor vehicle in traffic) / V2:(Collision with motor vehicle in traffic)
4770790	11/03/2019	Sun	Non-fatal injury	2:56 PM	Daylight	Rear-end	V1: Slowing or stopped in traffic / V2: Slowing or stopped in traffic / V3: Slowing or stopped in traffic	Clear	V1:(Collision with motor vehicle in traffic) / V2:(Collision with motor vehicle in traffic) / V3:(Collision with motor vehicle in traffic)
4774002	11/10/2019	Sun	Property damage only (none injured)	8:01 AM	Daylight	Single vehicle crash	V1: Travelling straight ahead	Cloudy/Cloudy	V1:(Collision with motor vehicle in traffic)
4786266	12/05/2019	Thu	Non-fatal injury	4:17 PM	Daylight	Rear-end	V1: Slowing or stopped in traffic / V2: Travelling straight ahead	Clear	V1:(Collision with motor vehicle in traffic) / V2:(Collision with motor vehicle in traffic)

MassDOT Crash Data for Route 140 at Project Driveway

Crash Number	Crash Date	Day	Crash Severity	Crash Time	Light Conditions	Manner of Collision	Vehicle Actions Prior to Crash (All Vehicles)	Weather Conditions	Most Harmful Event (All Vehicles)
4123115	12/05/2015	Sat	Non-fatal injury	10:31 PM	Dark - lighted roadway	Single vehicle crash	V1: Travelling straight ahead	Clear	V1:(Collision with pedestrian)
4140664	01/25/2016	Mon	Property damage only (none injured)	2:02 PM	Daylight	Sideswipe, same direction	V1: Parked / V2: Turning left	Clear	V1:(Collision with motor vehicle in traffic) / V2:(Collision with motor vehicle in traffic)
4188739	04/29/2016	Fri	Property damage only (none injured)	2:17 PM	Daylight	Angle	V1: Turning left / V2: Overtaking/passing	Clear	V1:(Collision with motor vehicle in traffic) / V2:(Collision with motor vehicle in traffic)
4209918	06/20/2016	Mon	Property damage only (none injured)	4:43 PM	Daylight	Angle	V1: Travelling straight ahead / V2: Entering traffic lane	Clear	V1:(Collision with motor vehicle in traffic) / V2:(Collision with motor vehicle in traffic)
4297594	12/07/2016	Wed	Non-fatal injury	9:01 AM	Daylight	Rear-end	V1: Slowing or stopped in traffic / V2: Travelling straight ahead / V3: Travelling straight ahead	Cloudy	V1:(Collision with motor vehicle in traffic) / V2:(Collision with motor vehicle in traffic) / V3:(Collision with motor vehicle in traffic)
4412189	08/23/2017	Wed	Property damage only (none injured)	8:05 AM	Daylight	Sideswipe, same direction	V1: Travelling straight ahead / V2: Entering traffic lane	Cloudy/Cloudy	V1:(Collision with motor vehicle in traffic) / V2:(Collision with motor vehicle in traffic)
4458815	11/21/2017	Tue	Property damage only (none injured)	2:47 PM	Daylight	Angle	V1: Turning left / V2: Travelling straight ahead	Clear/Clear	V1:(Collision with motor vehicle in traffic) / V2:(Collision with motor vehicle in traffic)
4786788	12/06/2019	Fri	Property damage only (none injured)	2:04 PM	Daylight	Angle	V1: Travelling straight ahead / V2: Travelling straight ahead	Clear	V1:(Collision with motor vehicle in traffic) / V2:(Collision with motor vehicle in traffic)

BACKGROUND DEVELOPMENT NETWORKS



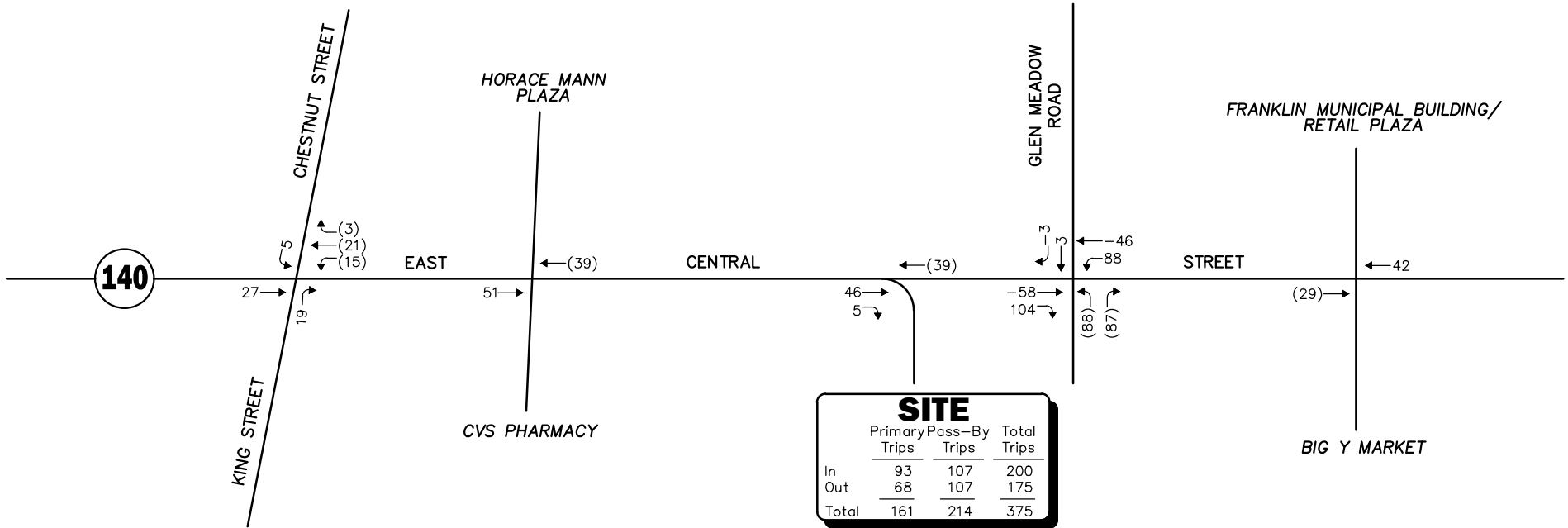

Note: Imbalances exist due to numerous curb cuts and side streets that are not shown.

Not To Scale

Figure 11

Project-Generated
Weekday Morning
Peak Hour Traffic Volumes



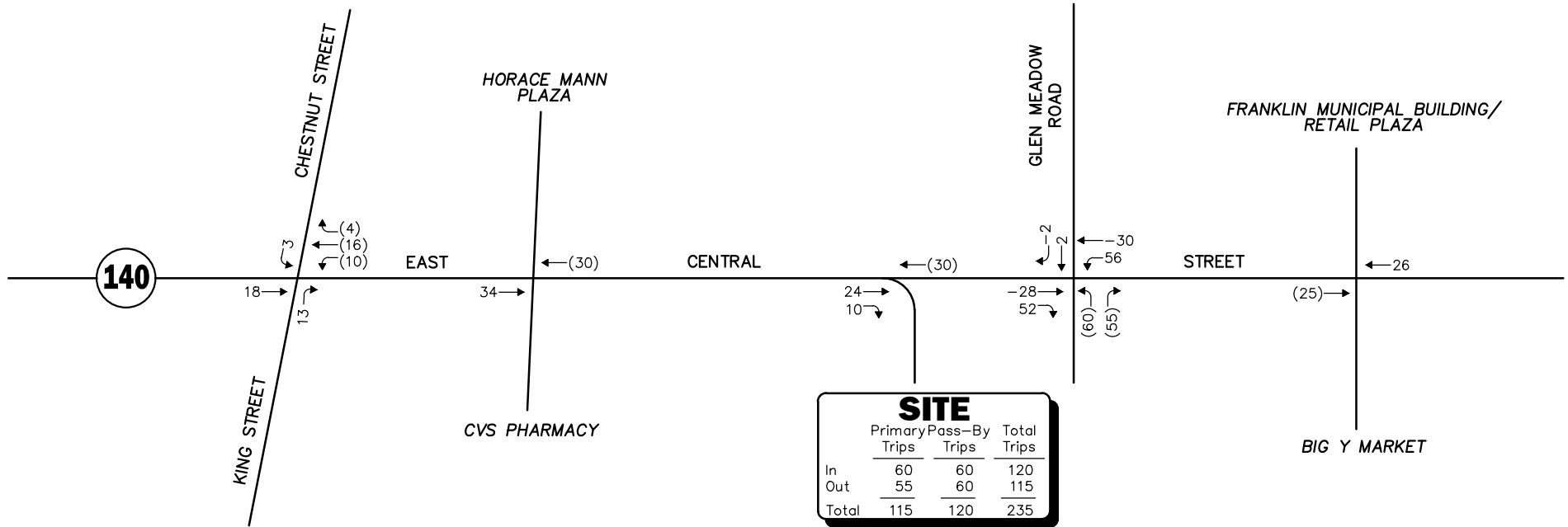

Note: Imbalances exist due to numerous curb cuts and side streets that are not shown.
 Not To Scale

Figure 12

Project-Generated
 Weekday Evening
 Peak Hour Traffic Volumes



GENERAL BACKGROUND TRAFFIC GROWTH



General Background Traffic Growth - Daily Traffic Volumes

CITY/TOWN	ROUTE/STREET	LOCATION	2009	2010	2011	2012	2013	2014	2015	2016	2017	2018	2019	Annual Growth Rate
Franklin	Route 140	West of Beaver Street	20,620	20,846	20,217	20,697	20,719	20,109	20,330		21,200	21,264		0.15%
Franklin	Interstate 495	South of Route 140	72,318	72,712		80,371	77,245	83,722	88,584	87,263	87,001	83,551	89,222	1.96%
Franklin	Pleasant Street	at Norfolk Town Line	11,900	11,828	11,816	10,232	10,302	10,621	9,519	10,109	10,281	11,724	11,677	-0.41%
														0.57%

TRIP-GENERATION CALCULATIONS



Graph Look Up

ITETripGen Web-based App

[Graph Look Up](#)

[How to Use ITETripGen](#)

[TGM Desk References](#)

[TGM Appendices](#)

[Support Documents](#)

[Add Users](#)

[Comments](#)

[Actions \(16 items\)](#)

[Try OTISS Pro](#)

Data Plot and Equation

Query Filter

DATA SOURCE:

SEARCH BY LAND USE CODE:

LAND USE GROUP:

LAND USE:

LAND USE SUBCATEGORY:

SETTING/LOCATION:

INDEPENDENT VARIABLE (IV):

TIME PERIOD:

TRIP TYPE:

ENTER IV VALUE TO CALCULATE TRIPS:

DATA STATISTICS

Land Use:
Multifamily Housing (Low-Rise) - Not Close to Rail Transit (220). Click for Description and Data Plots

Independent Variable:
Dwelling Units

Time Period:
Weekday

Setting/Location:
General Urban/Suburban

Trip Type:
Vehicle

Number of Studies:
22

Avg. Num. of Dwelling Units:
229

Average Rate:
6.74

Range of Rates:
2.46 - 12.50

Standard Deviation:
1.79

Fitted Curve Equation:
 $T = 6.41(X) + 75.31$

R²:
0.86

Directional Distribution:
50% entering, 50% exiting

Calculated Trip Ends:
Average Rate: 236 (Total), 118 (Entry), 118 (Exit)
Fitted Curve: 300 (Total), 150 (Entry), 150 (Exit)

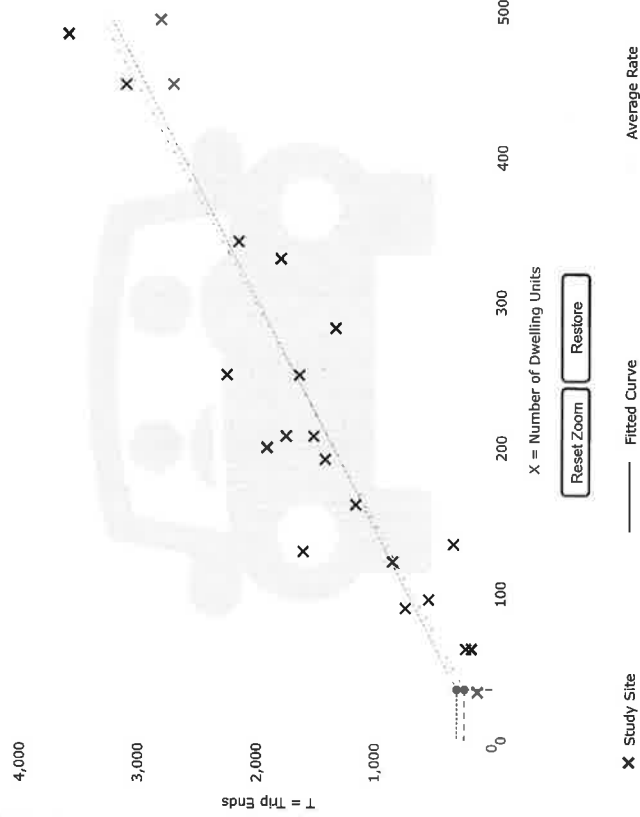

Use the mouse wheel to Zoom Out or Zoom In.
Hover the mouse pointer on data points to view X and T values.

Graph Look Up

ITETripGen Web-based App

Graph Look Up

How to Use ITETripGen

TSM Desk Reference

TSM Applications

Support Documents

Add Users

Comments

Autosave to PDF

Try OTISS Pro

Query Filter

DATA SOURCE: Trip Generation Manual, 11th Ed

SEARCH BY LAND USE CODE: 220

LAND USE GROUP: (200-299) Residential

LAND USE: 220 - Multifamily Housing (Low-Rise)

LAND USE SUBCATEGORY: Not Close to Rail Transit

SETTING/LOCATION: General Urban/Suburban

INDEPENDENT VARIABLE (IV): Dwelling Units

TIME PERIOD: Weekday, Peak Hour of Adjacent Street Traffic

TRIP TYPE: Vehicle

ENTER IV VALUE TO CALCULATE TRIPS: 35

Data Plot and Equation

Land Use: Multifamily Housing (Low-Rise) - Not Close to Rail Transit (220) Click for Description and Data Plots

Independent Variable: Dwelling Units

Time Period: Weekday
Peak Hour of Adjacent Street Traffic
One Hour Between 7 and 9 a.m.

Setting/Location: General Urban/Suburban

Trip Type: Vehicle

Number of Studies: 49

Avg. Num. of Dwelling Units: 249

Average Rate: 0.40

Range of Rates: 0.13 - 0.73

Standard Deviation: 0.12

Fitted Curve Equation: $T = 0.31(X) + 22.85$

R²: 0.79

Directional Distribution: 24% entering, 76% exiting

Calculated Trip Ends: -
Average Rate: 14 (Total), 3 (Entry), 11 (Exit)
Fitted Curve: 34 (Total), 8 (Entry), 26 (Exit)

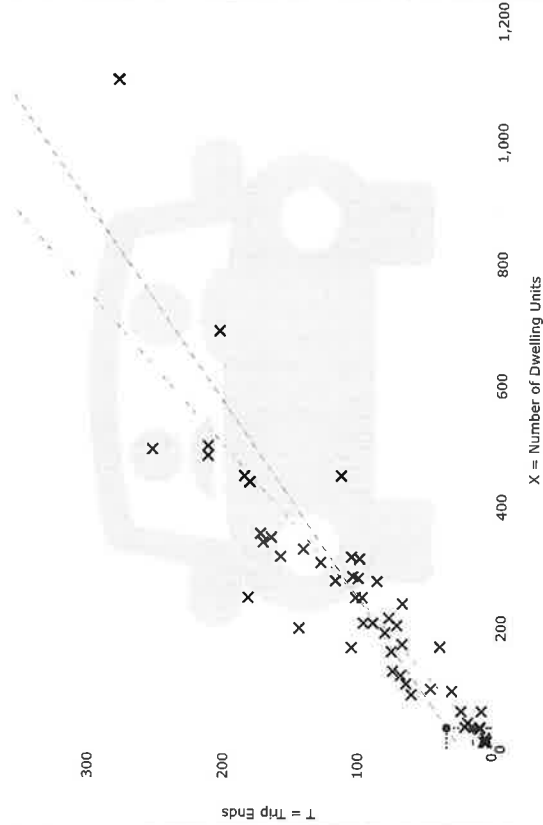

Study Site Fitted Curve Average Rate

Use the mouse wheel to Zoom Out or Zoom In.
Hover the mouse pointer on data points to view X and T values.



ITETripGen Web-based App

Graph Look Up

How to Use ITETripGen

TGM Peak Refinement

TGM Agencies

Support Documents

ADD LINK

Comments

Build-one-to-estimate

Try-OTIES Pro

Data Plot and Equation

Query Filter

DATA SOURCE: Trip Generation Manual, 11th Ed

SEARCH BY LAND USE CODE: 220

LAND USE GROUP: (200-299) Residential

LAND USE: 220 - Multifamily Housing (Low-Rise)

LAND USE SUBCATEGORY: Not Close to Rail Transit

SETTING/LOCATION: General Urban/Suburban

INDEPENDENT VARIABLE (X): Dwelling Units

TIME PERIOD: Weekday, Peak Hour of Adjacent Street Traffic

TRIP TYPE: Vehicle

ENTER IV VALUE TO CALCULATE TRIPS: 35

DATA STATISTICS

Land Use: Multifamily Housing (Low-Rise) - Not Close to Rail Transit (220) [Click for Description and Data Plots](#)

Independent Variable: Dwelling Units

Time Period: Weekday
Peak Hour of Adjacent Street Traffic
One Hour Between 4 and 6 p.m.

Setting/Location: General Urban/Suburban

Trip Type: Vehicle

Number of Studies: 59

Avg. Num. of Dwelling Units: 241

Average Rate: 0.51

Range of Rates: 0.08 - 1.04

Standard Deviation: 0.15

Fitted Curve Equation: $T = 0.43(X) + 20.55$

R²: 0.84

Directional Distribution: 63% entering, 37% exiting

Calculated Trip Ends:

Average Rate: 18 (Total), 11 (Entry), 7 (Exit)

Fitted Curve: 36 (Total), 22 (Entry), 14 (Exit)

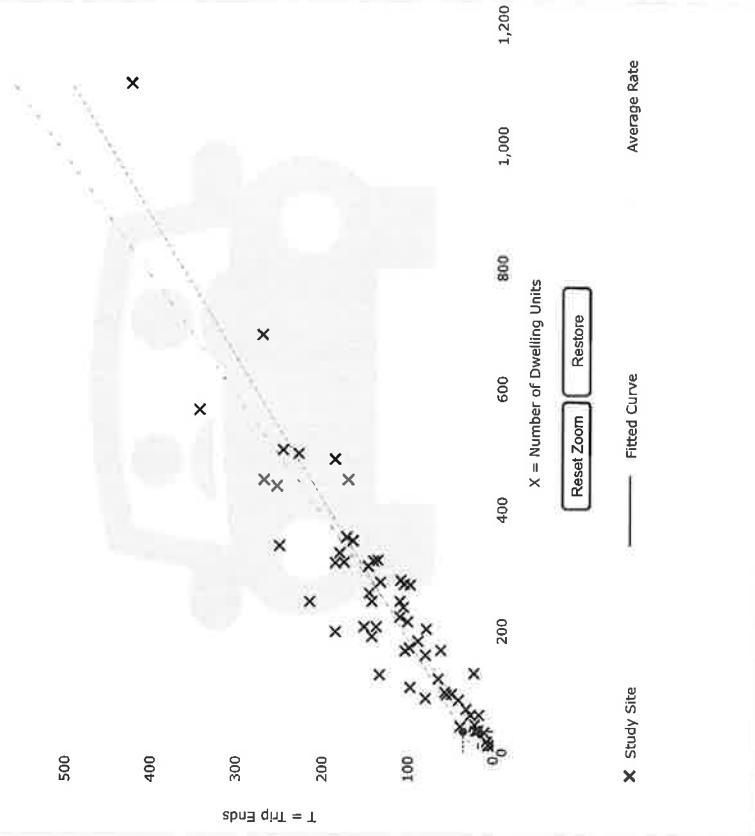

Use the mouse wheel to Zoom Out or Zoom In.
Hover the mouse pointer on data points to view X and T values.

Graph Look Up

ITETripGen Web-based App

Graph Look Up

How to Use ITETripGen

TGM Desk Reference

TGM Appendices

Support Documents

Add Users

Comments

Authors to do more

Try OTISS Pro

Query Filter

DATA SOURCE: Trip Generation Manual, 11th Ed

SEARCH BY LAND USE CODE: 712

LAND USE GROUP: (700-799) Office

LAND USE: 712 - Small Office Building

LAND USE SUBCATEGORY: All Sites

SETTING/LOCATION: General Urban/Suburban

INDEPENDENT VARIABLE (IV): 1000 Sq. Ft. GFA

TIME PERIOD: Weekday

TRIP TYPE: Vehicle

ENTER IV VALUE TO CALCULATE TRIPS: 0.9

Data Plot and Equation

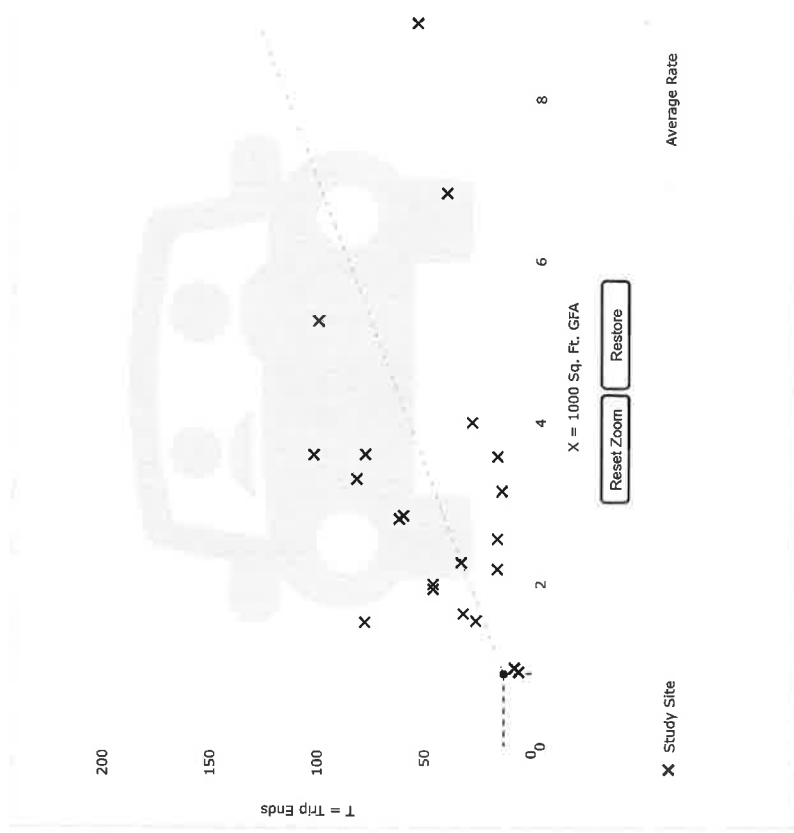

Use the mouse wheel to Zoom Out or Zoom In. Hover the mouse pointer on data points to view X and Y values.



ITETripGen Web-based App

[Graph Look Up](#)

[How to Use ITETripGen](#)

[TGM Desk Reference](#)

[TGM Appendices](#)

[Support Documents](#)

[Add Users](#)

[Comments](#)

Query

DATA SOURCE:

SEARCH BY LAND USE CODE:

LAND USE GROUP:

LAND USE:

LAND USE SUBCATEGORY:

SETTING/LOCATION:

INDEPENDENT VARIABLE (IV):

TIME PERIOD:

TRIP TYPE:

ENTER IV VALUE TO CALCULATE TRIPS:

Data Plot and Equation



Use the mouse wheel to Zoom Out or Zoom In.
Hover the mouse pointer on data points to view X and T values.

Graph Look Up

ITETripGen Web-based App

Graph Look Up

How to Use ITETripGen

TGM Desk Reference

TGM Appendices

Support Documents

Add Users

Comments

Query Filter

DATA SOURCE: Trip Generation Manual, 11th Ed

SEARCH BY LAND USE CODE: 712

LAND USE GROUP: (700-799) Office

LAND USE: 712 - Small Office Building

LAND USE SUBCATEGORY: All Sites

SETTING/LOCATION: General Urban/Suburban

INDEPENDENT VARIABLE (IV): 1000 Sq. Ft. GFA

TIME PERIOD: Weekday, Peak Hour of Adjacent Street Traffic

TRIP TYPE: Vehicle

ENTER IV VALUE TO CALCULATE TRIPS: 0.9

Data Plot and Equation

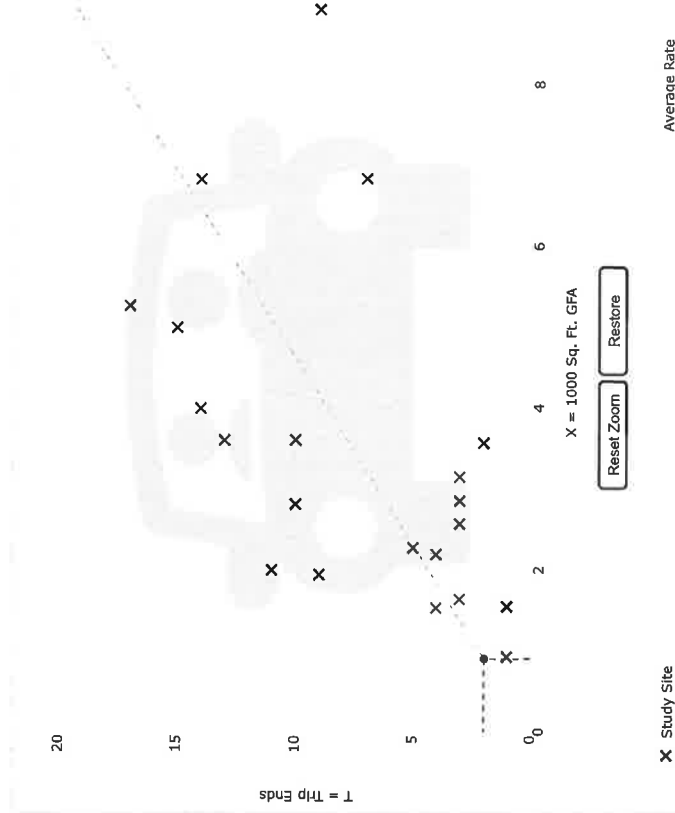

Use the mouse wheel to Zoom Out or Zoom In.
Hover the mouse pointer on data points to view X and T values.

CAPACITY ANALYSIS WORKSHEETS

2022 Existing

2029 No-Build

2029 Build

2029 Build with Mitigation



2022 Existing



2022 Existing Weekday Morning Peak Hour
1: King St/Chestnut St & Route 140

01/18/2022



Lane Group	EBL	EBT	EBR	WBL	WBT	WBR	NEL	NET	NER	SWL	SWT	SWR
Lane Configurations												
Traffic Volume (vph)	78	322	33	212	268	55	26	342	301	18	253	99
Future Volume (vph)	78	322	33	212	268	55	26	342	301	18	253	99
Ideal Flow (vphpl)	1900	1900	1900	1900	1900	1900	1900	1900	1900	1900	1900	1900
Lane Width (ft)	12	11	11	11	11	11	11	11	11	16	16	16
Storage Length (ft)	100		50	165		50	0		80	0		0
Storage Lanes	1		0	1		0	0		1	0		0
Taper Length (ft)	25			25			25			25		
Right Turn on Red			Yes			Yes			Yes			Yes
Link Speed (mph)		30			30			30				30
Link Distance (ft)		639			1214			457				724
Travel Time (s)		14.5			27.6			10.4				16.5
Peak Hour Factor	0.92	0.92	0.92	0.99	0.99	0.99	0.89	0.89	0.89	0.90	0.90	0.90
Heavy Vehicles (%)	6%	2%	0%	1%	2%	0%	0%	2%	1%	11%	2%	3%
Shared Lane Traffic (%)												
Lane Group Flow (vph)	85	386	0	214	327	0	0	413	338	0	411	0
Turn Type	pm+pt	NA		pm+pt	NA		Perm	NA	pm+ov	Perm	NA	
Protected Phases	5	2		1	6			8	1			4
Permitted Phases	2			6			8		8	4		
Detector Phase	5	2		1	6		8	8	1	4		4
Switch Phase												
Minimum Initial (s)	6.0	6.0		6.0	6.0		6.0	6.0	6.0	6.0		6.0
Minimum Split (s)	11.0	21.0		11.0	21.0		21.0	21.0	11.0	21.0		21.0
Total Split (s)	20.0	40.0		20.0	40.0		35.0	35.0	20.0	35.0		35.0
Total Split (%)	17.1%	34.2%		17.1%	34.2%		29.9%	29.9%	17.1%	29.9%		29.9%
Yellow Time (s)	3.0	3.0		3.0	3.0		3.0	3.0	3.0	3.0		3.0
All-Red Time (s)	2.0	2.0		2.0	2.0		2.0	2.0	2.0	2.0		2.0
Lost Time Adjust (s)	-1.0	-1.0		-1.0	-1.0			-1.0	-1.0			-1.0
Total Lost Time (s)	4.0	4.0		4.0	4.0			4.0	4.0			4.0
Lead/Lag	Lead	Lag		Lead	Lag				Lead			
Lead-Lag Optimize?	Yes	Yes		Yes	Yes				Yes			
Recall Mode	None	None		None	None		None	None	None	None		None
v/c Ratio	0.20	0.76		0.56	0.52			0.62	0.35			0.54
Control Delay	14.1	38.1		19.5	26.3			30.1	7.0			26.4
Queue Delay	0.0	0.0		0.0	0.0			0.0	0.0			0.0
Total Delay	14.1	38.1		19.5	26.3			30.1	7.0			26.4
Queue Length 50th (ft)	21	165		56	124			156	29			143
Queue Length 95th (ft)	63	363		143	284			#470	141			#395
Internal Link Dist (ft)		559			1134			377				644
Turn Bay Length (ft)	100			165					80			
Base Capacity (vph)	562	794		452	799			662	1044			761
Starvation Cap Reductn	0	0		0	0			0	0			0
Spillback Cap Reductn	0	0		0	0			0	0			0
Storage Cap Reductn	0	0		0	0			0	0			0
Reduced v/c Ratio	0.15	0.49		0.47	0.41			0.62	0.32			0.54

Intersection Summary

Area Type: Other
Cycle Length: 117

2022 Existing Weekday Morning Peak Hour
 1: King St/Chestnut St & Route 140

01/18/2022

Lane Group	Ø9
Lane Configurations	
Traffic Volume (vph)	
Future Volume (vph)	
Ideal Flow (vphpl)	
Lane Width (ft)	
Storage Length (ft)	
Storage Lanes	
Taper Length (ft)	
Right Turn on Red	
Link Speed (mph)	
Link Distance (ft)	
Travel Time (s)	
Peak Hour Factor	
Heavy Vehicles (%)	
Shared Lane Traffic (%)	
Lane Group Flow (vph)	
Turn Type	
Protected Phases	9
Permitted Phases	
Detector Phase	
Switch Phase	
Minimum Initial (s)	4.0
Minimum Split (s)	21.0
Total Split (s)	22.0
Total Split (%)	19%
Yellow Time (s)	3.0
All-Red Time (s)	2.0
Lost Time Adjust (s)	
Total Lost Time (s)	
Lead/Lag	
Lead-Lag Optimize?	
Recall Mode	None
v/c Ratio	
Control Delay	
Queue Delay	
Total Delay	
Queue Length 50th (ft)	
Queue Length 95th (ft)	
Internal Link Dist (ft)	
Turn Bay Length (ft)	
Base Capacity (vph)	
Starvation Cap Reductn	
Spillback Cap Reductn	
Storage Cap Reductn	
Reduced v/c Ratio	
Intersection Summary	

2022 Existing Weekday Morning Peak Hour
 1: King St/Chestnut St & Route 140

01/18/2022

Actuated Cycle Length: 83.7







Natural Cycle: 90

Control Type: Actuated-Uncoordinated

95th percentile volume exceeds capacity, queue may be longer.

Queue shown is maximum after two cycles.

Splits and Phases: 1: King St/Chestnut St & Route 140

 Ø4	 Ø1	 Ø2	 Ø9
35 s	20 s	40 s	22 s
 Ø8	 Ø5	 Ø6	
35 s	20 s	40 s	

2022 Existing Weekday Morning Peak Hour
1: King St/Chestnut St & Route 140

01/18/2022

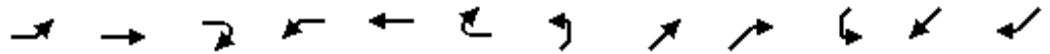

Movement	EBL	EBT	EBR	WBL	WBT	WBR	NEL	NET	NER	SWL	SWT	SWR
Lane Configurations												
Traffic Volume (vph)	78	322	33	212	268	55	26	342	301	18	253	99
Future Volume (vph)	78	322	33	212	268	55	26	342	301	18	253	99
Ideal Flow (vphpl)	1900	1900	1900	1900	1900	1900	1900	1900	1900	1900	1900	1900
Lane Width	12	11	11	11	11	11	11	11	11	16	16	16
Total Lost time (s)	4.0	4.0		4.0	4.0			4.0	4.0		4.0	
Lane Util. Factor	1.00	1.00		1.00	1.00			1.00	1.00		1.00	
Frt	1.00	0.99		1.00	0.97			1.00	0.85		0.96	
Flt Protected	0.95	1.00		0.95	1.00			1.00	1.00		1.00	
Satd. Flow (prot)	1703	1779		1728	1760			1797	1546		2016	
Flt Permitted	0.46	1.00		0.22	1.00			0.96	1.00		0.97	
Satd. Flow (perm)	823	1779		391	1760			1728	1546		1962	
Peak-hour factor, PHF	0.92	0.92	0.92	0.99	0.99	0.99	0.89	0.89	0.89	0.90	0.90	0.90
Adj. Flow (vph)	85	350	36	214	271	56	29	384	338	20	281	110
RTOR Reduction (vph)	0	4	0	0	6	0	0	0	94	0	10	0
Lane Group Flow (vph)	85	382	0	214	321	0	0	413	244	0	401	0
Heavy Vehicles (%)	6%	2%	0%	1%	2%	0%	0%	2%	1%	11%	2%	3%
Turn Type	pm+pt	NA		pm+pt	NA		Perm	NA	pm+ov	Perm	NA	
Protected Phases	5	2		1	6			8	1		4	
Permitted Phases	2			6			8		8	4		
Actuated Green, G (s)	30.8	24.1		39.8	28.6			31.1	42.3		31.1	
Effective Green, g (s)	32.8	25.1		41.3	29.6			32.1	44.3		32.1	
Actuated g/C Ratio	0.37	0.28		0.47	0.33			0.36	0.50		0.36	
Clearance Time (s)	5.0	5.0		5.0	5.0			5.0	5.0		5.0	
Vehicle Extension (s)	3.0	3.0		3.0	3.0			3.0	3.0		3.0	
Lane Grp Cap (vph)	380	503		365	587			625	841		710	
v/s Ratio Prot	0.02	c0.21		c0.08	0.18				0.04			
v/s Ratio Perm	0.06			0.19				c0.24	0.12		0.20	
v/c Ratio	0.22	0.76		0.59	0.55			0.66	0.29		0.57	
Uniform Delay, d1	18.7	29.1		16.6	24.1			23.7	13.0		22.7	
Progression Factor	1.00	1.00		1.00	1.00			1.00	1.00		1.00	
Incremental Delay, d2	0.3	6.7		2.4	1.0			2.6	0.2		1.0	
Delay (s)	19.0	35.7		19.0	25.1			26.4	13.2		23.7	
Level of Service	B	D		B	C			C	B		C	
Approach Delay (s)		32.7			22.7			20.4			23.7	
Approach LOS		C			C			C			C	

Intersection Summary

HCM 2000 Control Delay	24.3	HCM 2000 Level of Service	C
HCM 2000 Volume to Capacity ratio	0.66		
Actuated Cycle Length (s)	88.7	Sum of lost time (s)	17.0
Intersection Capacity Utilization	75.3%	ICU Level of Service	D
Analysis Period (min)	15		

c Critical Lane Group

2022 Existing Weekday Morning Peak Hour
2: CVS Dwy/Horace Mann Plaza Dwy & Route 140

01/18/2022



Lane Group	EBL	EBT	EBR	WBL	WBT	WBR	NBL	NBT	NBR	SBL	SBT	SBR
Lane Configurations												
Traffic Volume (vph)	91	529	19	7	448	55	19	4	12	71	5	61
Future Volume (vph)	91	529	19	7	448	55	19	4	12	71	5	61
Ideal Flow (vphpl)	1900	1900	1900	1900	1900	1900	1900	1900	1900	1900	1900	1900
Lane Width (ft)	10	11	11	11	11	11	11	11	11	13	13	12
Storage Length (ft)	160		50	100		150	0		26	50		0
Storage Lanes	1		1	1		1	0		1	0		1
Taper Length (ft)	25			25			25			25		
Right Turn on Red			Yes			Yes			Yes			Yes
Link Speed (mph)		30			30			30				30
Link Distance (ft)		1214			741			320				157
Travel Time (s)		27.6			16.8			7.3				3.6
Peak Hour Factor	0.87	0.87	0.87	0.85	0.85	0.85	0.82	0.82	0.82	0.85	0.85	0.85
Heavy Vehicles (%)	0%	2%	0%	0%	0%	0%	0%	0%	0%	0%	0%	0%
Shared Lane Traffic (%)												
Lane Group Flow (vph)	105	608	22	8	527	65	0	28	15	0	90	72
Turn Type	pm+pt	NA	custom	pm+pt	NA	custom	Perm	NA	Perm	Perm	NA	pm+ov
Protected Phases	5	2	2	1	6	6		8			4	5
Permitted Phases	2		2	6		6	8		8	4		4
Detector Phase	5	2	2	1	6	6	8	8	8	4	4	5
Switch Phase												
Minimum Initial (s)	5.0	10.0	10.0	5.0	10.0	10.0	5.0	5.0	5.0	5.0	5.0	5.0
Minimum Split (s)	10.0	15.0	15.0	10.0	15.0	15.0	9.0	9.0	9.0	9.0	9.0	10.0
Total Split (s)	20.0	44.0	44.0	20.0	44.0	44.0	24.0	24.0	24.0	24.0	24.0	20.0
Total Split (%)	18.2%	40.0%	40.0%	18.2%	40.0%	40.0%	21.8%	21.8%	21.8%	21.8%	21.8%	18.2%
Yellow Time (s)	4.0	4.0	4.0	4.0	4.0	4.0	3.0	3.0	3.0	3.0	3.0	4.0
All-Red Time (s)	1.0	1.0	1.0	1.0	1.0	1.0	1.0	1.0	1.0	1.0	1.0	1.0
Lost Time Adjust (s)	-1.0	-1.0	-1.0	-1.0	-1.0	-1.0		0.0	0.0		0.0	0.0
Total Lost Time (s)	4.0	4.0	4.0	4.0	4.0	4.0		4.0	4.0		4.0	5.0
Lead/Lag	Lead	Lag	Lag	Lead	Lag	Lag						Lead
Lead-Lag Optimize?												
Recall Mode	None	None	None	None	None	None	None	None	None	None	None	None
v/c Ratio	0.19	0.49	0.02	0.01	0.54	0.07		0.11	0.04		0.33	0.12
Control Delay	6.8	11.4	0.1	7.1	17.8	1.2		28.5	0.2		30.6	4.5
Queue Delay	0.0	0.0	0.0	0.0	0.0	0.0		0.0	0.0		0.0	0.0
Total Delay	6.8	11.4	0.1	7.1	17.8	1.2		28.5	0.2		30.6	4.5
Queue Length 50th (ft)	8	67	0	1	118	0		7	0		24	0
Queue Length 95th (ft)	54	425	0	8	369	5		38	0		96	19
Internal Link Dist (ft)		1134			661			240			77	
Turn Bay Length (ft)	160		50	100		150			26			
Base Capacity (vph)	841	1398	1236	918	1407	1221		638	815		682	952
Starvation Cap Reductn	0	0	0	0	0	0		0	0		0	0
Spillback Cap Reductn	0	0	0	0	0	0		0	0		0	0
Storage Cap Reductn	0	0	0	0	0	0		0	0		0	0
Reduced v/c Ratio	0.12	0.43	0.02	0.01	0.37	0.05		0.04	0.02		0.13	0.08

Intersection Summary

Area Type: Other
Cycle Length: 110

2022 Existing Weekday Morning Peak Hour
 2: CVS Dwy/Horace Mann Plaza Dwy & Route 140

01/18/2022

Lane Group	Ø9
Lane Configurations	
Traffic Volume (vph)	
Future Volume (vph)	
Ideal Flow (vphpl)	
Lane Width (ft)	
Storage Length (ft)	
Storage Lanes	
Taper Length (ft)	
Right Turn on Red	
Link Speed (mph)	
Link Distance (ft)	
Travel Time (s)	
Peak Hour Factor	
Heavy Vehicles (%)	
Shared Lane Traffic (%)	
Lane Group Flow (vph)	
Turn Type	
Protected Phases	9
Permitted Phases	
Detector Phase	
Switch Phase	
Minimum Initial (s)	4.0
Minimum Split (s)	21.0
Total Split (s)	22.0
Total Split (%)	20%
Yellow Time (s)	3.0
All-Red Time (s)	2.0
Lost Time Adjust (s)	
Total Lost Time (s)	
Lead/Lag	
Lead-Lag Optimize?	
Recall Mode	None
v/c Ratio	
Control Delay	
Queue Delay	
Total Delay	
Queue Length 50th (ft)	
Queue Length 95th (ft)	
Internal Link Dist (ft)	
Turn Bay Length (ft)	
Base Capacity (vph)	
Starvation Cap Reductn	
Spillback Cap Reductn	
Storage Cap Reductn	
Reduced v/c Ratio	
Intersection Summary	

2022 Existing Weekday Morning Peak Hour
 2: CVS Dwy/Horace Mann Plaza Dwy & Route 140



01/18/2022

Actuated Cycle Length: 53.4

Natural Cycle: 75

Control Type: Actuated-Uncoordinated

Splits and Phases: 2: CVS Dwy/Horace Mann Plaza Dwy & Route 140

 Ø1	 Ø2	 Ø4	 Ø9
20 s	44 s	24 s	22 s
 Ø5	 Ø6	 Ø8	
20 s	44 s	24 s	

2022 Existing Weekday Morning Peak Hour
2: CVS Dwy/Horace Mann Plaza Dwy & Route 140

01/18/2022



Movement	EBL	EBT	EBR	WBL	WBT	WBR	NBL	NBT	NBR	SBL	SBT	SBR
Lane Configurations												
Traffic Volume (vph)	91	529	19	7	448	55	19	4	12	71	5	61
Future Volume (vph)	91	529	19	7	448	55	19	4	12	71	5	61
Ideal Flow (vphpl)	1900	1900	1900	1900	1900	1900	1900	1900	1900	1900	1900	1900
Lane Width	10	11	11	11	11	11	11	11	11	13	13	12
Total Lost time (s)	4.0	4.0	4.0	4.0	4.0	4.0		4.0	4.0		4.0	5.0
Lane Util. Factor	1.00	1.00	1.00	1.00	1.00	1.00		1.00	1.00		1.00	1.00
Frt	1.00	1.00	0.85	1.00	1.00	0.85		1.00	0.85		1.00	0.85
Flt Protected	0.95	1.00	1.00	0.95	1.00	1.00		0.96	1.00		0.96	1.00
Satd. Flow (prot)	1685	1801	1561	1745	1837	1561		1764	1561		1876	1615
Flt Permitted	0.27	1.00	1.00	0.36	1.00	1.00		0.72	1.00		0.72	1.00
Satd. Flow (perm)	487	1801	1561	668	1837	1561		1323	1561		1413	1615
Peak-hour factor, PHF	0.87	0.87	0.87	0.85	0.85	0.85	0.82	0.82	0.82	0.85	0.85	0.85
Adj. Flow (vph)	105	608	22	8	527	65	23	5	15	84	6	72
RTOR Reduction (vph)	0	0	10	0	0	35	0	0	13	0	0	57
Lane Group Flow (vph)	105	608	12	8	527	30	0	28	2	0	90	15
Heavy Vehicles (%)	0%	2%	0%	0%	0%	0%	0%	0%	0%	0%	0%	0%
Turn Type	pm+pt	NA	custom	pm+pt	NA	custom	Perm	NA	Perm	Perm	NA	pm+ov
Protected Phases	5	2	2	1	6	6		8			4	5
Permitted Phases	2		2	6		6	8		8	4		4
Actuated Green, G (s)	38.6	33.0	33.0	28.3	27.7	27.7		7.1	7.1		7.1	13.0
Effective Green, g (s)	39.6	34.0	34.0	30.3	28.7	28.7		7.1	7.1		7.1	13.0
Actuated g/C Ratio	0.64	0.55	0.55	0.49	0.47	0.47		0.12	0.12		0.12	0.21
Clearance Time (s)	5.0	5.0	5.0	5.0	5.0	5.0		4.0	4.0		4.0	5.0
Vehicle Extension (s)	2.0	2.0	2.0	2.0	2.0	2.0		2.0	2.0		2.0	2.0
Lane Grp Cap (vph)	448	997	864	357	858	729		152	180		163	341
v/s Ratio Prot	c0.03	c0.34	0.01	0.00	0.29	0.02						0.00
v/s Ratio Perm	0.12			0.01				0.02	0.00		c0.06	0.01
v/c Ratio	0.23	0.61	0.01	0.02	0.61	0.04		0.18	0.01		0.55	0.04
Uniform Delay, d1	5.8	9.2	6.2	8.1	12.2	8.9		24.5	24.0		25.6	19.3
Progression Factor	1.00	1.00	1.00	1.00	1.00	1.00		1.00	1.00		1.00	1.00
Incremental Delay, d2	0.1	0.7	0.0	0.0	0.9	0.0		0.2	0.0		2.3	0.0
Delay (s)	5.9	10.0	6.2	8.1	13.1	8.9		24.7	24.0		27.9	19.3
Level of Service	A	A	A	A	B	A		C	C		C	B
Approach Delay (s)		9.3			12.6			24.5			24.1	
Approach LOS		A			B			C			C	

Intersection Summary		
HCM 2000 Control Delay	12.6	HCM 2000 Level of Service
HCM 2000 Volume to Capacity ratio	0.58	B
Actuated Cycle Length (s)	61.4	Sum of lost time (s)
Intersection Capacity Utilization	52.9%	18.0
Analysis Period (min)	15	ICU Level of Service
		A

c Critical Lane Group

2022 Weekday Evening Peak Hour
1: King St/Chestnut St & Route 140

01/18/2022



Lane Group	EBL	EBT	EBR	WBL	WBT	WBR	NEL	NET	NER	SWL	SWT	SWR
Lane Configurations												
Traffic Volume (vph)	152	420	42	363	437	47	31	282	301	28	313	120
Future Volume (vph)	152	420	42	363	437	47	31	282	301	28	313	120
Ideal Flow (vphpl)	1900	1900	1900	1900	1900	1900	1900	1900	1900	1900	1900	1900
Lane Width (ft)	12	11	11	11	11	11	11	11	11	16	16	16
Storage Length (ft)	100		50	165		50	0		80	0		0
Storage Lanes	1		0	1		0	0		1	0		0
Taper Length (ft)	25			25			25			25		
Right Turn on Red			Yes			Yes			Yes			Yes
Link Speed (mph)		30			30			30				30
Link Distance (ft)		639			1214			457				724
Travel Time (s)		14.5			27.6			10.4				16.5
Peak Hour Factor	0.93	0.93	0.93	0.93	0.93	0.93	0.91	0.91	0.91	0.81	0.81	0.81
Heavy Vehicles (%)	0%	0%	0%	0%	0%	0%	4%	1%	1%	0%	1%	0%
Shared Lane Traffic (%)												
Lane Group Flow (vph)	163	497	0	390	521	0	0	344	331	0	569	0
Turn Type	pm+pt	NA		pm+pt	NA		Perm	NA	pm+ov	Perm	NA	
Protected Phases	5	2		1	6			8	1			4
Permitted Phases	2			6			8		8	4		
Detector Phase	5	2		1	6		8	8	1	4		4
Switch Phase												
Minimum Initial (s)	6.0	6.0		6.0	6.0		6.0	6.0	6.0	6.0		6.0
Minimum Split (s)	11.0	21.0		11.0	21.0		21.0	21.0	11.0	21.0		21.0
Total Split (s)	20.0	40.0		20.0	40.0		35.0	35.0	20.0	35.0		35.0
Total Split (%)	17.1%	34.2%		17.1%	34.2%		29.9%	29.9%	17.1%	29.9%		29.9%
Yellow Time (s)	3.0	3.0		3.0	3.0		3.0	3.0	3.0	3.0		3.0
All-Red Time (s)	2.0	2.0		2.0	2.0		2.0	2.0	2.0	2.0		2.0
Lost Time Adjust (s)	-1.0	-1.0		-1.0	-1.0			-1.0	-1.0			-1.0
Total Lost Time (s)	4.0	4.0		4.0	4.0			4.0	4.0			4.0
Lead/Lag	Lead	Lag		Lead	Lag				Lead			
Lead-Lag Optimize?	Yes	Yes		Yes	Yes				Yes			
Recall Mode	None	None		None	None		None	None	None	None		None
v/c Ratio	0.46	0.82		1.00	0.75			0.69	0.35			0.93
Control Delay	16.7	42.3		72.4	34.5			38.4	6.5			55.6
Queue Delay	0.0	0.0		0.0	0.0			0.0	0.0			0.0
Total Delay	16.7	42.3		72.4	34.5			38.4	6.5			55.6
Queue Length 50th (ft)	41	250		164	239			173	30			312
Queue Length 95th (ft)	110	#542		#497	#583			#407	119			#603
Internal Link Dist (ft)		559			1134			377				644
Turn Bay Length (ft)	100			165					80			
Base Capacity (vph)	452	699		389	726			500	943			611
Starvation Cap Reductn	0	0		0	0			0	0			0
Spillback Cap Reductn	0	0		0	0			0	0			0
Storage Cap Reductn	0	0		0	0			0	0			0
Reduced v/c Ratio	0.36	0.71		1.00	0.72			0.69	0.35			0.93

Intersection Summary

Area Type: Other
Cycle Length: 117

Lane Group	Ø9
Lane Configurations	
Traffic Volume (vph)	
Future Volume (vph)	
Ideal Flow (vphpl)	
Lane Width (ft)	
Storage Length (ft)	
Storage Lanes	
Taper Length (ft)	
Right Turn on Red	
Link Speed (mph)	
Link Distance (ft)	
Travel Time (s)	
Peak Hour Factor	
Heavy Vehicles (%)	
Shared Lane Traffic (%)	
Lane Group Flow (vph)	
Turn Type	
Protected Phases	9
Permitted Phases	
Detector Phase	
Switch Phase	
Minimum Initial (s)	4.0
Minimum Split (s)	21.0
Total Split (s)	22.0
Total Split (%)	19%
Yellow Time (s)	3.0
All-Red Time (s)	2.0
Lost Time Adjust (s)	
Total Lost Time (s)	
Lead/Lag	
Lead-Lag Optimize?	
Recall Mode	None
v/c Ratio	
Control Delay	
Queue Delay	
Total Delay	
Queue Length 50th (ft)	
Queue Length 95th (ft)	
Internal Link Dist (ft)	
Turn Bay Length (ft)	
Base Capacity (vph)	
Starvation Cap Reductn	
Spillback Cap Reductn	
Storage Cap Reductn	
Reduced v/c Ratio	
Intersection Summary	

2022 Weekday Evening Peak Hour
 1: King St/Chestnut St & Route 140

01/18/2022

Actuated Cycle Length: 94.7







Natural Cycle: 140

Control Type: Actuated-Uncoordinated

95th percentile volume exceeds capacity, queue may be longer.

Queue shown is maximum after two cycles.

Splits and Phases: 1: King St/Chestnut St & Route 140

 Ø4	 Ø1	 Ø2	 Ø9
35 s	20 s	40 s	22 s
 Ø8	 Ø5	 Ø6	
35 s	20 s	40 s	

2022 Weekday Evening Peak Hour
1: King St/Chestnut St & Route 140

01/18/2022

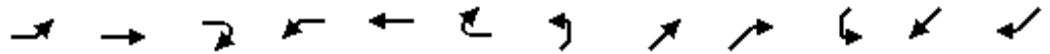

Movement	EBL	EBT	EBR	WBL	WBT	WBR	NEL	NET	NER	SWL	SWT	SWR
Lane Configurations												
Traffic Volume (vph)	152	420	42	363	437	47	31	282	301	28	313	120
Future Volume (vph)	152	420	42	363	437	47	31	282	301	28	313	120
Ideal Flow (vphpl)	1900	1900	1900	1900	1900	1900	1900	1900	1900	1900	1900	1900
Lane Width	12	11	11	11	11	11	11	11	11	16	16	16
Total Lost time (s)	4.0	4.0		4.0	4.0			4.0	4.0		4.0	
Lane Util. Factor	1.00	1.00		1.00	1.00			1.00	1.00		1.00	
Frt	1.00	0.99		1.00	0.99			1.00	0.85		0.96	
Flt Protected	0.95	1.00		0.95	1.00			1.00	1.00		1.00	
Satd. Flow (prot)	1805	1812		1745	1810			1804	1546		2057	
Flt Permitted	0.23	1.00		0.13	1.00			0.83	1.00		0.88	
Satd. Flow (perm)	431	1812		246	1810			1508	1546		1811	
Peak-hour factor, PHF	0.93	0.93	0.93	0.93	0.93	0.93	0.91	0.91	0.91	0.81	0.81	0.81
Adj. Flow (vph)	163	452	45	390	470	51	34	310	331	35	386	148
RTOR Reduction (vph)	0	3	0	0	3	0	0	0	114	0	10	0
Lane Group Flow (vph)	163	494	0	390	518	0	0	344	217	0	559	0
Heavy Vehicles (%)	0%	0%	0%	0%	0%	0%	4%	1%	1%	0%	1%	0%
Turn Type	pm+pt	NA		pm+pt	NA		Perm	NA	pm+ov	Perm	NA	
Protected Phases	5	2		1	6			8	1		4	
Permitted Phases	2			6			8		8	4		
Actuated Green, G (s)	40.7	30.5		50.7	35.5			30.4	45.6		30.4	
Effective Green, g (s)	42.7	31.5		51.7	36.5			31.4	47.6		31.4	
Actuated g/C Ratio	0.43	0.32		0.52	0.37			0.32	0.48		0.32	
Clearance Time (s)	5.0	5.0		5.0	5.0			5.0	5.0		5.0	
Vehicle Extension (s)	3.0	3.0		3.0	3.0			3.0	3.0		3.0	
Lane Grp Cap (vph)	342	578		374	669			479	808		576	
v/s Ratio Prot	0.05	0.27		c0.17	0.29				0.04			
v/s Ratio Perm	0.15			c0.37				0.23	0.10		c0.31	
v/c Ratio	0.48	0.86		1.04	0.77			0.72	0.27		0.97	
Uniform Delay, d1	19.1	31.5		27.0	27.5			29.7	15.2		33.2	
Progression Factor	1.00	1.00		1.00	1.00			1.00	1.00		1.00	
Incremental Delay, d2	1.0	11.8		58.1	5.6			5.1	0.2		29.9	
Delay (s)	20.2	43.3		85.2	33.0			34.8	15.4		63.1	
Level of Service	C	D		F	C			C	B		E	
Approach Delay (s)		37.6			55.3			25.3			63.1	
Approach LOS		D			E			C			E	

Intersection Summary

HCM 2000 Control Delay	45.5	HCM 2000 Level of Service	D
HCM 2000 Volume to Capacity ratio	1.01		
Actuated Cycle Length (s)	98.7	Sum of lost time (s)	17.0
Intersection Capacity Utilization	100.0%	ICU Level of Service	F
Analysis Period (min)	15		

c Critical Lane Group

2022 Weekday Evening Peak Hour
 2: CVS Dwy/Horace Mann Plaza Dwy & Route 140

01/18/2022



Lane Group	EBL	EBT	EBR	WBL	WBT	WBR	NBL	NBT	NBR	SBL	SBT	SBR
Lane Configurations												
Traffic Volume (vph)	192	549	46	19	674	137	34	18	33	126	16	205
Future Volume (vph)	192	549	46	19	674	137	34	18	33	126	16	205
Ideal Flow (vphpl)	1900	1900	1900	1900	1900	1900	1900	1900	1900	1900	1900	1900
Lane Width (ft)	10	11	11	11	11	11	11	11	11	13	13	12
Storage Length (ft)	160		50	100		150	0		26	50		0
Storage Lanes	1		1	1		1	0		1	0		1
Taper Length (ft)	25			25			25			25		
Right Turn on Red			Yes			Yes			Yes			Yes
Link Speed (mph)		30			30			30				30
Link Distance (ft)		1214			922			320				157
Travel Time (s)		27.6			21.0			7.3				3.6
Peak Hour Factor	0.94	0.94	0.94	0.91	0.91	0.91	0.95	0.95	0.95	0.96	0.96	0.96
Heavy Vehicles (%)	0%	1%	0%	0%	0%	0%	0%	0%	0%	0%	0%	0%
Shared Lane Traffic (%)												
Lane Group Flow (vph)	204	584	49	21	741	151	0	55	35	0	148	214
Turn Type	pm+pt	NA	custom	pm+pt	NA	custom	Perm	NA	Perm	Perm	NA	pm+ov
Protected Phases	5	2	2	1	6	6		8			4	5
Permitted Phases	2		2	6		6	8		8	4		4
Detector Phase	5	2	2	1	6	6	8	8	8	4	4	5
Switch Phase												
Minimum Initial (s)	5.0	10.0	10.0	5.0	10.0	10.0	5.0	5.0	5.0	5.0	5.0	5.0
Minimum Split (s)	10.0	15.0	15.0	10.0	15.0	15.0	9.0	9.0	9.0	9.0	9.0	10.0
Total Split (s)	20.0	44.0	44.0	20.0	44.0	44.0	24.0	24.0	24.0	24.0	24.0	20.0
Total Split (%)	18.2%	40.0%	40.0%	18.2%	40.0%	40.0%	21.8%	21.8%	21.8%	21.8%	21.8%	18.2%
Yellow Time (s)	4.0	4.0	4.0	4.0	4.0	4.0	3.0	3.0	3.0	3.0	3.0	4.0
All-Red Time (s)	1.0	1.0	1.0	1.0	1.0	1.0	1.0	1.0	1.0	1.0	1.0	1.0
Lost Time Adjust (s)	-1.0	-1.0	-1.0	-1.0	-1.0	-1.0		0.0	0.0		0.0	0.0
Total Lost Time (s)	4.0	4.0	4.0	4.0	4.0	4.0		4.0	4.0		4.0	5.0
Lead/Lag	Lead	Lag	Lag	Lead	Lag	Lag						Lead
Lead-Lag Optimize?												
Recall Mode	None	None	None	None	None	None	None	None	None	None	None	None
v/c Ratio	0.52	0.49	0.05	0.04	0.81	0.18		0.28	0.10		0.69	0.31
Control Delay	14.0	13.0	0.1	8.0	29.2	6.7		36.8	0.6		51.4	3.5
Queue Delay	0.0	0.0	0.0	0.0	0.0	0.0		0.0	0.0		0.0	0.0
Total Delay	14.0	13.0	0.1	8.0	29.2	6.7		36.8	0.6		51.4	3.5
Queue Length 50th (ft)	24	87	0	2	281	10		24	0		69	0
Queue Length 95th (ft)	137	459	0	18	#818	63		72	0		165	33
Internal Link Dist (ft)		1134			842			240			77	
Turn Bay Length (ft)	160		50	100		150			26			
Base Capacity (vph)	456	1204	1070	722	917	833		314	478		348	749
Starvation Cap Reductn	0	0	0	0	0	0		0	0		0	0
Spillback Cap Reductn	0	0	0	0	0	0		0	0		0	0
Storage Cap Reductn	0	0	0	0	0	0		0	0		0	0
Reduced v/c Ratio	0.45	0.49	0.05	0.03	0.81	0.18		0.18	0.07		0.43	0.29

Intersection Summary

Area Type: Other
 Cycle Length: 110

Lane Group	Ø9
Lane Configurations	
Traffic Volume (vph)	
Future Volume (vph)	
Ideal Flow (vphpl)	
Lane Width (ft)	
Storage Length (ft)	
Storage Lanes	
Taper Length (ft)	
Right Turn on Red	
Link Speed (mph)	
Link Distance (ft)	
Travel Time (s)	
Peak Hour Factor	
Heavy Vehicles (%)	
Shared Lane Traffic (%)	
Lane Group Flow (vph)	
Turn Type	
Protected Phases	9
Permitted Phases	
Detector Phase	
Switch Phase	
Minimum Initial (s)	4.0
Minimum Split (s)	21.0
Total Split (s)	22.0
Total Split (%)	20%
Yellow Time (s)	3.0
All-Red Time (s)	2.0
Lost Time Adjust (s)	
Total Lost Time (s)	
Lead/Lag	
Lead-Lag Optimize?	
Recall Mode	None
v/c Ratio	
Control Delay	
Queue Delay	
Total Delay	
Queue Length 50th (ft)	
Queue Length 95th (ft)	
Internal Link Dist (ft)	
Turn Bay Length (ft)	
Base Capacity (vph)	
Starvation Cap Reductn	
Spillback Cap Reductn	
Storage Cap Reductn	
Reduced v/c Ratio	
Intersection Summary	

2022 Weekday Evening Peak Hour
 2: CVS Dwy/Horace Mann Plaza Dwy & Route 140

01/18/2022

Actuated Cycle Length: 82.2





Natural Cycle: 90

Control Type: Actuated-Uncoordinated

95th percentile volume exceeds capacity, queue may be longer.

Queue shown is maximum after two cycles.

Splits and Phases: 2: CVS Dwy/Horace Mann Plaza Dwy & Route 140

 01	 02	 04	 09
20 s	44 s	24 s	22 s
 05	 06	 08	
20 s	44 s	24 s	

2022 Weekday Evening Peak Hour
2: CVS Dwy/Horace Mann Plaza Dwy & Route 140

01/18/2022



Movement	EBL	EBT	EBR	WBL	WBT	WBR	NBL	NBT	NBR	SBL	SBT	SBR
Lane Configurations												
Traffic Volume (vph)	192	549	46	19	674	137	34	18	33	126	16	205
Future Volume (vph)	192	549	46	19	674	137	34	18	33	126	16	205
Ideal Flow (vphpl)	1900	1900	1900	1900	1900	1900	1900	1900	1900	1900	1900	1900
Lane Width	10	11	11	11	11	11	11	11	11	13	13	12
Total Lost time (s)	4.0	4.0	4.0	4.0	4.0	4.0		4.0	4.0		4.0	5.0
Lane Util. Factor	1.00	1.00	1.00	1.00	1.00	1.00		1.00	1.00		1.00	1.00
Frt	1.00	1.00	0.85	1.00	1.00	0.85		1.00	0.85		1.00	0.85
Flt Protected	0.95	1.00	1.00	0.95	1.00	1.00		0.97	1.00		0.96	1.00
Satd. Flow (prot)	1685	1818	1561	1745	1837	1561		1778	1561		1880	1615
Flt Permitted	0.13	1.00	1.00	0.42	1.00	1.00		0.69	1.00		0.71	1.00
Satd. Flow (perm)	236	1818	1561	766	1837	1561		1262	1561		1397	1615
Peak-hour factor, PHF	0.94	0.94	0.94	0.91	0.91	0.91	0.95	0.95	0.95	0.96	0.96	0.96
Adj. Flow (vph)	204	584	49	21	741	151	36	19	35	131	17	214
RTOR Reduction (vph)	0	0	19	0	0	55	0	0	30	0	0	155
Lane Group Flow (vph)	204	584	30	21	741	96	0	55	5	0	148	59
Heavy Vehicles (%)	0%	1%	0%	0%	0%	0%	0%	0%	0%	0%	0%	0%
Turn Type	pm+pt	NA	custom	pm+pt	NA	custom	Perm	NA	Perm	Perm	NA	pm+ov
Protected Phases	5	2	2	1	6	6		8			4	5
Permitted Phases	2		2	6		6	8		8	4		4
Actuated Green, G (s)	60.3	53.4	53.4	45.2	43.3	43.3		12.7	12.7		12.7	24.7
Effective Green, g (s)	61.3	54.4	54.4	47.2	44.3	44.3		12.7	12.7		12.7	24.7
Actuated g/C Ratio	0.69	0.61	0.61	0.53	0.50	0.50		0.14	0.14		0.14	0.28
Clearance Time (s)	5.0	5.0	5.0	5.0	5.0	5.0		4.0	4.0		4.0	5.0
Vehicle Extension (s)	2.0	2.0	2.0	2.0	2.0	2.0		2.0	2.0		2.0	2.0
Lane Grp Cap (vph)	372	1106	949	436	910	773		179	221		198	446
v/s Ratio Prot	c0.08	0.32	0.02	0.00	c0.40	0.06						0.02
v/s Ratio Perm	0.30			0.02				0.04	0.00		c0.11	0.02
v/c Ratio	0.55	0.53	0.03	0.05	0.81	0.12		0.31	0.02		0.75	0.13
Uniform Delay, d1	13.0	10.1	7.0	10.1	19.1	12.1		34.4	33.0		36.8	24.3
Progression Factor	1.00	1.00	1.00	1.00	1.00	1.00		1.00	1.00		1.00	1.00
Incremental Delay, d2	0.9	0.2	0.0	0.0	5.4	0.0		0.4	0.0		12.6	0.0
Delay (s)	13.9	10.3	7.0	10.1	24.4	12.1		34.8	33.0		49.4	24.4
Level of Service	B	B	A	B	C	B		C	C		D	C
Approach Delay (s)		11.0			22.1			34.1			34.6	
Approach LOS		B			C			C			C	

Intersection Summary

HCM 2000 Control Delay	20.4	HCM 2000 Level of Service	C
HCM 2000 Volume to Capacity ratio	0.74		
Actuated Cycle Length (s)	89.4	Sum of lost time (s)	18.0
Intersection Capacity Utilization	70.6%	ICU Level of Service	C
Analysis Period (min)	15		

c Critical Lane Group

2029 No-Build



2029 No-Build Weekday Morning Peak Hour
1: King St/Chestnut St & Route 140

01/18/2022

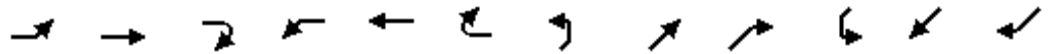

Lane Group	EBL	EBT	EBR	WBL	WBT	WBR	NEL	NET	NER	SWL	SWT	SWR
Lane Configurations												
Traffic Volume (vph)	84	372	35	242	308	62	28	367	342	24	271	106
Future Volume (vph)	84	372	35	242	308	62	28	367	342	24	271	106
Ideal Flow (vphpl)	1900	1900	1900	1900	1900	1900	1900	1900	1900	1900	1900	1900
Lane Width (ft)	12	11	11	11	11	11	11	11	11	16	16	16
Storage Length (ft)	100		50	165		50	0		80	0		0
Storage Lanes	1		0	1		0	0		1	0		0
Taper Length (ft)	25			25			25			25		
Right Turn on Red			Yes			Yes			Yes			Yes
Link Speed (mph)		30			30			30				30
Link Distance (ft)		639			1214			457				724
Travel Time (s)		14.5			27.6			10.4				16.5
Peak Hour Factor	0.92	0.92	0.92	0.99	0.99	0.99	0.89	0.89	0.89	0.90	0.90	0.90
Heavy Vehicles (%)	6%	2%	0%	1%	2%	0%	0%	2%	1%	11%	2%	3%
Shared Lane Traffic (%)												
Lane Group Flow (vph)	91	442	0	244	374	0	0	443	384	0	446	0
Turn Type	pm+pt	NA		pm+pt	NA		Perm	NA	pm+ov	Perm	NA	
Protected Phases	5	2		1	6			8	1			4
Permitted Phases	2			6			8		8	4		
Detector Phase	5	2		1	6		8	8	1	4		4
Switch Phase												
Minimum Initial (s)	6.0	6.0		6.0	6.0		6.0	6.0	6.0	6.0		6.0
Minimum Split (s)	11.0	21.0		11.0	21.0		21.0	21.0	11.0	21.0		21.0
Total Split (s)	20.0	40.0		20.0	40.0		35.0	35.0	20.0	35.0		35.0
Total Split (%)	17.1%	34.2%		17.1%	34.2%		29.9%	29.9%	17.1%	29.9%		29.9%
Yellow Time (s)	3.0	3.0		3.0	3.0		3.0	3.0	3.0	3.0		3.0
All-Red Time (s)	2.0	2.0		2.0	2.0		2.0	2.0	2.0	2.0		2.0
Lost Time Adjust (s)	-1.0	-1.0		-1.0	-1.0			-1.0	-1.0			-1.0
Total Lost Time (s)	4.0	4.0		4.0	4.0			4.0	4.0			4.0
Lead/Lag	Lead	Lag		Lead	Lag				Lead			
Lead-Lag Optimize?	Yes	Yes		Yes	Yes				Yes			
Recall Mode	None	None		None	None		None	None	None	None		None
v/c Ratio	0.22	0.79		0.65	0.54			0.72	0.40			0.73
Control Delay	13.8	39.9		22.4	26.1			36.0	8.2			35.5
Queue Delay	0.0	0.0		0.0	0.0			0.0	0.0			0.0
Total Delay	13.8	39.9		22.4	26.1			36.0	8.2			35.5
Queue Length 50th (ft)	22	202		65	148			195	43			191
Queue Length 95th (ft)	66	#456		171	332			#528	172			#537
Internal Link Dist (ft)		559			1134			377				644
Turn Bay Length (ft)	100			165					80			
Base Capacity (vph)	551	748		428	763			613	998			609
Starvation Cap Reductn	0	0		0	0			0	0			0
Spillback Cap Reductn	0	0		0	0			0	0			0
Storage Cap Reductn	0	0		0	0			0	0			0
Reduced v/c Ratio	0.17	0.59		0.57	0.49			0.72	0.38			0.73

Intersection Summary

Area Type: Other
Cycle Length: 117

2029 No-Build Weekday Morning Peak Hour
 1: King St/Chestnut St & Route 140

01/18/2022

Lane Group	Ø9
Lane Configurations	
Traffic Volume (vph)	
Future Volume (vph)	
Ideal Flow (vphpl)	
Lane Width (ft)	
Storage Length (ft)	
Storage Lanes	
Taper Length (ft)	
Right Turn on Red	
Link Speed (mph)	
Link Distance (ft)	
Travel Time (s)	
Peak Hour Factor	
Heavy Vehicles (%)	
Shared Lane Traffic (%)	
Lane Group Flow (vph)	
Turn Type	
Protected Phases	9
Permitted Phases	
Detector Phase	
Switch Phase	
Minimum Initial (s)	4.0
Minimum Split (s)	21.0
Total Split (s)	22.0
Total Split (%)	19%
Yellow Time (s)	3.0
All-Red Time (s)	2.0
Lost Time Adjust (s)	
Total Lost Time (s)	
Lead/Lag	
Lead-Lag Optimize?	
Recall Mode	None
v/c Ratio	
Control Delay	
Queue Delay	
Total Delay	
Queue Length 50th (ft)	
Queue Length 95th (ft)	
Internal Link Dist (ft)	
Turn Bay Length (ft)	
Base Capacity (vph)	
Starvation Cap Reductn	
Spillback Cap Reductn	
Storage Cap Reductn	
Reduced v/c Ratio	
Intersection Summary	

2029 No-Build Weekday Morning Peak Hour
 1: King St/Chestnut St & Route 140

01/18/2022

Actuated Cycle Length: 88.3







Natural Cycle: 90

Control Type: Actuated-Uncoordinated

95th percentile volume exceeds capacity, queue may be longer.

Queue shown is maximum after two cycles.

Splits and Phases: 1: King St/Chestnut St & Route 140

 Ø4	 Ø1	 Ø2	 Ø9
35 s	20 s	40 s	22 s
 Ø8	 Ø5	 Ø6	
35 s	20 s	40 s	

2029 No-Build Weekday Morning Peak Hour
1: King St/Chestnut St & Route 140

01/18/2022

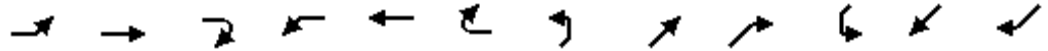

Movement	EBL	EBT	EBR	WBL	WBT	WBR	NEL	NET	NER	SWL	SWT	SWR
Lane Configurations												
Traffic Volume (vph)	84	372	35	242	308	62	28	367	342	24	271	106
Future Volume (vph)	84	372	35	242	308	62	28	367	342	24	271	106
Ideal Flow (vphpl)	1900	1900	1900	1900	1900	1900	1900	1900	1900	1900	1900	1900
Lane Width	12	11	11	11	11	11	11	11	11	16	16	16
Total Lost time (s)	4.0	4.0		4.0	4.0			4.0	4.0		4.0	
Lane Util. Factor	1.00	1.00		1.00	1.00			1.00	1.00		1.00	
Frt	1.00	0.99		1.00	0.97			1.00	0.85		0.96	
Flt Protected	0.95	1.00		0.95	1.00			1.00	1.00		1.00	
Satd. Flow (prot)	1703	1780		1728	1761			1797	1546		2014	
Flt Permitted	0.43	1.00		0.18	1.00			0.94	1.00		0.82	
Satd. Flow (perm)	766	1780		332	1761			1699	1546		1662	
Peak-hour factor, PHF	0.92	0.92	0.92	0.99	0.99	0.99	0.89	0.89	0.89	0.90	0.90	0.90
Adj. Flow (vph)	91	404	38	244	311	63	31	412	384	27	301	118
RTOR Reduction (vph)	0	3	0	0	6	0	0	0	103	0	10	0
Lane Group Flow (vph)	91	439	0	244	368	0	0	443	281	0	436	0
Heavy Vehicles (%)	6%	2%	0%	1%	2%	0%	0%	2%	1%	11%	2%	3%
Turn Type	pm+pt	NA		pm+pt	NA		Perm	NA	pm+ov	Perm	NA	
Protected Phases	5	2		1	6			8	1		4	
Permitted Phases	2			6			8		8	4		
Actuated Green, G (s)	34.6	27.8		45.1	33.3			30.8	43.1		30.8	
Effective Green, g (s)	36.6	28.8		46.1	34.3			31.8	45.1		31.8	
Actuated g/C Ratio	0.39	0.31		0.49	0.37			0.34	0.48		0.34	
Clearance Time (s)	5.0	5.0		5.0	5.0			5.0	5.0		5.0	
Vehicle Extension (s)	3.0	3.0		3.0	3.0			3.0	3.0		3.0	
Lane Grp Cap (vph)	378	549		363	647			579	813		566	
v/s Ratio Prot	0.02	c0.25		c0.10	0.21				0.05			
v/s Ratio Perm	0.07			0.24				0.26	0.13		c0.26	
v/c Ratio	0.24	0.80		0.67	0.57			0.77	0.35		0.77	
Uniform Delay, d1	18.4	29.6		17.1	23.6			27.4	14.9		27.5	
Progression Factor	1.00	1.00		1.00	1.00			1.00	1.00		1.00	
Incremental Delay, d2	0.3	8.2		4.8	1.2			6.0	0.3		6.4	
Delay (s)	18.7	37.8		22.0	24.7			33.4	15.2		33.9	
Level of Service	B	D		C	C			C	B		C	
Approach Delay (s)		34.5			23.6			25.0			33.9	
Approach LOS		C			C			C			C	

Intersection Summary

HCM 2000 Control Delay	28.4	HCM 2000 Level of Service	C
HCM 2000 Volume to Capacity ratio	0.74		
Actuated Cycle Length (s)	93.3	Sum of lost time (s)	17.0
Intersection Capacity Utilization	86.3%	ICU Level of Service	E
Analysis Period (min)	15		

c Critical Lane Group

2029 No-Build Weekday Morning Peak Hour
 2: CVS Dwy/Horace Mann Plaza Dwy & Route 140

01/18/2022



Lane Group	EBL	EBT	EBR	WBL	WBT	WBR	NBL	NBT	NBR	SBL	SBT	SBR
Lane Configurations												
Traffic Volume (vph)	98	618	20	8	519	59	20	4	13	76	5	65
Future Volume (vph)	98	618	20	8	519	59	20	4	13	76	5	65
Ideal Flow (vphpl)	1900	1900	1900	1900	1900	1900	1900	1900	1900	1900	1900	1900
Lane Width (ft)	10	11	11	11	11	11	11	11	11	13	13	12
Storage Length (ft)	160		50	100		150	0		26	50		0
Storage Lanes	1		1	1		1	0		1	0		1
Taper Length (ft)	25			25			25			25		
Right Turn on Red			Yes			Yes			Yes			Yes
Link Speed (mph)		30			30			30				30
Link Distance (ft)		1214			741			320				157
Travel Time (s)		27.6			16.8			7.3				3.6
Peak Hour Factor	0.87	0.87	0.87	0.85	0.85	0.85	0.82	0.82	0.82	0.85	0.85	0.85
Heavy Vehicles (%)	0%	2%	0%	0%	0%	0%	0%	0%	0%	0%	0%	0%
Shared Lane Traffic (%)												
Lane Group Flow (vph)	113	710	23	9	611	69	0	29	16	0	95	76
Turn Type	pm+pt	NA	custom	pm+pt	NA	custom	Perm	NA	Perm	Perm	NA	pm+ov
Protected Phases	5	2	2	1	6	6		8			4	5
Permitted Phases	2		2	6		6	8		8	4		4
Detector Phase	5	2	2	1	6	6	8	8	8	4	4	5
Switch Phase												
Minimum Initial (s)	5.0	10.0	10.0	5.0	10.0	10.0	5.0	5.0	5.0	5.0	5.0	5.0
Minimum Split (s)	10.0	15.0	15.0	10.0	15.0	15.0	9.0	9.0	9.0	9.0	9.0	10.0
Total Split (s)	20.0	44.0	44.0	20.0	44.0	44.0	24.0	24.0	24.0	24.0	24.0	20.0
Total Split (%)	18.2%	40.0%	40.0%	18.2%	40.0%	40.0%	21.8%	21.8%	21.8%	21.8%	21.8%	18.2%
Yellow Time (s)	4.0	4.0	4.0	4.0	4.0	4.0	3.0	3.0	3.0	3.0	3.0	4.0
All-Red Time (s)	1.0	1.0	1.0	1.0	1.0	1.0	1.0	1.0	1.0	1.0	1.0	1.0
Lost Time Adjust (s)	-1.0	-1.0	-1.0	-1.0	-1.0	-1.0		0.0	0.0		0.0	0.0
Total Lost Time (s)	4.0	4.0	4.0	4.0	4.0	4.0		4.0	4.0		4.0	5.0
Lead/Lag	Lead	Lag	Lag	Lead	Lag	Lag						Lead
Lead-Lag Optimize?												
Recall Mode	None	None	None	None	None	None	None	None	None	None	None	None
v/c Ratio	0.23	0.55	0.02	0.02	0.57	0.07		0.15	0.05		0.46	0.15
Control Delay	7.0	12.6	0.1	7.1	18.3	1.5		31.0	0.3		36.9	4.7
Queue Delay	0.0	0.0	0.0	0.0	0.0	0.0		0.0	0.0		0.0	0.0
Total Delay	7.0	12.6	0.1	7.1	18.3	1.5		31.0	0.3		36.9	4.7
Queue Length 50th (ft)	9	90	0	1	148	0		9	0		30	0
Queue Length 95th (ft)	58	#593	0	9	#470	7		39	0		101	19
Internal Link Dist (ft)		1134			661			240			77	
Turn Bay Length (ft)	160		50	100		150			26			
Base Capacity (vph)	658	1302	1158	718	1266	1110		445	603		473	714
Starvation Cap Reductn	0	0	0	0	0	0		0	0		0	0
Spillback Cap Reductn	0	0	0	0	0	0		0	0		0	0
Storage Cap Reductn	0	0	0	0	0	0		0	0		0	0
Reduced v/c Ratio	0.17	0.55	0.02	0.01	0.48	0.06		0.07	0.03		0.20	0.11

Intersection Summary

Area Type: Other
 Cycle Length: 110

Lane Group	Ø9
Lane Configurations	
Traffic Volume (vph)	
Future Volume (vph)	
Ideal Flow (vphpl)	
Lane Width (ft)	
Storage Length (ft)	
Storage Lanes	
Taper Length (ft)	
Right Turn on Red	
Link Speed (mph)	
Link Distance (ft)	
Travel Time (s)	
Peak Hour Factor	
Heavy Vehicles (%)	
Shared Lane Traffic (%)	
Lane Group Flow (vph)	
Turn Type	
Protected Phases	9
Permitted Phases	
Detector Phase	
Switch Phase	
Minimum Initial (s)	4.0
Minimum Split (s)	21.0
Total Split (s)	22.0
Total Split (%)	20%
Yellow Time (s)	3.0
All-Red Time (s)	2.0
Lost Time Adjust (s)	
Total Lost Time (s)	
Lead/Lag	
Lead-Lag Optimize?	
Recall Mode	None
v/c Ratio	
Control Delay	
Queue Delay	
Total Delay	
Queue Length 50th (ft)	
Queue Length 95th (ft)	
Internal Link Dist (ft)	
Turn Bay Length (ft)	
Base Capacity (vph)	
Starvation Cap Reductn	
Spillback Cap Reductn	
Storage Cap Reductn	
Reduced v/c Ratio	
Intersection Summary	

2029 No-Build Weekday Morning Peak Hour
 2: CVS Dwy/Horace Mann Plaza Dwy & Route 140

01/18/2022

Actuated Cycle Length: 64.4

Natural Cycle: 80

Control Type: Actuated-Uncoordinated

95th percentile volume exceeds capacity, queue may be longer.

Queue shown is maximum after two cycles.

Splits and Phases: 2: CVS Dwy/Horace Mann Plaza Dwy & Route 140

 Ø1	 Ø2	 Ø4	 Ø9
20 s	44 s	24 s	22 s
 Ø5	 Ø6	 Ø8	
20 s	44 s	24 s	

2029 No-Build Weekday Morning Peak Hour
2: CVS Dwy/Horace Mann Plaza Dwy & Route 140

01/18/2022



Movement	EBL	EBT	EBR	WBL	WBT	WBR	NBL	NBT	NBR	SBL	SBT	SBR
Lane Configurations												
Traffic Volume (vph)	98	618	20	8	519	59	20	4	13	76	5	65
Future Volume (vph)	98	618	20	8	519	59	20	4	13	76	5	65
Ideal Flow (vphpl)	1900	1900	1900	1900	1900	1900	1900	1900	1900	1900	1900	1900
Lane Width	10	11	11	11	11	11	11	11	11	13	13	12
Total Lost time (s)	4.0	4.0	4.0	4.0	4.0	4.0		4.0	4.0		4.0	5.0
Lane Util. Factor	1.00	1.00	1.00	1.00	1.00	1.00		1.00	1.00		1.00	1.00
Frt	1.00	1.00	0.85	1.00	1.00	0.85		1.00	0.85		1.00	0.85
Flt Protected	0.95	1.00	1.00	0.95	1.00	1.00		0.96	1.00		0.96	1.00
Satd. Flow (prot)	1685	1801	1561	1745	1837	1561		1764	1561		1875	1615
Flt Permitted	0.26	1.00	1.00	0.30	1.00	1.00		0.72	1.00		0.72	1.00
Satd. Flow (perm)	457	1801	1561	557	1837	1561		1326	1561		1410	1615
Peak-hour factor, PHF	0.87	0.87	0.87	0.85	0.85	0.85	0.82	0.82	0.82	0.85	0.85	0.85
Adj. Flow (vph)	113	710	23	9	611	69	24	5	16	89	6	76
RTOR Reduction (vph)	0	0	9	0	0	32	0	0	14	0	0	61
Lane Group Flow (vph)	113	710	14	9	611	37	0	29	2	0	95	15
Heavy Vehicles (%)	0%	2%	0%	0%	0%	0%	0%	0%	0%	0%	0%	0%
Turn Type	pm+pt	NA	custom	pm+pt	NA	custom	Perm	NA	Perm	Perm	NA	pm+ov
Protected Phases	5	2	2	1	6	6		8			4	5
Permitted Phases	2		2	6		6	8		8	4		4
Actuated Green, G (s)	49.6	43.9	43.9	39.1	38.4	38.4		8.0	8.0		8.0	14.2
Effective Green, g (s)	50.6	44.9	44.9	41.1	39.4	39.4		8.0	8.0		8.0	14.2
Actuated g/C Ratio	0.69	0.61	0.61	0.56	0.54	0.54		0.11	0.11		0.11	0.19
Clearance Time (s)	5.0	5.0	5.0	5.0	5.0	5.0		4.0	4.0		4.0	5.0
Vehicle Extension (s)	2.0	2.0	2.0	2.0	2.0	2.0		2.0	2.0		2.0	2.0
Lane Grp Cap (vph)	434	1098	952	338	983	835		144	169		153	311
v/s Ratio Prot	c0.03	c0.39	0.01	0.00	0.33	0.02						0.00
v/s Ratio Perm	0.15			0.01				0.02	0.00		c0.07	0.01
v/c Ratio	0.26	0.65	0.01	0.03	0.62	0.04		0.20	0.01		0.62	0.05
Uniform Delay, d1	6.3	9.2	5.6	7.8	11.9	8.1		29.9	29.3		31.4	24.2
Progression Factor	1.00	1.00	1.00	1.00	1.00	1.00		1.00	1.00		1.00	1.00
Incremental Delay, d2	0.1	1.0	0.0	0.0	0.9	0.0		0.3	0.0		5.5	0.0
Delay (s)	6.4	10.2	5.6	7.8	12.8	8.1		30.1	29.3		36.9	24.2
Level of Service	A	B	A	A	B	A		C	C		D	C
Approach Delay (s)		9.6			12.3			29.8			31.2	
Approach LOS		A			B			C			C	

Intersection Summary

HCM 2000 Control Delay	13.3	HCM 2000 Level of Service	B
HCM 2000 Volume to Capacity ratio	0.63		
Actuated Cycle Length (s)	73.6	Sum of lost time (s)	18.0
Intersection Capacity Utilization	57.8%	ICU Level of Service	B
Analysis Period (min)	15		

c Critical Lane Group

2029 No-Build Weekday Evening Peak Hour
1: King St/Chestnut St & Route 140

01/18/2022

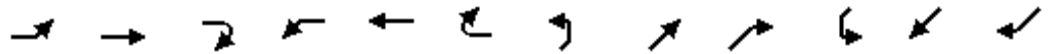

Lane Group	EBL	EBT	EBR	WBL	WBT	WBR	NEL	NET	NER	SWL	SWT	SWR
Lane Configurations												
Traffic Volume (vph)	163	468	45	399	484	54	33	302	336	33	336	129
Future Volume (vph)	163	468	45	399	484	54	33	302	336	33	336	129
Ideal Flow (vphpl)	1900	1900	1900	1900	1900	1900	1900	1900	1900	1900	1900	1900
Lane Width (ft)	12	11	11	11	11	11	11	11	11	16	16	16
Storage Length (ft)	100		50	165		50	0		80	0		0
Storage Lanes	1		0	1		0	0		1	0		0
Taper Length (ft)	25			25			25			25		
Right Turn on Red			Yes			Yes			Yes			Yes
Link Speed (mph)		30			30			30				30
Link Distance (ft)		639			1214			457				724
Travel Time (s)		14.5			27.6			10.4				16.5
Peak Hour Factor	0.93	0.93	0.93	0.93	0.93	0.93	0.91	0.91	0.91	0.81	0.81	0.81
Heavy Vehicles (%)	0%	0%	0%	0%	0%	0%	4%	1%	1%	0%	1%	0%
Shared Lane Traffic (%)												
Lane Group Flow (vph)	175	551	0	429	578	0	0	368	369	0	615	0
Turn Type	pm+pt	NA		pm+pt	NA		Perm	NA	pm+ov	Perm	NA	
Protected Phases	5	2		1	6			8	1			4
Permitted Phases	2			6			8		8	4		
Detector Phase	5	2		1	6		8	8	1	4		4
Switch Phase												
Minimum Initial (s)	6.0	6.0		6.0	6.0		6.0	6.0	6.0	6.0		6.0
Minimum Split (s)	11.0	21.0		11.0	21.0		21.0	21.0	11.0	21.0		21.0
Total Split (s)	20.0	40.0		20.0	40.0		35.0	35.0	20.0	35.0		35.0
Total Split (%)	17.1%	34.2%		17.1%	34.2%		29.9%	29.9%	17.1%	29.9%		29.9%
Yellow Time (s)	3.0	3.0		3.0	3.0		3.0	3.0	3.0	3.0		3.0
All-Red Time (s)	2.0	2.0		2.0	2.0		2.0	2.0	2.0	2.0		2.0
Lost Time Adjust (s)	-1.0	-1.0		-1.0	-1.0			-1.0	-1.0			-1.0
Total Lost Time (s)	4.0	4.0		4.0	4.0			4.0	4.0			4.0
Lead/Lag	Lead	Lag		Lead	Lag				Lead			
Lead-Lag Optimize?	Yes	Yes		Yes	Yes				Yes			
Recall Mode	None	None		None	None		None	None	None	None		None
v/c Ratio	0.52	0.84		1.16	0.78			0.83	0.40			1.23
Control Delay	18.0	42.5		124.2	35.7			49.6	7.4			151.7
Queue Delay	0.0	0.0		0.0	0.0			0.0	0.0			0.0
Total Delay	18.0	42.5		124.2	35.7			49.6	7.4			151.7
Queue Length 50th (ft)	44	289		~240	281			201	40			~448
Queue Length 95th (ft)	117	#633		#580	#679			#469	143			#729
Internal Link Dist (ft)		559			1134			377				644
Turn Bay Length (ft)	100			165					80			
Base Capacity (vph)	423	667		370	743			446	914			499
Starvation Cap Reductn	0	0		0	0			0	0			0
Spillback Cap Reductn	0	0		0	0			0	0			0
Storage Cap Reductn	0	0		0	0			0	0			0
Reduced v/c Ratio	0.41	0.83		1.16	0.78			0.83	0.40			1.23

Intersection Summary

Area Type: Other
Cycle Length: 117

2029 No-Build Weekday Evening Peak Hour
 1: King St/Chestnut St & Route 140

01/18/2022

Lane Group	Ø9
Lane Configurations	
Traffic Volume (vph)	
Future Volume (vph)	
Ideal Flow (vphpl)	
Lane Width (ft)	
Storage Length (ft)	
Storage Lanes	
Taper Length (ft)	
Right Turn on Red	
Link Speed (mph)	
Link Distance (ft)	
Travel Time (s)	
Peak Hour Factor	
Heavy Vehicles (%)	
Shared Lane Traffic (%)	
Lane Group Flow (vph)	
Turn Type	
Protected Phases	9
Permitted Phases	
Detector Phase	
Switch Phase	
Minimum Initial (s)	4.0
Minimum Split (s)	21.0
Total Split (s)	22.0
Total Split (%)	19%
Yellow Time (s)	3.0
All-Red Time (s)	2.0
Lost Time Adjust (s)	
Total Lost Time (s)	
Lead/Lag	
Lead-Lag Optimize?	
Recall Mode	None
v/c Ratio	
Control Delay	
Queue Delay	
Total Delay	
Queue Length 50th (ft)	
Queue Length 95th (ft)	
Internal Link Dist (ft)	
Turn Bay Length (ft)	
Base Capacity (vph)	
Starvation Cap Reductn	
Spillback Cap Reductn	
Storage Cap Reductn	
Reduced v/c Ratio	
Intersection Summary	

2029 No-Build Weekday Evening Peak Hour
 1: King St/Chestnut St & Route 140

01/18/2022

Actuated Cycle Length: 98.8

Natural Cycle: 150

Control Type: Actuated-Uncoordinated







~ Volume exceeds capacity, queue is theoretically infinite.

Queue shown is maximum after two cycles.

95th percentile volume exceeds capacity, queue may be longer.

Queue shown is maximum after two cycles.

Splits and Phases: 1: King St/Chestnut St & Route 140

 Ø4	 Ø1	 Ø2	 Ø9
35 s	20 s	40 s	22 s
 Ø8	 Ø5	 Ø6	
35 s	20 s	40 s	

2029 No-Build Weekday Evening Peak Hour
1: King St/Chestnut St & Route 140

01/18/2022

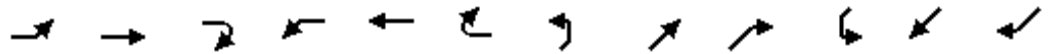

Movement	EBL	EBT	EBR	WBL	WBT	WBR	NEL	NET	NER	SWL	SWT	SWR
Lane Configurations												
Traffic Volume (vph)	163	468	45	399	484	54	33	302	336	33	336	129
Future Volume (vph)	163	468	45	399	484	54	33	302	336	33	336	129
Ideal Flow (vphpl)	1900	1900	1900	1900	1900	1900	1900	1900	1900	1900	1900	1900
Lane Width	12	11	11	11	11	11	11	11	11	16	16	16
Total Lost time (s)	4.0	4.0		4.0	4.0			4.0	4.0		4.0	
Lane Util. Factor	1.00	1.00		1.00	1.00			1.00	1.00		1.00	
Frt	1.00	0.99		1.00	0.98			1.00	0.85		0.97	
Flt Protected	0.95	1.00		0.95	1.00			1.00	1.00		1.00	
Satd. Flow (prot)	1805	1813		1745	1809			1804	1546		2057	
Flt Permitted	0.19	1.00		0.12	1.00			0.78	1.00		0.75	
Satd. Flow (perm)	356	1813		217	1809			1410	1546		1549	
Peak-hour factor, PHF	0.93	0.93	0.93	0.93	0.93	0.93	0.91	0.91	0.91	0.81	0.81	0.81
Adj. Flow (vph)	175	503	48	429	520	58	36	332	369	41	415	159
RTOR Reduction (vph)	0	3	0	0	3	0	0	0	124	0	10	0
Lane Group Flow (vph)	175	548	0	429	575	0	0	368	245	0	605	0
Heavy Vehicles (%)	0%	0%	0%	0%	0%	0%	4%	1%	1%	0%	1%	0%
Turn Type	pm+pt	NA		pm+pt	NA		Perm	NA	pm+ov	Perm	NA	
Protected Phases	5	2		1	6			8	1		4	
Permitted Phases	2			6			8		8	4		
Actuated Green, G (s)	45.2	34.8		54.6	39.5			30.2	45.3		30.2	
Effective Green, g (s)	47.2	35.8		55.9	40.5			31.2	47.3		31.2	
Actuated g/C Ratio	0.46	0.35		0.54	0.39			0.30	0.46		0.30	
Clearance Time (s)	5.0	5.0		5.0	5.0			5.0	5.0		5.0	
Vehicle Extension (s)	3.0	3.0		3.0	3.0			3.0	3.0		3.0	
Lane Grp Cap (vph)	324	631		357	712			427	771		470	
v/s Ratio Prot	0.06	0.30		c0.19	0.32				0.05			
v/s Ratio Perm	0.19			c0.47				0.26	0.11		c0.39	
v/c Ratio	0.54	0.87		1.20	0.81			0.86	0.32		1.29	
Uniform Delay, d1	19.3	31.3		29.2	27.7			33.8	17.5		35.8	
Progression Factor	1.00	1.00		1.00	1.00			1.00	1.00		1.00	
Incremental Delay, d2	1.8	12.2		114.6	6.7			16.2	0.2		144.2	
Delay (s)	21.1	43.5		143.8	34.4			50.0	17.8		180.0	
Level of Service	C	D		F	C			D	B		F	
Approach Delay (s)		38.1			81.0			33.8			180.0	
Approach LOS		D			F			C			F	

Intersection Summary

HCM 2000 Control Delay	79.4	HCM 2000 Level of Service	E
HCM 2000 Volume to Capacity ratio	1.23		
Actuated Cycle Length (s)	102.8	Sum of lost time (s)	17.0
Intersection Capacity Utilization	107.9%	ICU Level of Service	G
Analysis Period (min)	15		

c Critical Lane Group

2029 No-Build Weekday Evening Peak Hour
 2: CVS Dwy/Horace Mann Plaza Dwy & Route 140

01/18/2022



Lane Group	EBL	EBT	EBR	WBL	WBT	WBR	NBL	NBT	NBR	SBL	SBT	SBR
Lane Configurations												
Traffic Volume (vph)	206	623	50	21	753	147	36	19	35	135	17	220
Future Volume (vph)	206	623	50	21	753	147	36	19	35	135	17	220
Ideal Flow (vphpl)	1900	1900	1900	1900	1900	1900	1900	1900	1900	1900	1900	1900
Lane Width (ft)	10	11	11	11	11	11	11	11	11	13	13	12
Storage Length (ft)	160		50	100		150	0		26	50		0
Storage Lanes	1		1	1		1	0		1	0		1
Taper Length (ft)	25			25			25			25		
Right Turn on Red			Yes			Yes			Yes			Yes
Link Speed (mph)		30			30			30				30
Link Distance (ft)		1214			922			320				157
Travel Time (s)		27.6			21.0			7.3				3.6
Peak Hour Factor	0.94	0.94	0.94	0.91	0.91	0.91	0.95	0.95	0.95	0.96	0.96	0.96
Heavy Vehicles (%)	0%	1%	0%	0%	0%	0%	0%	0%	0%	0%	0%	0%
Shared Lane Traffic (%)												
Lane Group Flow (vph)	219	663	53	23	827	162	0	58	37	0	159	229
Turn Type	pm+pt	NA	custom	pm+pt	NA	custom	Perm	NA	Perm	Perm	NA	pm+ov
Protected Phases	5	2	2	1	6	6		8			4	5
Permitted Phases	2		2	6		6	8		8	4		4
Detector Phase	5	2	2	1	6	6	8	8	8	4	4	5
Switch Phase												
Minimum Initial (s)	5.0	10.0	10.0	5.0	10.0	10.0	5.0	5.0	5.0	5.0	5.0	5.0
Minimum Split (s)	10.0	15.0	15.0	10.0	15.0	15.0	9.0	9.0	9.0	9.0	9.0	10.0
Total Split (s)	20.0	44.0	44.0	20.0	44.0	44.0	24.0	24.0	24.0	24.0	24.0	20.0
Total Split (%)	18.2%	40.0%	40.0%	18.2%	40.0%	40.0%	21.8%	21.8%	21.8%	21.8%	21.8%	18.2%
Yellow Time (s)	4.0	4.0	4.0	4.0	4.0	4.0	3.0	3.0	3.0	3.0	3.0	4.0
All-Red Time (s)	1.0	1.0	1.0	1.0	1.0	1.0	1.0	1.0	1.0	1.0	1.0	1.0
Lost Time Adjust (s)	-1.0	-1.0	-1.0	-1.0	-1.0	-1.0		0.0	0.0		0.0	0.0
Total Lost Time (s)	4.0	4.0	4.0	4.0	4.0	4.0		4.0	4.0		4.0	5.0
Lead/Lag	Lead	Lag	Lag	Lead	Lag	Lag						Lead
Lead-Lag Optimize?												
Recall Mode	None	None	None	None	None	None	None	None	None	None	None	None
v/c Ratio	0.64	0.56	0.05	0.05	0.91	0.20		0.30	0.11		0.71	0.32
Control Delay	26.6	14.7	0.1	8.1	38.2	7.3		37.1	0.6		52.7	3.4
Queue Delay	0.0	0.0	0.0	0.0	0.0	0.0		0.0	0.0		0.0	0.0
Total Delay	26.6	14.7	0.1	8.1	38.2	7.3		37.1	0.6		52.7	3.4
Queue Length 50th (ft)	52	113	0	3	353	13		26	0		75	0
Queue Length 95th (ft)	#203	556	0	19	#951	70		75	0		176	34
Internal Link Dist (ft)		1134			842			240			77	
Turn Bay Length (ft)	160		50	100		150			26			
Base Capacity (vph)	407	1194	1062	657	909	827		299	475		344	765
Starvation Cap Reductn	0	0	0	0	0	0		0	0		0	0
Spillback Cap Reductn	0	0	0	0	0	0		0	0		0	0
Storage Cap Reductn	0	0	0	0	0	0		0	0		0	0
Reduced v/c Ratio	0.54	0.56	0.05	0.04	0.91	0.20		0.19	0.08		0.46	0.30

Intersection Summary

Area Type: Other
 Cycle Length: 110

Lane Group	Ø9
Lane Configurations	
Traffic Volume (vph)	
Future Volume (vph)	
Ideal Flow (vphpl)	
Lane Width (ft)	
Storage Length (ft)	
Storage Lanes	
Taper Length (ft)	
Right Turn on Red	
Link Speed (mph)	
Link Distance (ft)	
Travel Time (s)	
Peak Hour Factor	
Heavy Vehicles (%)	
Shared Lane Traffic (%)	
Lane Group Flow (vph)	
Turn Type	
Protected Phases	9
Permitted Phases	
Detector Phase	
Switch Phase	
Minimum Initial (s)	4.0
Minimum Split (s)	21.0
Total Split (s)	22.0
Total Split (%)	20%
Yellow Time (s)	3.0
All-Red Time (s)	2.0
Lost Time Adjust (s)	
Total Lost Time (s)	
Lead/Lag	
Lead-Lag Optimize?	
Recall Mode	None
v/c Ratio	
Control Delay	
Queue Delay	
Total Delay	
Queue Length 50th (ft)	
Queue Length 95th (ft)	
Internal Link Dist (ft)	
Turn Bay Length (ft)	
Base Capacity (vph)	
Starvation Cap Reductn	
Spillback Cap Reductn	
Storage Cap Reductn	
Reduced v/c Ratio	
Intersection Summary	

2029 No-Build Weekday Evening Peak Hour
 2: CVS Dwy/Horace Mann Plaza Dwy & Route 140

01/18/2022

Actuated Cycle Length: 82.9

Natural Cycle: 90

Control Type: Actuated-Uncoordinated

95th percentile volume exceeds capacity, queue may be longer.

Queue shown is maximum after two cycles.

Splits and Phases: 2: CVS Dwy/Horace Mann Plaza Dwy & Route 140

 Ø1	 Ø2	 Ø4	 Ø9
20 s	44 s	24 s	22 s
 Ø5	 Ø6	 Ø8	
20 s	44 s	24 s	

2029 No-Build Weekday Evening Peak Hour
 2: CVS Dwy/Horace Mann Plaza Dwy & Route 140

01/18/2022



Movement	EBL	EBT	EBR	WBL	WBT	WBR	NBL	NBT	NBR	SBL	SBT	SBR
Lane Configurations												
Traffic Volume (vph)	206	623	50	21	753	147	36	19	35	135	17	220
Future Volume (vph)	206	623	50	21	753	147	36	19	35	135	17	220
Ideal Flow (vphpl)	1900	1900	1900	1900	1900	1900	1900	1900	1900	1900	1900	1900
Lane Width	10	11	11	11	11	11	11	11	11	13	13	12
Total Lost time (s)	4.0	4.0	4.0	4.0	4.0	4.0		4.0	4.0		4.0	5.0
Lane Util. Factor	1.00	1.00	1.00	1.00	1.00	1.00		1.00	1.00		1.00	1.00
Frt	1.00	1.00	0.85	1.00	1.00	0.85		1.00	0.85		1.00	0.85
Flt Protected	0.95	1.00	1.00	0.95	1.00	1.00		0.97	1.00		0.96	1.00
Satd. Flow (prot)	1685	1818	1561	1745	1837	1561		1778	1561		1880	1615
Flt Permitted	0.08	1.00	1.00	0.35	1.00	1.00		0.66	1.00		0.71	1.00
Satd. Flow (perm)	147	1818	1561	644	1837	1561		1212	1561		1392	1615
Peak-hour factor, PHF	0.94	0.94	0.94	0.91	0.91	0.91	0.95	0.95	0.95	0.96	0.96	0.96
Adj. Flow (vph)	219	663	53	23	827	162	38	20	37	141	18	229
RTOR Reduction (vph)	0	0	21	0	0	55	0	0	32	0	0	165
Lane Group Flow (vph)	219	663	32	23	827	107	0	58	5	0	159	64
Heavy Vehicles (%)	0%	1%	0%	0%	0%	0%	0%	0%	0%	0%	0%	0%
Turn Type	pm+pt	NA	custom	pm+pt	NA	custom	Perm	NA	Perm	Perm	NA	pm+ov
Protected Phases	5	2	2	1	6	6		8			4	5
Permitted Phases	2		2	6		6	8		8	4		4
Actuated Green, G (s)	60.3	53.4	53.4	45.2	43.3	43.3		13.3	13.3		13.3	25.3
Effective Green, g (s)	61.3	54.4	54.4	47.2	44.3	44.3		13.3	13.3		13.3	25.3
Actuated g/C Ratio	0.68	0.60	0.60	0.52	0.49	0.49		0.15	0.15		0.15	0.28
Clearance Time (s)	5.0	5.0	5.0	5.0	5.0	5.0		4.0	4.0		4.0	5.0
Vehicle Extension (s)	2.0	2.0	2.0	2.0	2.0	2.0		2.0	2.0		2.0	2.0
Lane Grp Cap (vph)	322	1098	943	373	904	768		179	230		205	453
v/s Ratio Prot	c0.10	0.36	0.02	0.00	c0.45	0.07						0.02
v/s Ratio Perm	0.37			0.03				0.05	0.00		c0.11	0.02
v/c Ratio	0.68	0.60	0.03	0.06	0.91	0.14		0.32	0.02		0.78	0.14
Uniform Delay, d1	22.6	11.1	7.2	10.6	21.1	12.5		34.3	32.8		36.9	24.2
Progression Factor	1.00	1.00	1.00	1.00	1.00	1.00		1.00	1.00		1.00	1.00
Incremental Delay, d2	4.7	0.6	0.0	0.0	13.3	0.0		0.4	0.0		15.3	0.1
Delay (s)	27.2	11.7	7.2	10.6	34.4	12.5		34.7	32.8		52.2	24.3
Level of Service	C	B	A	B	C	B		C	C		D	C
Approach Delay (s)		15.1			30.4			34.0			35.7	
Approach LOS		B			C			C			D	

Intersection Summary

HCM 2000 Control Delay	25.5	HCM 2000 Level of Service	C
HCM 2000 Volume to Capacity ratio	0.83		
Actuated Cycle Length (s)	90.0	Sum of lost time (s)	18.0
Intersection Capacity Utilization	76.1%	ICU Level of Service	D
Analysis Period (min)	15		

c Critical Lane Group

2029 Build



2029 Build Weekday Morning Peak Hour
1: King St/Chestnut St & Route 140

01/18/2022

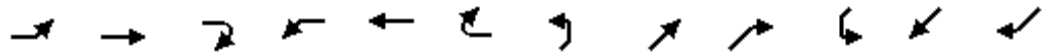

Lane Group	EBL	EBT	EBR	WBL	WBT	WBR	NEL	NET	NER	SWL	SWT	SWR
Lane Configurations												
Traffic Volume (vph)	84	375	35	249	316	63	28	367	344	24	271	106
Future Volume (vph)	84	375	35	249	316	63	28	367	344	24	271	106
Ideal Flow (vphpl)	1900	1900	1900	1900	1900	1900	1900	1900	1900	1900	1900	1900
Lane Width (ft)	12	11	11	11	11	11	11	11	11	16	16	16
Storage Length (ft)	100		50	165		50	0		80	0		0
Storage Lanes	1		0	1		0	0		1	0		0
Taper Length (ft)	25			25			25			25		
Right Turn on Red			Yes			Yes			Yes			Yes
Link Speed (mph)		30			30			30				30
Link Distance (ft)		639			741			457				724
Travel Time (s)		14.5			16.8			10.4				16.5
Peak Hour Factor	0.92	0.92	0.92	0.99	0.99	0.99	0.89	0.89	0.89	0.90	0.90	0.90
Heavy Vehicles (%)	6%	2%	0%	1%	2%	0%	0%	2%	1%	11%	2%	3%
Shared Lane Traffic (%)												
Lane Group Flow (vph)	91	446	0	252	383	0	0	443	387	0	446	0
Turn Type	pm+pt	NA		pm+pt	NA		Perm	NA	pm+ov	Perm	NA	
Protected Phases	5	2		1	6			8	1			4
Permitted Phases	2			6			8		8	4		
Detector Phase	5	2		1	6		8	8	1	4		4
Switch Phase												
Minimum Initial (s)	6.0	6.0		6.0	6.0		6.0	6.0	6.0	6.0		6.0
Minimum Split (s)	11.0	21.0		11.0	21.0		21.0	21.0	11.0	21.0		21.0
Total Split (s)	20.0	40.0		20.0	40.0		35.0	35.0	20.0	35.0		35.0
Total Split (%)	17.1%	34.2%		17.1%	34.2%		29.9%	29.9%	17.1%	29.9%		29.9%
Yellow Time (s)	3.0	3.0		3.0	3.0		3.0	3.0	3.0	3.0		3.0
All-Red Time (s)	2.0	2.0		2.0	2.0		2.0	2.0	2.0	2.0		2.0
Lost Time Adjust (s)	-1.0	-1.0		-1.0	-1.0			-1.0	-1.0			-1.0
Total Lost Time (s)	4.0	4.0		4.0	4.0			4.0	4.0			4.0
Lead/Lag	Lead	Lag		Lead	Lag				Lead			
Lead-Lag Optimize?	Yes	Yes		Yes	Yes				Yes			
Recall Mode	None	None		None	None		None	None	None	None		None
v/c Ratio	0.22	0.80		0.66	0.55			0.73	0.41			0.75
Control Delay	13.8	40.3		23.0	26.2			36.7	8.3			36.7
Queue Delay	0.0	0.0		0.0	0.0			0.0	0.0			0.0
Total Delay	13.8	40.3		23.0	26.2			36.7	8.3			36.7
Queue Length 50th (ft)	22	207		68	153			199	45			196
Queue Length 95th (ft)	66	#463		#194	342			#528	173			#541
Internal Link Dist (ft)		559			661			377				644
Turn Bay Length (ft)	100			165					80			
Base Capacity (vph)	548	741		426	761			606	991			597
Starvation Cap Reductn	0	0		0	0			0	0			0
Spillback Cap Reductn	0	0		0	0			0	0			0
Storage Cap Reductn	0	0		0	0			0	0			0
Reduced v/c Ratio	0.17	0.60		0.59	0.50			0.73	0.39			0.75

Intersection Summary

Area Type: Other
Cycle Length: 117

Lane Group	Ø9
Lane Configurations	
Traffic Volume (vph)	
Future Volume (vph)	
Ideal Flow (vphpl)	
Lane Width (ft)	
Storage Length (ft)	
Storage Lanes	
Taper Length (ft)	
Right Turn on Red	
Link Speed (mph)	
Link Distance (ft)	
Travel Time (s)	
Peak Hour Factor	
Heavy Vehicles (%)	
Shared Lane Traffic (%)	
Lane Group Flow (vph)	
Turn Type	
Protected Phases	9
Permitted Phases	
Detector Phase	
Switch Phase	
Minimum Initial (s)	4.0
Minimum Split (s)	21.0
Total Split (s)	22.0
Total Split (%)	19%
Yellow Time (s)	3.0
All-Red Time (s)	2.0
Lost Time Adjust (s)	
Total Lost Time (s)	
Lead/Lag	
Lead-Lag Optimize?	
Recall Mode	None
v/c Ratio	
Control Delay	
Queue Delay	
Total Delay	
Queue Length 50th (ft)	
Queue Length 95th (ft)	
Internal Link Dist (ft)	
Turn Bay Length (ft)	
Base Capacity (vph)	
Starvation Cap Reductn	
Spillback Cap Reductn	
Storage Cap Reductn	
Reduced v/c Ratio	
Intersection Summary	

2029 Build Weekday Morning Peak Hour
 1: King St/Chestnut St & Route 140

01/18/2022

Actuated Cycle Length: 88.9







Natural Cycle: 90

Control Type: Actuated-Uncoordinated

95th percentile volume exceeds capacity, queue may be longer.

Queue shown is maximum after two cycles.

Splits and Phases: 1: King St/Chestnut St & Route 140

 Ø4	 Ø1	 Ø2	 Ø9
35 s	20 s	40 s	22 s
 Ø8	 Ø5	 Ø6	
35 s	20 s	40 s	

2029 Build Weekday Morning Peak Hour
1: King St/Chestnut St & Route 140

01/18/2022



Movement	EBL	EBT	EBR	WBL	WBT	WBR	NEL	NET	NER	SWL	SWT	SWR
Lane Configurations												
Traffic Volume (vph)	84	375	35	249	316	63	28	367	344	24	271	106
Future Volume (vph)	84	375	35	249	316	63	28	367	344	24	271	106
Ideal Flow (vphpl)	1900	1900	1900	1900	1900	1900	1900	1900	1900	1900	1900	1900
Lane Width	12	11	11	11	11	11	11	11	11	16	16	16
Total Lost time (s)	4.0	4.0		4.0	4.0			4.0	4.0		4.0	
Lane Util. Factor	1.00	1.00		1.00	1.00			1.00	1.00		1.00	
Frt	1.00	0.99		1.00	0.97			1.00	0.85		0.96	
Flt Protected	0.95	1.00		0.95	1.00			1.00	1.00		1.00	
Satd. Flow (prot)	1703	1781		1728	1761			1797	1546		2014	
Flt Permitted	0.42	1.00		0.18	1.00			0.94	1.00		0.81	
Satd. Flow (perm)	756	1781		327	1761			1696	1546		1643	
Peak-hour factor, PHF	0.92	0.92	0.92	0.99	0.99	0.99	0.89	0.89	0.89	0.90	0.90	0.90
Adj. Flow (vph)	91	408	38	252	319	64	31	412	387	27	301	118
RTOR Reduction (vph)	0	3	0	0	6	0	0	0	104	0	10	0
Lane Group Flow (vph)	91	443	0	252	377	0	0	443	283	0	436	0
Heavy Vehicles (%)	6%	2%	0%	1%	2%	0%	0%	2%	1%	11%	2%	3%
Turn Type	pm+pt	NA		pm+pt	NA		Perm	NA	pm+ov	Perm	NA	
Protected Phases	5	2		1	6			8	1		4	
Permitted Phases	2			6			8		8	4		
Actuated Green, G (s)	35.0	28.2		45.8	34.0			30.8	43.4		30.8	
Effective Green, g (s)	37.0	29.2		46.8	35.0			31.8	45.4		31.8	
Actuated g/C Ratio	0.39	0.31		0.50	0.37			0.34	0.48		0.34	
Clearance Time (s)	5.0	5.0		5.0	5.0			5.0	5.0		5.0	
Vehicle Extension (s)	3.0	3.0		3.0	3.0			3.0	3.0		3.0	
Lane Grp Cap (vph)	375	552		365	654			573	811		555	
v/s Ratio Prot	0.02	c0.25		c0.10	0.21				0.05			
v/s Ratio Perm	0.08			0.24				0.26	0.13		c0.27	
v/c Ratio	0.24	0.80		0.69	0.58			0.77	0.35		0.79	
Uniform Delay, d1	18.5	29.8		17.3	23.6			27.9	15.2		28.1	
Progression Factor	1.00	1.00		1.00	1.00			1.00	1.00		1.00	
Incremental Delay, d2	0.3	8.3		5.5	1.2			6.4	0.3		7.2	
Delay (s)	18.9	38.1		22.8	24.9			34.3	15.4		35.3	
Level of Service	B	D		C	C			C	B		D	
Approach Delay (s)		34.8			24.1			25.5			35.3	
Approach LOS		C			C			C			D	

Intersection Summary

HCM 2000 Control Delay	29.0	HCM 2000 Level of Service	C
HCM 2000 Volume to Capacity ratio	0.75		
Actuated Cycle Length (s)	94.1	Sum of lost time (s)	17.0
Intersection Capacity Utilization	86.8%	ICU Level of Service	E
Analysis Period (min)	15		

c Critical Lane Group

2029 Build Weekday Morning Peak Hour
 2: CVS Dwy/Horace Mann Plaza Dwy & Route 140

01/18/2022



Lane Group	EBL	EBT	EBR	WBL	WBT	WBR	NBL	NBT	NBR	SBL	SBT	SBR
Lane Configurations												
Traffic Volume (vph)	98	629	20	8	523	59	20	4	13	76	5	65
Future Volume (vph)	98	629	20	8	523	59	20	4	13	76	5	65
Ideal Flow (vphpl)	1900	1900	1900	1900	1900	1900	1900	1900	1900	1900	1900	1900
Lane Width (ft)	10	11	11	11	11	11	11	11	11	13	13	12
Storage Length (ft)	160		50	100		150	0		26	50		0
Storage Lanes	1		1	1		1	0		1	0		1
Taper Length (ft)	25			25			25			25		
Right Turn on Red			Yes			Yes			Yes			Yes
Link Speed (mph)		30			30			30				30
Link Distance (ft)		473			741			320				157
Travel Time (s)		10.8			16.8			7.3				3.6
Peak Hour Factor	0.87	0.87	0.87	0.85	0.85	0.85	0.82	0.82	0.82	0.85	0.85	0.85
Heavy Vehicles (%)	0%	2%	0%	0%	0%	0%	0%	0%	0%	0%	0%	0%
Shared Lane Traffic (%)												
Lane Group Flow (vph)	113	723	23	9	615	69	0	29	16	0	95	76
Turn Type	pm+pt	NA	custom	pm+pt	NA	custom	Perm	NA	Perm	Perm	NA	pm+ov
Protected Phases	5	2	2	1	6	6		8			4	5
Permitted Phases	2		2	6		6	8		8	4		4
Detector Phase	5	2	2	1	6	6	8	8	8	4	4	5
Switch Phase												
Minimum Initial (s)	5.0	10.0	10.0	5.0	10.0	10.0	5.0	5.0	5.0	5.0	5.0	5.0
Minimum Split (s)	10.0	15.0	15.0	10.0	15.0	15.0	9.0	9.0	9.0	9.0	9.0	10.0
Total Split (s)	20.0	44.0	44.0	20.0	44.0	44.0	24.0	24.0	24.0	24.0	24.0	20.0
Total Split (%)	18.2%	40.0%	40.0%	18.2%	40.0%	40.0%	21.8%	21.8%	21.8%	21.8%	21.8%	18.2%
Yellow Time (s)	4.0	4.0	4.0	4.0	4.0	4.0	3.0	3.0	3.0	3.0	3.0	4.0
All-Red Time (s)	1.0	1.0	1.0	1.0	1.0	1.0	1.0	1.0	1.0	1.0	1.0	1.0
Lost Time Adjust (s)	-1.0	-1.0	-1.0	-1.0	-1.0	-1.0		0.0	0.0		0.0	0.0
Total Lost Time (s)	4.0	4.0	4.0	4.0	4.0	4.0		4.0	4.0		4.0	5.0
Lead/Lag	Lead	Lag	Lag	Lead	Lag	Lag						Lead
Lead-Lag Optimize?												
Recall Mode	None	None	None	None	None	None	None	None	None	None	None	None
v/c Ratio	0.23	0.56	0.02	0.02	0.57	0.07		0.15	0.05		0.46	0.15
Control Delay	7.0	12.7	0.1	7.1	18.3	1.5		31.1	0.3		37.2	4.8
Queue Delay	0.0	0.0	0.0	0.0	0.0	0.0		0.0	0.0		0.0	0.0
Total Delay	7.0	12.7	0.1	7.1	18.3	1.5		31.1	0.3		37.2	4.8
Queue Length 50th (ft)	9	93	0	1	148	0		9	0		30	0
Queue Length 95th (ft)	58	#611	0	9	#476	7		39	0		101	19
Internal Link Dist (ft)		393			661			240			77	
Turn Bay Length (ft)	160		50	100		150			26			
Base Capacity (vph)	656	1294	1152	709	1255	1101		440	598		469	708
Starvation Cap Reductn	0	0	0	0	0	0		0	0		0	0
Spillback Cap Reductn	0	0	0	0	0	0		0	0		0	0
Storage Cap Reductn	0	0	0	0	0	0		0	0		0	0
Reduced v/c Ratio	0.17	0.56	0.02	0.01	0.49	0.06		0.07	0.03		0.20	0.11

Intersection Summary

Area Type: Other
 Cycle Length: 110

Lane Group	Ø9
Lane Configurations	
Traffic Volume (vph)	
Future Volume (vph)	
Ideal Flow (vphpl)	
Lane Width (ft)	
Storage Length (ft)	
Storage Lanes	
Taper Length (ft)	
Right Turn on Red	
Link Speed (mph)	
Link Distance (ft)	
Travel Time (s)	
Peak Hour Factor	
Heavy Vehicles (%)	
Shared Lane Traffic (%)	
Lane Group Flow (vph)	
Turn Type	
Protected Phases	9
Permitted Phases	
Detector Phase	
Switch Phase	
Minimum Initial (s)	4.0
Minimum Split (s)	21.0
Total Split (s)	22.0
Total Split (%)	20%
Yellow Time (s)	3.0
All-Red Time (s)	2.0
Lost Time Adjust (s)	
Total Lost Time (s)	
Lead/Lag	
Lead-Lag Optimize?	
Recall Mode	None
v/c Ratio	
Control Delay	
Queue Delay	
Total Delay	
Queue Length 50th (ft)	
Queue Length 95th (ft)	
Internal Link Dist (ft)	
Turn Bay Length (ft)	
Base Capacity (vph)	
Starvation Cap Reductn	
Spillback Cap Reductn	
Storage Cap Reductn	
Reduced v/c Ratio	
Intersection Summary	

2029 Build Weekday Morning Peak Hour
 2: CVS Dwy/Horace Mann Plaza Dwy & Route 140

01/18/2022

Actuated Cycle Length: 64.9

Natural Cycle: 80

Control Type: Actuated-Uncoordinated

95th percentile volume exceeds capacity, queue may be longer.

Queue shown is maximum after two cycles.

Splits and Phases: 2: CVS Dwy/Horace Mann Plaza Dwy & Route 140

 01 20 s	 02 44 s	 04 24 s	 09 22 s
 05 20 s	 06 44 s	 08 24 s	

2029 Build Weekday Morning Peak Hour
2: CVS Dwy/Horace Mann Plaza Dwy & Route 140

01/18/2022



Movement	EBL	EBT	EBR	WBL	WBT	WBR	NBL	NBT	NBR	SBL	SBT	SBR
Lane Configurations												
Traffic Volume (vph)	98	629	20	8	523	59	20	4	13	76	5	65
Future Volume (vph)	98	629	20	8	523	59	20	4	13	76	5	65
Ideal Flow (vphpl)	1900	1900	1900	1900	1900	1900	1900	1900	1900	1900	1900	1900
Lane Width	10	11	11	11	11	11	11	11	11	13	13	12
Total Lost time (s)	4.0	4.0	4.0	4.0	4.0	4.0		4.0	4.0		4.0	5.0
Lane Util. Factor	1.00	1.00	1.00	1.00	1.00	1.00		1.00	1.00		1.00	1.00
Frt	1.00	1.00	0.85	1.00	1.00	0.85		1.00	0.85		1.00	0.85
Flt Protected	0.95	1.00	1.00	0.95	1.00	1.00		0.96	1.00		0.96	1.00
Satd. Flow (prot)	1685	1801	1561	1745	1837	1561		1764	1561		1875	1615
Flt Permitted	0.26	1.00	1.00	0.29	1.00	1.00		0.72	1.00		0.72	1.00
Satd. Flow (perm)	458	1801	1561	540	1837	1561		1325	1561		1410	1615
Peak-hour factor, PHF	0.87	0.87	0.87	0.85	0.85	0.85	0.82	0.82	0.82	0.85	0.85	0.85
Adj. Flow (vph)	113	723	23	9	615	69	24	5	16	89	6	76
RTOR Reduction (vph)	0	0	9	0	0	32	0	0	14	0	0	62
Lane Group Flow (vph)	113	723	14	9	615	37	0	29	2	0	95	14
Heavy Vehicles (%)	0%	2%	0%	0%	0%	0%	0%	0%	0%	0%	0%	0%
Turn Type	pm+pt	NA	custom	pm+pt	NA	custom	Perm	NA	Perm	Perm	NA	pm+ov
Protected Phases	5	2	2	1	6	6		8			4	5
Permitted Phases	2		2	6		6	8		8	4		4
Actuated Green, G (s)	50.1	44.4	44.4	39.7	39.0	39.0		8.0	8.0		8.0	14.1
Effective Green, g (s)	51.1	45.4	45.4	41.7	40.0	40.0		8.0	8.0		8.0	14.1
Actuated g/C Ratio	0.69	0.61	0.61	0.56	0.54	0.54		0.11	0.11		0.11	0.19
Clearance Time (s)	5.0	5.0	5.0	5.0	5.0	5.0		4.0	4.0		4.0	5.0
Vehicle Extension (s)	2.0	2.0	2.0	2.0	2.0	2.0		2.0	2.0		2.0	2.0
Lane Grp Cap (vph)	433	1103	956	331	991	842		143	168		152	307
v/s Ratio Prot	c0.02	c0.40	0.01	0.00	0.33	0.02						0.00
v/s Ratio Perm	0.15			0.01				0.02	0.00		c0.07	0.01
v/c Ratio	0.26	0.66	0.01	0.03	0.62	0.04		0.20	0.01		0.62	0.05
Uniform Delay, d1	6.3	9.3	5.6	7.8	11.8	8.0		30.1	29.5		31.6	24.5
Progression Factor	1.00	1.00	1.00	1.00	1.00	1.00		1.00	1.00		1.00	1.00
Incremental Delay, d2	0.1	1.1	0.0	0.0	0.9	0.0		0.3	0.0		5.7	0.0
Delay (s)	6.4	10.4	5.6	7.8	12.7	8.0		30.4	29.5		37.3	24.5
Level of Service	A	B	A	A	B	A		C	C		D	C
Approach Delay (s)		9.7			12.1			30.1			31.6	
Approach LOS		A			B			C			C	

Intersection Summary

HCM 2000 Control Delay	13.3	HCM 2000 Level of Service	B
HCM 2000 Volume to Capacity ratio	0.63		
Actuated Cycle Length (s)	74.1	Sum of lost time (s)	18.0
Intersection Capacity Utilization	58.4%	ICU Level of Service	B
Analysis Period (min)	15		

c Critical Lane Group

2029 Build Weekday Morning Peak Hour
 3: Site Driveway & Route 140

01/18/2022



Lane Group	EBT	EBR	WBL	WBT	NBL	NBR
Lane Configurations						
Traffic Volume (vph)	738	5	4	612	16	11
Future Volume (vph)	738	5	4	612	16	11
Ideal Flow (vphpl)	1900	1900	1900	1900	1900	1900
Lane Width (ft)	16	12	12	16	12	12
Link Speed (mph)	30			30	30	
Link Distance (ft)	741			473	270	
Travel Time (s)	16.8			10.8	6.1	
Peak Hour Factor	0.92	0.92	0.92	0.92	0.92	0.92
Shared Lane Traffic (%)						
Lane Group Flow (vph)	807	0	0	669	29	0
Sign Control	Free			Free	Stop	

Intersection Summary

Area Type: Other

Control Type: Unsignalized

2029 Build Weekday Morning Peak Hour
3: Site Driveway & Route 140

01/18/2022

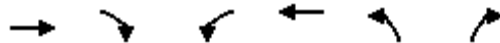

Movement	EBT	EBR	WBL	WBT	NBL	NBR
Lane Configurations	↔			↔	↔	
Traffic Volume (veh/h)	738	5	4	612	16	11
Future Volume (Veh/h)	738	5	4	612	16	11
Sign Control	Free			Free	Stop	
Grade	0%			0%	0%	
Peak Hour Factor	0.92	0.92	0.92	0.92	0.92	0.92
Hourly flow rate (vph)	802	5	4	665	17	12
Pedestrians						
Lane Width (ft)						
Walking Speed (ft/s)						
Percent Blockage						
Right turn flare (veh)						
Median type	None			None		
Median storage (veh)						
Upstream signal (ft)	741			473		
pX, platoon unblocked			0.79		0.87	0.79
vC, conflicting volume			807		1478	804
vC1, stage 1 conf vol						
vC2, stage 2 conf vol						
vCu, unblocked vol			619		923	616
tC, single (s)			4.1		6.4	6.2
tC, 2 stage (s)						
tF (s)			2.2		3.5	3.3
p0 queue free %			99		93	97
cM capacity (veh/h)			756		259	386
Direction, Lane #	EB 1	WB 1	NB 1			
Volume Total	807	669	29			
Volume Left	0	4	17			
Volume Right	5	0	12			
cSH	1700	756	300			
Volume to Capacity	0.47	0.01	0.10			
Queue Length 95th (ft)	0	0	8			
Control Delay (s)	0.0	0.1	18.3			
Lane LOS		A	C			
Approach Delay (s)	0.0	0.1	18.3			
Approach LOS			C			
Intersection Summary						
Average Delay			0.4			
Intersection Capacity Utilization			49.1%	ICU Level of Service		A
Analysis Period (min)			15			

2029 Build Weekday Evening Peak Hour
1: King St/Chestnut St & Route 140

01/18/2022

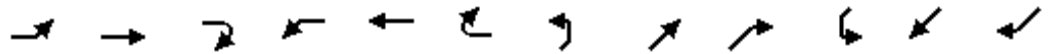

Lane Group	EBL	EBT	EBR	WBL	WBT	WBR	NEL	NET	NER	SWL	SWT	SWR
Lane Configurations												
Traffic Volume (vph)	163	475	45	403	488	55	33	302	342	34	336	129
Future Volume (vph)	163	475	45	403	488	55	33	302	342	34	336	129
Ideal Flow (vphpl)	1900	1900	1900	1900	1900	1900	1900	1900	1900	1900	1900	1900
Lane Width (ft)	12	11	11	11	11	11	11	11	11	16	16	16
Storage Length (ft)	100		50	165		50	0		80	0		0
Storage Lanes	1		0	1		0	0		1	0		0
Taper Length (ft)	25			25			25			25		
Right Turn on Red			Yes			Yes			Yes			Yes
Link Speed (mph)		30			30			30				30
Link Distance (ft)		639			751			457				724
Travel Time (s)		14.5			17.1			10.4				16.5
Peak Hour Factor	0.93	0.93	0.93	0.93	0.93	0.93	0.91	0.91	0.91	0.81	0.81	0.81
Heavy Vehicles (%)	0%	0%	0%	0%	0%	0%	4%	1%	1%	0%	1%	0%
Shared Lane Traffic (%)												
Lane Group Flow (vph)	175	559	0	433	584	0	0	368	376	0	616	0
Turn Type	pm+pt	NA		pm+pt	NA		Perm	NA	pm+ov	Perm	NA	
Protected Phases	5	2		1	6			8	1			4
Permitted Phases	2			6			8		8	4		
Detector Phase	5	2		1	6		8	8	1	4		4
Switch Phase												
Minimum Initial (s)	6.0	6.0		6.0	6.0		6.0	6.0	6.0	6.0		6.0
Minimum Split (s)	11.0	21.0		11.0	21.0		21.0	21.0	11.0	21.0		21.0
Total Split (s)	20.0	40.0		20.0	40.0		35.0	35.0	20.0	35.0		35.0
Total Split (%)	17.1%	34.2%		17.1%	34.2%		29.9%	29.9%	17.1%	29.9%		29.9%
Yellow Time (s)	3.0	3.0		3.0	3.0		3.0	3.0	3.0	3.0		3.0
All-Red Time (s)	2.0	2.0		2.0	2.0		2.0	2.0	2.0	2.0		2.0
Lost Time Adjust (s)	-1.0	-1.0		-1.0	-1.0				-1.0	-1.0		-1.0
Total Lost Time (s)	4.0	4.0		4.0	4.0				4.0	4.0		4.0
Lead/Lag	Lead	Lag		Lead	Lag				Lead			
Lead-Lag Optimize?	Yes	Yes		Yes	Yes				Yes			
Recall Mode	None	None		None	None		None	None	None	None		None
v/c Ratio	0.52	0.84		1.19	0.78			0.83	0.41			1.25
Control Delay	18.1	42.9		134.3	35.8			50.3	7.5			161.2
Queue Delay	0.0	0.0		0.0	0.0			0.0	0.0			0.0
Total Delay	18.1	42.9		134.3	35.8			50.3	7.5			161.2
Queue Length 50th (ft)	44	296		~250	285			201	41			~453
Queue Length 95th (ft)	117	#648		#592	#690			#470	146			#735
Internal Link Dist (ft)		559			671			377				644
Turn Bay Length (ft)	100			165					80			
Base Capacity (vph)	420	664		365	748			442	912			491
Starvation Cap Reductn	0	0		0	0			0	0			0
Spillback Cap Reductn	0	0		0	0			0	0			0
Storage Cap Reductn	0	0		0	0			0	0			0
Reduced v/c Ratio	0.42	0.84		1.19	0.78			0.83	0.41			1.25

Intersection Summary

Area Type: Other
Cycle Length: 117

2029 Build Weekday Evening Peak Hour
 1: King St/Chestnut St & Route 140

01/18/2022

Lane Group	Ø9
Lane Configurations	
Traffic Volume (vph)	
Future Volume (vph)	
Ideal Flow (vphpl)	
Lane Width (ft)	
Storage Length (ft)	
Storage Lanes	
Taper Length (ft)	
Right Turn on Red	
Link Speed (mph)	
Link Distance (ft)	
Travel Time (s)	
Peak Hour Factor	
Heavy Vehicles (%)	
Shared Lane Traffic (%)	
Lane Group Flow (vph)	
Turn Type	
Protected Phases	9
Permitted Phases	
Detector Phase	
Switch Phase	
Minimum Initial (s)	4.0
Minimum Split (s)	21.0
Total Split (s)	22.0
Total Split (%)	19%
Yellow Time (s)	3.0
All-Red Time (s)	2.0
Lost Time Adjust (s)	
Total Lost Time (s)	
Lead/Lag	
Lead-Lag Optimize?	
Recall Mode	None
v/c Ratio	
Control Delay	
Queue Delay	
Total Delay	
Queue Length 50th (ft)	
Queue Length 95th (ft)	
Internal Link Dist (ft)	
Turn Bay Length (ft)	
Base Capacity (vph)	
Starvation Cap Reductn	
Spillback Cap Reductn	
Storage Cap Reductn	
Reduced v/c Ratio	
Intersection Summary	

2029 Build Weekday Evening Peak Hour
 1: King St/Chestnut St & Route 140

01/18/2022

Actuated Cycle Length: 99.2

Natural Cycle: 150

Control Type: Actuated-Uncoordinated







~ Volume exceeds capacity, queue is theoretically infinite.

Queue shown is maximum after two cycles.

95th percentile volume exceeds capacity, queue may be longer.

Queue shown is maximum after two cycles.

Splits and Phases: 1: King St/Chestnut St & Route 140

 Ø4	 Ø1	 Ø2	 Ø9
35 s	20 s	40 s	22 s
 Ø8	 Ø5	 Ø6	
35 s	20 s	40 s	

2029 Build Weekday Evening Peak Hour
1: King St/Chestnut St & Route 140

01/18/2022

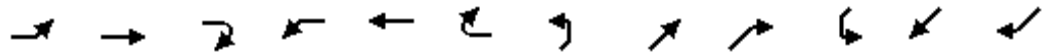

Movement	EBL	EBT	EBR	WBL	WBT	WBR	NEL	NET	NER	SWL	SWT	SWR
Lane Configurations												
Traffic Volume (vph)	163	475	45	403	488	55	33	302	342	34	336	129
Future Volume (vph)	163	475	45	403	488	55	33	302	342	34	336	129
Ideal Flow (vphpl)	1900	1900	1900	1900	1900	1900	1900	1900	1900	1900	1900	1900
Lane Width	12	11	11	11	11	11	11	11	11	16	16	16
Total Lost time (s)	4.0	4.0		4.0	4.0			4.0	4.0		4.0	
Lane Util. Factor	1.00	1.00		1.00	1.00			1.00	1.00		1.00	
Frt	1.00	0.99		1.00	0.98			1.00	0.85		0.97	
Flt Protected	0.95	1.00		0.95	1.00			1.00	1.00		1.00	
Satd. Flow (prot)	1805	1813		1745	1809			1804	1546		2057	
Flt Permitted	0.18	1.00		0.11	1.00			0.78	1.00		0.74	
Satd. Flow (perm)	349	1813		208	1809			1406	1546		1529	
Peak-hour factor, PHF	0.93	0.93	0.93	0.93	0.93	0.93	0.91	0.91	0.91	0.81	0.81	0.81
Adj. Flow (vph)	175	511	48	433	525	59	36	332	376	42	415	159
RTOR Reduction (vph)	0	3	0	0	3	0	0	0	127	0	10	0
Lane Group Flow (vph)	175	556	0	433	581	0	0	368	249	0	606	0
Heavy Vehicles (%)	0%	0%	0%	0%	0%	0%	4%	1%	1%	0%	1%	0%
Turn Type	pm+pt	NA		pm+pt	NA		Perm	NA	pm+ov	Perm	NA	
Protected Phases	5	2		1	6			8	1		4	
Permitted Phases	2			6			8		8	4		
Actuated Green, G (s)	45.6	35.2		55.0	39.9			30.2	45.3		30.2	
Effective Green, g (s)	47.6	36.2		56.3	40.9			31.2	47.3		31.2	
Actuated g/C Ratio	0.46	0.35		0.55	0.40			0.30	0.46		0.30	
Clearance Time (s)	5.0	5.0		5.0	5.0			5.0	5.0		5.0	
Vehicle Extension (s)	3.0	3.0		3.0	3.0			3.0	3.0		3.0	
Lane Grp Cap (vph)	321	635		353	716			425	768		462	
v/s Ratio Prot	0.06	0.31		c0.19	0.32				0.05			
v/s Ratio Perm	0.19			c0.48				0.26	0.11		c0.40	
v/c Ratio	0.55	0.88		1.23	0.81			0.87	0.32		1.31	
Uniform Delay, d1	19.3	31.4		29.8	27.7			34.0	17.8		36.0	
Progression Factor	1.00	1.00		1.00	1.00			1.00	1.00		1.00	
Incremental Delay, d2	1.9	12.9		124.6	7.0			16.6	0.2		154.7	
Delay (s)	21.2	44.3		154.3	34.7			50.7	18.0		190.7	
Level of Service	C	D		F	C			D	B		F	
Approach Delay (s)		38.8			85.6			34.2			190.7	
Approach LOS		D			F			C			F	

Intersection Summary

HCM 2000 Control Delay	83.1	HCM 2000 Level of Service	F
HCM 2000 Volume to Capacity ratio	1.26		
Actuated Cycle Length (s)	103.2	Sum of lost time (s)	17.0
Intersection Capacity Utilization	108.5%	ICU Level of Service	G
Analysis Period (min)	15		

c Critical Lane Group

2029 Build Weekday Evening Peak Hour
 2: CVS Dwy/Horace Mann Plaza Dwy & Route 140

01/18/2022



Lane Group	EBL	EBT	EBR	WBL	WBT	WBR	NBL	NBT	NBR	SBL	SBT	SBR
Lane Configurations												
Traffic Volume (vph)	206	629	50	21	762	147	36	19	35	135	17	220
Future Volume (vph)	206	629	50	21	762	147	36	19	35	135	17	220
Ideal Flow (vphpl)	1900	1900	1900	1900	1900	1900	1900	1900	1900	1900	1900	1900
Lane Width (ft)	10	11	11	11	11	11	11	11	11	13	13	12
Storage Length (ft)	160		50	100		150	0		26	50		0
Storage Lanes	1		1	1		1	0		1	0		1
Taper Length (ft)	25			25			25			25		
Right Turn on Red			Yes			Yes			Yes			Yes
Link Speed (mph)		30			30			30				30
Link Distance (ft)		463			922			320				157
Travel Time (s)		10.5			21.0			7.3				3.6
Peak Hour Factor	0.94	0.94	0.94	0.91	0.91	0.91	0.95	0.95	0.95	0.96	0.96	0.96
Heavy Vehicles (%)	0%	1%	0%	0%	0%	0%	0%	0%	0%	0%	0%	0%
Shared Lane Traffic (%)												
Lane Group Flow (vph)	219	669	53	23	837	162	0	58	37	0	159	229
Turn Type	pm+pt	NA	custom	pm+pt	NA	custom	Perm	NA	Perm	Perm	NA	pm+ov
Protected Phases	5	2	2	1	6	6		8			4	5
Permitted Phases	2		2	6		6	8		8	4		4
Detector Phase	5	2	2	1	6	6	8	8	8	4	4	5
Switch Phase												
Minimum Initial (s)	5.0	10.0	10.0	5.0	10.0	10.0	5.0	5.0	5.0	5.0	5.0	5.0
Minimum Split (s)	10.0	15.0	15.0	10.0	15.0	15.0	9.0	9.0	9.0	9.0	9.0	10.0
Total Split (s)	20.0	44.0	44.0	20.0	44.0	44.0	24.0	24.0	24.0	24.0	24.0	20.0
Total Split (%)	18.2%	40.0%	40.0%	18.2%	40.0%	40.0%	21.8%	21.8%	21.8%	21.8%	21.8%	18.2%
Yellow Time (s)	4.0	4.0	4.0	4.0	4.0	4.0	3.0	3.0	3.0	3.0	3.0	4.0
All-Red Time (s)	1.0	1.0	1.0	1.0	1.0	1.0	1.0	1.0	1.0	1.0	1.0	1.0
Lost Time Adjust (s)	-1.0	-1.0	-1.0	-1.0	-1.0	-1.0		0.0	0.0		0.0	0.0
Total Lost Time (s)	4.0	4.0	4.0	4.0	4.0	4.0		4.0	4.0		4.0	5.0
Lead/Lag	Lead	Lag	Lag	Lead	Lag	Lag						Lead
Lead-Lag Optimize?												
Recall Mode	None	None	None	None	None	None	None	None	None	None	None	None
v/c Ratio	0.64	0.56	0.05	0.05	0.92	0.20		0.30	0.11		0.71	0.32
Control Delay	26.8	14.8	0.1	8.1	39.5	7.3		37.1	0.6		52.5	3.4
Queue Delay	0.0	0.0	0.0	0.0	0.0	0.0		0.0	0.0		0.0	0.0
Total Delay	26.8	14.8	0.1	8.1	39.5	7.3		37.1	0.6		52.5	3.4
Queue Length 50th (ft)	52	114	0	3	360	13		25	0		75	0
Queue Length 95th (ft)	#203	#575	0	19	#967	70		75	0		176	34
Internal Link Dist (ft)		383			842			240			77	
Turn Bay Length (ft)	160		50	100		150			26			
Base Capacity (vph)	407	1193	1062	652	910	828		300	476		345	765
Starvation Cap Reductn	0	0	0	0	0	0		0	0		0	0
Spillback Cap Reductn	0	0	0	0	0	0		0	0		0	0
Storage Cap Reductn	0	0	0	0	0	0		0	0		0	0
Reduced v/c Ratio	0.54	0.56	0.05	0.04	0.92	0.20		0.19	0.08		0.46	0.30

Intersection Summary

Area Type: Other
 Cycle Length: 110

Lane Group	Ø9
Lane Configurations	
Traffic Volume (vph)	
Future Volume (vph)	
Ideal Flow (vphpl)	
Lane Width (ft)	
Storage Length (ft)	
Storage Lanes	
Taper Length (ft)	
Right Turn on Red	
Link Speed (mph)	
Link Distance (ft)	
Travel Time (s)	
Peak Hour Factor	
Heavy Vehicles (%)	
Shared Lane Traffic (%)	
Lane Group Flow (vph)	
Turn Type	
Protected Phases	9
Permitted Phases	
Detector Phase	
Switch Phase	
Minimum Initial (s)	4.0
Minimum Split (s)	21.0
Total Split (s)	22.0
Total Split (%)	20%
Yellow Time (s)	3.0
All-Red Time (s)	2.0
Lost Time Adjust (s)	
Total Lost Time (s)	
Lead/Lag	
Lead-Lag Optimize?	
Recall Mode	None
v/c Ratio	
Control Delay	
Queue Delay	
Total Delay	
Queue Length 50th (ft)	
Queue Length 95th (ft)	
Internal Link Dist (ft)	
Turn Bay Length (ft)	
Base Capacity (vph)	
Starvation Cap Reductn	
Spillback Cap Reductn	
Storage Cap Reductn	
Reduced v/c Ratio	
Intersection Summary	

2029 Build Weekday Evening Peak Hour
 2: CVS Dwy/Horace Mann Plaza Dwy & Route 140

01/18/2022

Actuated Cycle Length: 82.8

Natural Cycle: 90

Control Type: Actuated-Uncoordinated

95th percentile volume exceeds capacity, queue may be longer.

Queue shown is maximum after two cycles.

Splits and Phases: 2: CVS Dwy/Horace Mann Plaza Dwy & Route 140

 Ø1	 Ø2	 Ø4	 Ø9
20 s	44 s	24 s	22 s
 Ø5	 Ø6	 Ø8	
20 s	44 s	24 s	

2029 Build Weekday Evening Peak Hour
2: CVS Dwy/Horace Mann Plaza Dwy & Route 140

01/18/2022



Movement	EBL	EBT	EBR	WBL	WBT	WBR	NBL	NBT	NBR	SBL	SBT	SBR
Lane Configurations												
Traffic Volume (vph)	206	629	50	21	762	147	36	19	35	135	17	220
Future Volume (vph)	206	629	50	21	762	147	36	19	35	135	17	220
Ideal Flow (vphpl)	1900	1900	1900	1900	1900	1900	1900	1900	1900	1900	1900	1900
Lane Width	10	11	11	11	11	11	11	11	11	13	13	12
Total Lost time (s)	4.0	4.0	4.0	4.0	4.0	4.0		4.0	4.0		4.0	5.0
Lane Util. Factor	1.00	1.00	1.00	1.00	1.00	1.00		1.00	1.00		1.00	1.00
Frt	1.00	1.00	0.85	1.00	1.00	0.85		1.00	0.85		1.00	0.85
Flt Protected	0.95	1.00	1.00	0.95	1.00	1.00		0.97	1.00		0.96	1.00
Satd. Flow (prot)	1685	1818	1561	1745	1837	1561		1778	1561		1880	1615
Flt Permitted	0.08	1.00	1.00	0.35	1.00	1.00		0.66	1.00		0.71	1.00
Satd. Flow (perm)	147	1818	1561	634	1837	1561		1214	1561		1392	1615
Peak-hour factor, PHF	0.94	0.94	0.94	0.91	0.91	0.91	0.95	0.95	0.95	0.96	0.96	0.96
Adj. Flow (vph)	219	669	53	23	837	162	38	20	37	141	18	229
RTOR Reduction (vph)	0	0	21	0	0	55	0	0	32	0	0	165
Lane Group Flow (vph)	219	669	32	23	837	107	0	58	5	0	159	64
Heavy Vehicles (%)	0%	1%	0%	0%	0%	0%	0%	0%	0%	0%	0%	0%
Turn Type	pm+pt	NA	custom	pm+pt	NA	custom	Perm	NA	Perm	Perm	NA	pm+ov
Protected Phases	5	2	2	1	6	6		8			4	5
Permitted Phases	2		2	6		6	8		8	4		4
Actuated Green, G (s)	60.2	53.3	53.3	45.2	43.3	43.3		13.3	13.3		13.3	25.2
Effective Green, g (s)	61.2	54.3	54.3	47.2	44.3	44.3		13.3	13.3		13.3	25.2
Actuated g/C Ratio	0.68	0.60	0.60	0.53	0.49	0.49		0.15	0.15		0.15	0.28
Clearance Time (s)	5.0	5.0	5.0	5.0	5.0	5.0		4.0	4.0		4.0	5.0
Vehicle Extension (s)	2.0	2.0	2.0	2.0	2.0	2.0		2.0	2.0		2.0	2.0
Lane Grp Cap (vph)	320	1098	942	368	905	769		179	230		205	452
v/s Ratio Prot	c0.10	0.37	0.02	0.00	c0.46	0.07						0.02
v/s Ratio Perm	0.37			0.03				0.05	0.00		c0.11	0.02
v/c Ratio	0.68	0.61	0.03	0.06	0.92	0.14		0.32	0.02		0.78	0.14
Uniform Delay, d1	22.7	11.2	7.2	10.6	21.2	12.4		34.3	32.7		36.9	24.2
Progression Factor	1.00	1.00	1.00	1.00	1.00	1.00		1.00	1.00		1.00	1.00
Incremental Delay, d2	4.8	0.7	0.0	0.0	14.6	0.0		0.4	0.0		15.3	0.1
Delay (s)	27.5	11.8	7.2	10.6	35.9	12.4		34.7	32.8		52.2	24.3
Level of Service	C	B	A	B	D	B		C	C		D	C
Approach Delay (s)		15.2			31.6			33.9			35.7	
Approach LOS		B			C			C			D	

Intersection Summary

HCM 2000 Control Delay	26.0	HCM 2000 Level of Service	C
HCM 2000 Volume to Capacity ratio	0.84		
Actuated Cycle Length (s)	89.9	Sum of lost time (s)	18.0
Intersection Capacity Utilization	76.6%	ICU Level of Service	D
Analysis Period (min)	15		

c Critical Lane Group

2029 Build Weekday Evening Peak Hour
 3: Site Driveway & Route 140

01/18/2022



Lane Group	EBT	EBR	WBL	WBT	NBL	NBR
Lane Configurations						
Traffic Volume (vph)	837	14	9	937	9	6
Future Volume (vph)	837	14	9	937	9	6
Ideal Flow (vphpl)	1900	1900	1900	1900	1900	1900
Link Speed (mph)	30			30	30	
Link Distance (ft)	751			463	265	
Travel Time (s)	17.1			10.5	6.0	
Peak Hour Factor	0.92	0.92	0.92	0.92	0.92	0.92
Shared Lane Traffic (%)						
Lane Group Flow (vph)	925	0	0	1028	17	0
Sign Control	Free			Free	Stop	

Intersection Summary

Area Type: Other

Control Type: Unsignalized

2029 Build Weekday Evening Peak Hour
3: Site Driveway & Route 140

01/18/2022

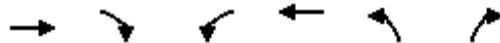

Movement	EBT	EBR	WBL	WBT	NBL	NBR
Lane Configurations	↔			↔	↔	
Traffic Volume (veh/h)	837	14	9	937	9	6
Future Volume (Veh/h)	837	14	9	937	9	6
Sign Control	Free			Free	Stop	
Grade	0%			0%	0%	
Peak Hour Factor	0.92	0.92	0.92	0.92	0.92	0.92
Hourly flow rate (vph)	910	15	10	1018	10	7
Pedestrians						
Lane Width (ft)						
Walking Speed (ft/s)						
Percent Blockage						
Right turn flare (veh)						
Median type	None			None		
Median storage (veh)						
Upstream signal (ft)	751			463		
pX, platoon unblocked			0.72		0.70	0.72
vC, conflicting volume			925		1956	918
vC1, stage 1 conf vol						
vC2, stage 2 conf vol						
vCu, unblocked vol			696		1235	686
tC, single (s)			4.1		6.4	6.2
tC, 2 stage (s)						
tF (s)			2.2		3.5	3.3
p0 queue free %			98		93	98
cM capacity (veh/h)			644		134	320
Direction, Lane #	EB 1	WB 1	NB 1			
Volume Total	925	1028	17			
Volume Left	0	10	10			
Volume Right	15	0	7			
cSH	1700	644	176			
Volume to Capacity	0.54	0.02	0.10			
Queue Length 95th (ft)	0	1	8			
Control Delay (s)	0.0	0.5	27.7			
Lane LOS		A	D			
Approach Delay (s)	0.0	0.5	27.7			
Approach LOS			D			
Intersection Summary						
Average Delay			0.5			
Intersection Capacity Utilization			66.5%		ICU Level of Service	C
Analysis Period (min)			15			

2029 Build with Mitigation



2029 Build Weekday Evening Peak Hour w/Mitigation

1: King St/Chestnut St & Route 140

01/18/2022

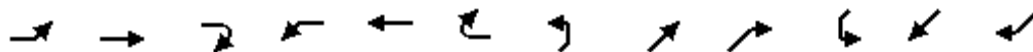

Lane Group	EBL	EBT	EBR	WBL	WBT	WBR	NEL	NET	NER	SWL	SWT	SWR
Lane Configurations												
Traffic Volume (vph)	163	475	45	403	488	55	33	302	342	34	336	129
Future Volume (vph)	163	475	45	403	488	55	33	302	342	34	336	129
Ideal Flow (vphpl)	1900	1900	1900	1900	1900	1900	1900	1900	1900	1900	1900	1900
Lane Width (ft)	12	11	11	11	11	11	11	11	11	16	16	16
Storage Length (ft)	100		50	165		50	0		80	0		0
Storage Lanes	1		0	1		0	0		1	0		0
Taper Length (ft)	25			25			25			25		
Right Turn on Red			Yes			Yes			Yes			Yes
Link Speed (mph)		30			30			30				30
Link Distance (ft)		639			751			457				724
Travel Time (s)		14.5			17.1			10.4				16.5
Peak Hour Factor	0.93	0.93	0.93	0.93	0.93	0.93	0.91	0.91	0.91	0.81	0.81	0.81
Heavy Vehicles (%)	0%	0%	0%	0%	0%	0%	4%	1%	1%	0%	1%	0%
Shared Lane Traffic (%)												
Lane Group Flow (vph)	175	559	0	433	584	0	0	368	376	0	616	0
Turn Type	pm+pt	NA		pm+pt	NA		Perm	NA	pm+ov	Perm	NA	
Protected Phases	5	2		1	6			8	1			4
Permitted Phases	2			6			8		8	4		
Detector Phase	5	2		1	6		8	8	1	4		4
Switch Phase												
Minimum Initial (s)	6.0	6.0		6.0	6.0		6.0	6.0	6.0	6.0	6.0	6.0
Minimum Split (s)	11.0	21.0		11.0	21.0		21.0	21.0	11.0	21.0	21.0	21.0
Total Split (s)	22.0	36.0		22.0	36.0		37.0	37.0	22.0	37.0	37.0	37.0
Total Split (%)	18.8%	30.8%		18.8%	30.8%		31.6%	31.6%	18.8%	31.6%	31.6%	31.6%
Yellow Time (s)	3.0	3.0		3.0	3.0		3.0	3.0	3.0	3.0	3.0	3.0
All-Red Time (s)	2.0	2.0		2.0	2.0		2.0	2.0	2.0	2.0	2.0	2.0
Lost Time Adjust (s)	-1.0	-1.0		-1.0	-1.0			-1.0	-1.0			-1.0
Total Lost Time (s)	4.0	4.0		4.0	4.0			4.0	4.0			4.0
Lead/Lag	Lead	Lag		Lead	Lag				Lead			
Lead-Lag Optimize?	Yes	Yes		Yes	Yes				Yes			
Recall Mode	None	None		None	None		None	None	None	None	None	None
v/c Ratio	0.56	0.95		1.11	0.83			0.75	0.39			1.11
Control Delay	21.2	60.0		106.4	40.7			42.0	6.0			103.6
Queue Delay	0.0	0.0		0.0	0.0			0.0	0.0			0.0
Total Delay	21.2	60.0		106.4	40.7			42.0	6.0			103.6
Queue Length 50th (ft)	47	318		~240	296			191	33			~409
Queue Length 95th (ft)	122	#698		#582	#740			#439	126			#691
Internal Link Dist (ft)		559			671			377				644
Turn Bay Length (ft)	100			165					80			
Base Capacity (vph)	427	591		391	704			489	972			556
Starvation Cap Reductn	0	0		0	0			0	0			0
Spillback Cap Reductn	0	0		0	0			0	0			0
Storage Cap Reductn	0	0		0	0			0	0			0
Reduced v/c Ratio	0.41	0.95		1.11	0.83			0.75	0.39			1.11

Intersection Summary

Area Type: Other

Cycle Length: 117

2029 Build Weekday Evening Peak Hour w/Mitigation
 1: King St/Chestnut St & Route 140

01/18/2022

Lane Group	Ø9
Lane Configurations	
Traffic Volume (vph)	
Future Volume (vph)	
Ideal Flow (vphpl)	
Lane Width (ft)	
Storage Length (ft)	
Storage Lanes	
Taper Length (ft)	
Right Turn on Red	
Link Speed (mph)	
Link Distance (ft)	
Travel Time (s)	
Peak Hour Factor	
Heavy Vehicles (%)	
Shared Lane Traffic (%)	
Lane Group Flow (vph)	
Turn Type	
Protected Phases	9
Permitted Phases	
Detector Phase	
Switch Phase	
Minimum Initial (s)	4.0
Minimum Split (s)	21.0
Total Split (s)	22.0
Total Split (%)	19%
Yellow Time (s)	3.0
All-Red Time (s)	2.0
Lost Time Adjust (s)	
Total Lost Time (s)	
Lead/Lag	
Lead-Lag Optimize?	
Recall Mode	None
v/c Ratio	
Control Delay	
Queue Delay	
Total Delay	
Queue Length 50th (ft)	
Queue Length 95th (ft)	
Internal Link Dist (ft)	
Turn Bay Length (ft)	
Base Capacity (vph)	
Starvation Cap Reductn	
Spillback Cap Reductn	
Storage Cap Reductn	
Reduced v/c Ratio	
Intersection Summary	

2029 Build Weekday Evening Peak Hour w/Mitigation
 1: King St/Chestnut St & Route 140

01/18/2022

Actuated Cycle Length: 99.2

Natural Cycle: 150

Control Type: Actuated-Uncoordinated







~ Volume exceeds capacity, queue is theoretically infinite.

Queue shown is maximum after two cycles.

95th percentile volume exceeds capacity, queue may be longer.

Queue shown is maximum after two cycles.

Splits and Phases: 1: King St/Chestnut St & Route 140

 Ø4	 Ø1	 Ø2	 Ø9
37 s	22 s	36 s	22 s
 Ø8	 Ø5	 Ø6	
37 s	22 s	36 s	

2029 Build Weekday Evening Peak Hour w/Mitigation

1: King St/Chestnut St & Route 140

01/18/2022

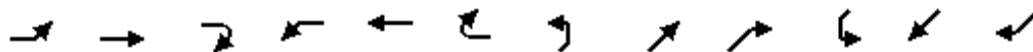

Movement	EBL	EBT	EBR	WBL	WBT	WBR	NEL	NET	NER	SWL	SWT	SWR
Lane Configurations												
Traffic Volume (vph)	163	475	45	403	488	55	33	302	342	34	336	129
Future Volume (vph)	163	475	45	403	488	55	33	302	342	34	336	129
Ideal Flow (vphpl)	1900	1900	1900	1900	1900	1900	1900	1900	1900	1900	1900	1900
Lane Width	12	11	11	11	11	11	11	11	11	16	16	16
Total Lost time (s)	4.0	4.0		4.0	4.0			4.0	4.0		4.0	
Lane Util. Factor	1.00	1.00		1.00	1.00			1.00	1.00		1.00	
Frt	1.00	0.99		1.00	0.98			1.00	0.85		0.97	
Flt Protected	0.95	1.00		0.95	1.00			1.00	1.00		1.00	
Satd. Flow (prot)	1805	1813		1745	1809			1804	1546		2057	
Flt Permitted	0.16	1.00		0.11	1.00			0.81	1.00		0.79	
Satd. Flow (perm)	300	1813		203	1809			1461	1546		1630	
Peak-hour factor, PHF	0.93	0.93	0.93	0.93	0.93	0.93	0.91	0.91	0.91	0.81	0.81	0.81
Adj. Flow (vph)	175	511	48	433	525	59	36	332	376	42	415	159
RTOR Reduction (vph)	0	3	0	0	3	0	0	0	125	0	10	0
Lane Group Flow (vph)	175	556	0	433	581	0	0	368	251	0	606	0
Heavy Vehicles (%)	0%	0%	0%	0%	0%	0%	4%	1%	1%	0%	1%	0%
Turn Type	pm+pt	NA		pm+pt	NA		Perm	NA	pm+ov	Perm	NA	
Protected Phases	5	2		1	6			8	1		4	
Permitted Phases	2			6			8		8	4		
Actuated Green, G (s)	42.0	31.2		53.3	37.5			32.2	49.3		32.2	
Effective Green, g (s)	44.0	32.2		54.3	38.5			33.2	51.3		33.2	
Actuated g/C Ratio	0.43	0.31		0.53	0.37			0.32	0.50		0.32	
Clearance Time (s)	5.0	5.0		5.0	5.0			5.0	5.0		5.0	
Vehicle Extension (s)	3.0	3.0		3.0	3.0			3.0	3.0		3.0	
Lane Grp Cap (vph)	299	565		377	674			470	828		524	
v/s Ratio Prot	0.07	0.31		c0.20	0.32				0.05			
v/s Ratio Perm	0.18			c0.40				0.25	0.11		c0.37	
v/c Ratio	0.59	0.98		1.15	0.86			0.78	0.30		1.16	
Uniform Delay, d1	21.4	35.3		31.2	29.9			31.7	15.4		35.0	
Progression Factor	1.00	1.00		1.00	1.00			1.00	1.00		1.00	
Incremental Delay, d2	2.9	33.6		93.3	11.0			8.3	0.2		90.1	
Delay (s)	24.4	68.9		124.5	40.9			40.0	15.6		125.1	
Level of Service	C	E		F	D			D	B		F	
Approach Delay (s)		58.3			76.5			27.7			125.1	
Approach LOS		E			E			C			F	

Intersection Summary

HCM 2000 Control Delay	70.1	HCM 2000 Level of Service	E
HCM 2000 Volume to Capacity ratio	1.15		
Actuated Cycle Length (s)	103.2	Sum of lost time (s)	17.0
Intersection Capacity Utilization	108.5%	ICU Level of Service	G
Analysis Period (min)	15		

c Critical Lane Group