

**LOCUS MAP**  
NOT TO SCALE

# SITE DEVELOPMENT PLANS FOR 25 FORGE PARKWAY FRANKLIN, MA 02038 TAX MAP 275, LOT 14

**APPLICANT/OWNER:**  
TMC HOLDINGS & DEVELOPMENT 2, LLC  
25 FORGE PARKWAY  
FRANKLIN, MA 02038

**CIVIL ENGINEER:**  
ALLEN & MAJOR ASSOCIATES, INC.  
400 HARVEY ROAD  
MANCHESTER, NH 03103

**SURVEYOR:**  
ALLEN & MAJOR ASSOCIATES, INC.  
100 COMMERCE WAY  
WOBURN, MA 01801

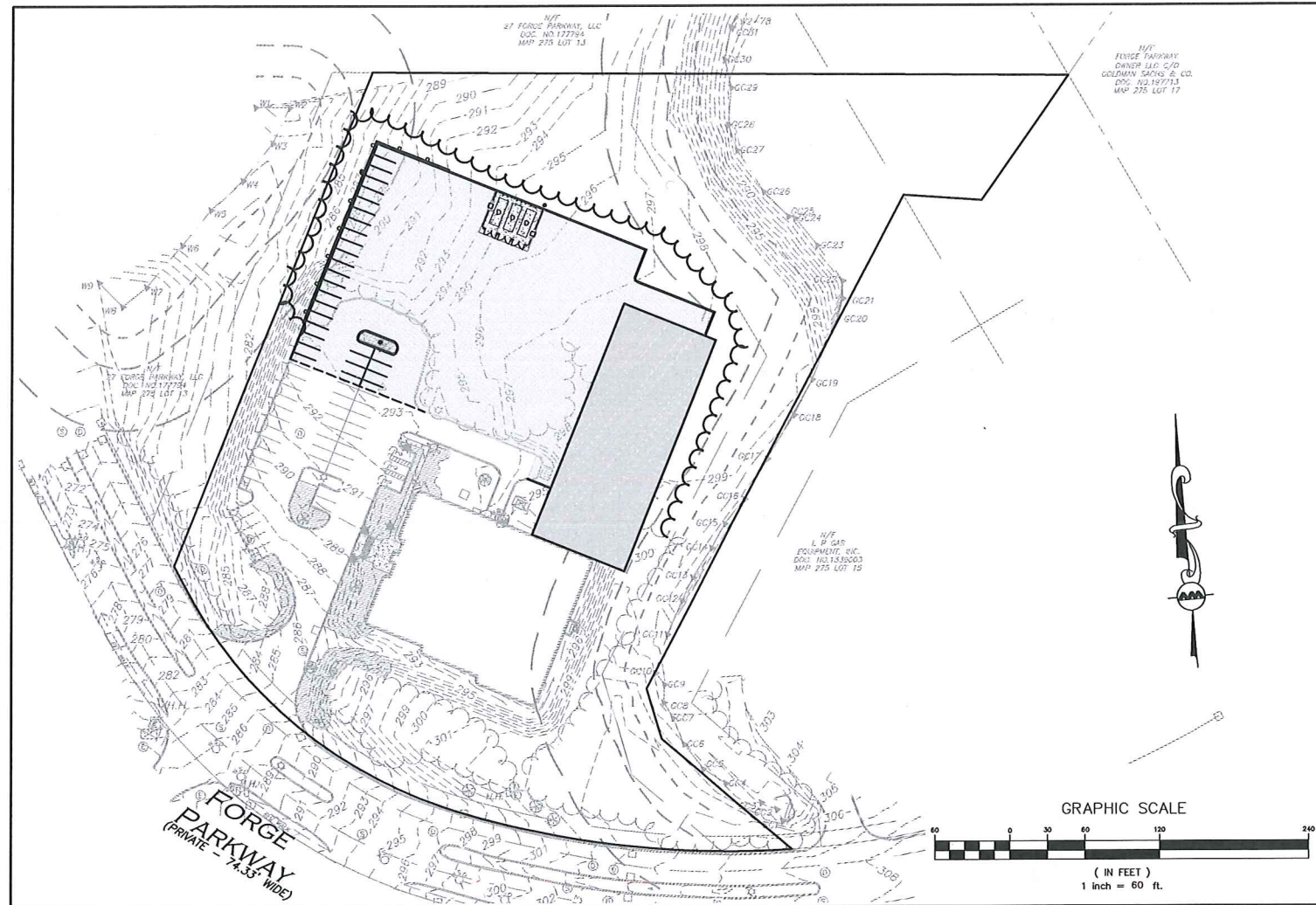

**LIST OF DRAWINGS**

DRAWING TITLE	SHEET NO.	ISSUED	REVISION 1
EXISTING CONDITIONS	V-101	02-21-23	04-04-23
EROSION CONTROL & SITE PREPARATION NOTES	C-001	-	04-04-23
SITE PREPARATION PLAN	C-101	02-21-23	04-04-23
LAYOUT & MATERIALS PLAN	C-102	02-21-23	04-04-23
GRADING & DRAINAGE PLAN	C-103	02-21-23	04-04-23
LIGHTING PLAN	C-104	02-21-23	04-04-23
DETAILS	C-501	02-21-23	04-04-23
DETAILS	C-502	02-21-23	04-04-23
DETAILS	C-503	02-21-23	04-04-23
LANDSCAPE PLAN	L-101	-	04-04-23
LANDSCAPE NOTES & DETAILS	L-501	-	04-04-23

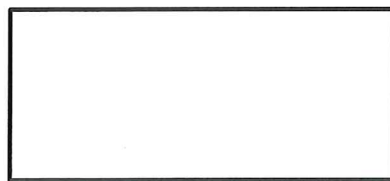

TOWN OF FRANKLIN APPROVAL STAMP



*Brian D. Jones*  
07-04-23  
PROFESSIONAL ENGINEER FOR  
ALLEN & MAJOR ASSOCIATES, INC.



**ALLEN & MAJOR ASSOCIATES, INC.**  
civil engineering • land surveying  
environmental consulting • landscape architecture  
www.allenmajor.com

100 COMMERCE WAY, SUITE 5  
WOBURN MA 01801  
TEL: (781) 935-6889  
FAX: (781) 935-2896

WOBURN, MA • LAKEVILLE, MA • MANCHESTER, NH  
Copyright ©2023 Allen & Major Associates, Inc.  
All Rights Reserved

ISSUED FOR INITIAL REVIEW: FEBRUARY 21, 2023  
REVISION 1: APRIL 4, 2023



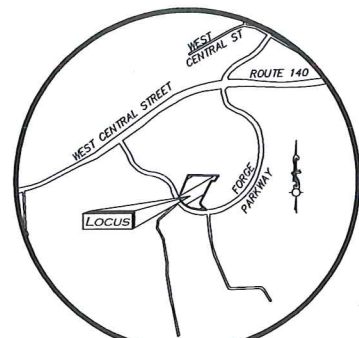

LOCUS MAP  
(NOT TO SCALE)

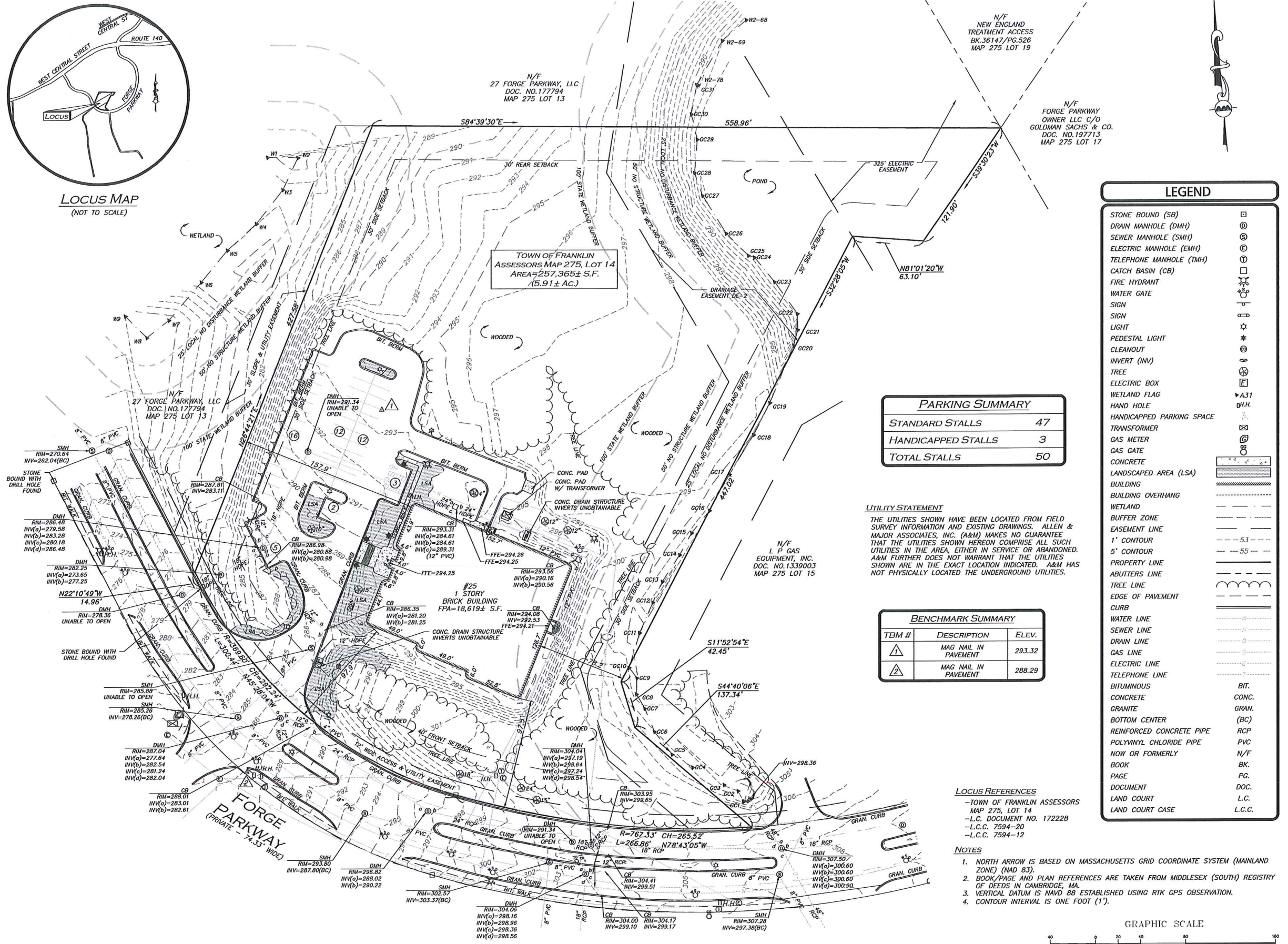

TOWN OF FRANKLIN  
ASSESSORS MAP 275, LOT 14  
AREA=257,365± S.F.  
(5.91± Ac.)

PARKING SUMMARY	
STANDARD STALLS	47
HANDICAPPED STALLS	3
TOTAL STALLS	50

**UTILITY STATEMENT**  
THE UTILITIES SHOWN HAVE BEEN LOCATED FROM FIELD SURVEY INFORMATION AND EXISTING DRAWINGS. ALLEN & MAJOR ASSOCIATES, INC. (A&M) MAKES NO GUARANTEE THAT THE UTILITIES SHOWN HEREON COMPRISE ALL SUCH UTILITIES IN THE AREA, EITHER IN SERVICE OR ABANDONED. A&M FURTHER DOES NOT WARRANT THAT THE UTILITIES SHOWN ARE IN THE EXACT LOCATION INDICATED. A&M HAS NOT PHYSICALLY LOCATED THE UNDERGROUND UTILITIES.

BENCHMARK SUMMARY		
TBM #	DESCRIPTION	ELEV.
1	MAG NAIL IN PAVEMENT	293.32
2	MAG NAIL IN PAVEMENT	288.29

**LOCUS REFERENCES**  
-TOWN OF FRANKLIN ASSESSORS MAP 275, LOT 14  
-L.C. DOCUMENT NO. 172228  
-L.C. 7594-20  
-L.C. 7594-12

- NOTES**
- NORTH ARROW IS BASED ON MASSACHUSETTS GRID COORDINATE SYSTEM (MAINLAND ZONE) (NAD 83).
  - BOOK/PAGE AND PLAN REFERENCES ARE TAKEN FROM MIDDLESEX (SOUTH) REGISTRY OF DEEDS IN CAMBRIDGE, MA.
  - VERTICAL DATUM IS NAVD 88 ESTABLISHED USING RTK GPS OBSERVATION.
  - CONTOUR INTERVAL IS ONE FOOT (1').

LEGEND	
STONE BOUND (SB)	□
DRAIN MANHOLE (DMH)	⊙
SEWER MANHOLE (SMH)	⊕
ELECTRIC MANHOLE (EMH)	⊖
TELEPHONE MANHOLE (TMH)	⊗
CATCH BASIN (CB)	⊠
FIRE HYDRANT	⊕
WATER GATE	⊖
SIGN	⊠
SIGN	⊠
LIGHT	☆
PEDESTAL LIGHT	⊕
CLEANOUT	⊖
INVERT (INV)	⊖
TREE	⊕
ELECTRIC BOX	⊕
WETLAND FLAG	⊕
HAND HOLE	⊕
HANDICAPPED PARKING SPACE	⊕
TRANSFORMER	⊕
GAS METER	⊕
GAS GATE	⊕
CONCRETE	⊕
LANDSCAPED AREA (LSA)	⊕
BUILDING	⊕
BUILDING OVERHANG	⊕
WETLAND	⊕
BUFFER ZONE	⊕
EASEMENT LINE	⊕
1' CONTOUR	⊕
5' CONTOUR	⊕
PROPERTY LINE	⊕
ABUTTERS LINE	⊕
TREE LINE	⊕
EDGE OF PAVEMENT	⊕
CURB	⊕
WATER LINE	⊕
SEWER LINE	⊕
DRAIN LINE	⊕
GAS LINE	⊕
ELECTRIC LINE	⊕
TELEPHONE LINE	⊕
BITUMINOUS	⊕
CONCRETE	⊕
GRANITE	⊕
BOTTOM CENTER	⊕
REINFORCED CONCRETE PIPE	⊕
POLYVINYL CHLORIDE PIPE	⊕
NOW OR FORMERLY	⊕
BOOK	⊕
PAGE	⊕
DOCUMENT	⊕
LAND COURT	⊕
LAND COURT CASE	⊕

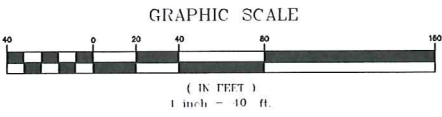

WE HEREBY CERTIFY THAT THIS PLAN IS THE RESULT OF AN ACTUAL ON THE GROUND SURVEY PERFORMED ON OR BETWEEN APRIL 1, 2021 AND FEBRUARY 15, 2023.

Apr. 4, 2023

PROFESSIONAL LAND SURVEYOR FOR ALLEN & MAJOR ASSOCIATES, INC.



REV	DATE	DESCRIPTION
1.	04/04/23	PEER REVIEW COMMENTS

APPLICANT/OWNER:  
**GREEN SITE SERVICES GROUP**  
24 WILLIAM WAY  
BELLINGHAM, MA 02019

PROJECT:  
**25 FORGE PARKWAY**  
FRANKLIN, MA

PROJECT NO. 2712-02 DATE: 2/15/23  
SCALE: 1" = 40' DWG. NAME: S-2712-02-EC  
DRAFTED BY: AIR CHECKED BY: NIL

PREPARED BY:

**ALLEN & MAJOR ASSOCIATES, INC.**  
civil engineering • landscape surveying  
environmental consulting • landscape architecture  
www.allenmajor.com  
100 COMMERCE WAY  
WOBURN MA 01801-8501  
TEL: (781) 935-6889  
FAX: (781) 935-2896

WOBURN, MA • LAKEVILLE, MA • MANCHESTER, NH

THIS DRAWING HAS BEEN PREPARED IN DIGITAL FORMAT. CLIENTS/CLIENTS REPRESENTATIVE OR CONSULTANTS MAY BE PROVIDED COPIES OF DRAWINGS AND SPECIFICATIONS FOR HIS/HER INFORMATION AND/OR SPECIFIC USE ON THIS PROJECT. DUE TO THE POTENTIAL THAT THE PROVIDED INFORMATION MAY BE MODIFIED UNINTENTIONALLY OR OTHERWISE, ALLEN & MAJOR ASSOCIATES, INC. MAY REMOVE ALL INDICATION OF THE DOCUMENT'S AUTHORITY ON THE DIGITAL MEDIA. PRINTED REPRESENTATIONS OR PORTABLE DOCUMENT FORMAT OF THE DRAWINGS AND SPECIFICATIONS ISSUED SHALL BE THE ONLY RECORD COPIES OF ALLEN & MAJOR ASSOCIATES, INC.'S WORK PRODUCT.

DRAWING TITLE: **EXISTING CONDITIONS** SHEET No. **V-101**



# EROSION CONTROL NOTES

## EROSION & SEDIMENTATION CONTROL NOTES:

1. EROSION CONTROL SHALL BE INSTALLED PRIOR TO CONSTRUCTION AND SHALL BE ADEQUATE TO MAINTAIN SEDIMENT ON SITE. ANY MODIFICATIONS TO SILT CONTROLS SHOWN ON THE APPROVED PLANS AS A RESULT OF ACTUAL FIELD CONDITIONS OR CONSTRUCTION PRACTICES SHALL BE INSTALLED IN ACCORDANCE WITH B.M.P. (BEST MANAGEMENT PRACTICES) PER THE E.P.A. 2022 "CONSTRUCTION GENERAL PERMIT" MANUAL, AND MASSACHUSETTS 2003 EROSION & SEDIMENT CONTROL GUIDELINES FOR URBAN AND SUBURBAN AREAS. ANY SUCH MODIFICATIONS FROM THE ABOVE MANUALS SHALL BE INSTALLED AS APPROVED BY THE ENGINEER OR THE LOCAL MUNICIPALITY.
2. AREAS OF EXPOSED SOIL UNDERGOING CONSTRUCTION THAT WILL NOT BE COVERED AND OR FINISHED GRADED SHALL BE STABILIZED AS SOON AS PRACTICABLE BUT IN NO CASE MORE THAN 14 DAYS AFTER THE CONSTRUCTION ACTIVITY (UNLESS MUNICIPALITY HAS STRICTER REQUIREMENTS WHICH SHALL BE FOLLOWED) IN THAT PORTION OF THE SITE HAS TEMPORARILY OR PERMANENTLY CEASED. TEMPORARY EROSION CONTROL MEASURES SHALL INCLUDE EROSION CONTROL MESH, NETTING OR MULCH AS DIRECTED BY THE OWNER'S REPRESENTATIVE AND SHOWN ON THE DESIGN PLANS. IF MULCH IS USED, STRAW MULCH SHALL BE APPLIED AT THE RATE OF 4 BALES PER 1,000 SQUARE FEET. APPLICATION AREA SHALL BE SUFFICIENTLY COVERED WITH MULCH TO AVOID ANY VISIBLE SOIL EXPOSURE. MULCH SHALL BE KEPT MOIST TO AVOID LOSS DUE TO WIND. MULCH AND NETTING SHALL BE APPLIED IN THE BASE OF ALL GRASSED WATERWAYS, IN VEGETATIVE SLOPES WHICH EXCEED 15% AND DISTURBED AREAS WITHIN 100 FEET OF WETLANDS OR STREAMS.
3. IF DISTURBED AREAS DO NOT RECEIVE FINAL SEEDING BY OCTOBER 1ST OF THE CONSTRUCTION YEAR, THEN ALL DISTURBED AREAS SHALL BE SEEDED WITH A WINTER COVER CROP AT THE RATE OF 3 LBS PER 1,000 SQUARE FEET. WINTER SEEDING SHALL BE COVERED WITH EROSION CONTROL MESH (MULCH AND NETTING). HEAVY GRADE MATS SHALL BE USED IN THE BASE OF ALL GRASSED WATERWAYS ON VEGETATED SLOPES IN EXCESS OF 15%, AND IN DISTURBED AREAS WITHIN 100 FEET OF WETLANDS OR STREAMS. MULCH AND NETTING SHALL ALSO BE PROVIDED FOR ADDITIONAL WINTER PROTECTION.
4. ALL TOPSOIL SHALL BE COLLECTED, STOCKPILED, SEEDED WITH RYE AT 3LBS PER 1,000 SQUARE FOOT AND MULCHED, AND REUSED AS REQUIRED. TUBULAR BARRIERS SHALL BE PLACED DOWN GRADIENT FROM STOCKPILED LOAM. LOAM SHALL BE STOCKPILED AT LOCATIONS DESIGNATED BY THE OWNER AND ENGINEER.
5. ALL TUBULAR BARRIERS, SILT SACKS, AND EROSION CONTROL BERMS SHALL BE INSTALLED ACCORDING TO THE SITE PREPARATION PLAN. THESE SHALL BE MAINTAINED DURING DEVELOPMENT TO REMOVE SEDIMENT FROM RUNOFF WATER. ALL THE FILTER BARRIERS AND EROSION CONTROL BERMS SHALL BE INSPECTED AFTER ANY RAINFALL OR RUNOFF EVENT, MAINTAINED AND CLEANED UNTIL ALL AREAS HAVE AT LEAST 85-90% VIGOROUS PERENNIAL COVER OF GRASSES.
6. ADJACENT ROADS SHALL BE PERIODICALLY SWEEPED OR WASHED TO AVOID TRACKING MUD, DUST OR DEBRIS FROM THE CONSTRUCTION AREA AS OFTEN AS NECESSARY (WHICH COULD BE ON A DAILY BASIS) TO REMOVE ANY SOIL OR SEDIMENTS AT NO ADDITIONAL COST TO THE OWNER. A WATERING TRUCK WILL BE USED TO PERIODICALLY SPRINKLE CONSTRUCTION AREAS IN ORDER TO KEEP THE LEVEL OF DUST TO A MINIMUM DURING THE DRY MONTHS AT NO ADDITIONAL COST TO THE OWNER.
7. THE CONTRACTOR SHALL USE EXTREME CAUTION TO AVOID ALLOWING SEDIMENTS TO ENTER THE STORM DRAIN SYSTEM DURING CONSTRUCTION. BOTH EXISTING AND PROPOSED CATCH BASIN INLETS SHALL BE PROTECTED DURING CONSTRUCTION BY THE USE SILT SACKS AND/OR TUBULAR BARRIERS AROUND EACH INLET AS NOTED ON THE PLANS. INLET PROTECTION MAY BE REMOVED ONLY AFTER FINISHED AREAS ARE PAVED AND THE VEGETATED SLOPES ARE ESTABLISHED WITH AT LEAST 85-90% OF VIGOROUS PERENNIAL GROWTH.
8. AS APPLICABLE, EROSION CONTROL MESH SHALL BE APPLIED IN ACCORDANCE WITH THE PLANS OVER ALL FINISHED SEEDING AREAS AS SPECIFIED ON THE DESIGN PLANS.
9. AT A MINIMUM, ALL TUBULAR BARRIERS AND FILTER FABRIC SHALL REMAIN IN PLACE UNTIL SEEDINGS OR PLANTINGS HAVE BECOME 85-90% ESTABLISHED. THE LOCAL CONSERVATION COMMISSION MUST APPROVE THE REMOVAL OR RELOCATION OF ANY OF THE TUBULAR BARRIERS AND FILTER FABRIC. ONCE THE TUBULAR BARRIERS ARE REMOVED THE AREAS ARE TO BE LOAMED AND SEEDED TO ACHIEVE FULL STABILIZATION.
10. AT THE OWNER'S DISCRETION ADDITIONAL EROSION CONTROL MEASURES MAY BE REQUIRED TO MAINTAIN STABILITY OF EARTHWORKS AND FINISHED GRADED AREAS. THE CONTRACTOR, AT HIS EXPENSE, WILL BE RESPONSIBLE FOR PROVIDING AND INSTALLING ANY ADDITIONAL MEASURES AS SPECIFIED BY THE OWNER. THIS INCLUDES BUT IS NOT LIMITED TO REQUESTS BY MA DEP, THE ENGINEER AND THE LOCAL MUNICIPALITY, AS AUTHORIZED BY THE OWNER. FAILURE TO COMPLY WITH THE OWNER'S DIRECTIONS WILL RESULT IN DISCONTINUATION OF CONSTRUCTION ACTIVITIES.
11. INSPECTIONS AND MONITORING MAINTENANCE MEASURES SHALL BE APPLIED AS NEEDED DURING THE ENTIRE CONSTRUCTION CYCLE. WEEKLY INSPECTIONS SHALL BE HELD THROUGH THE DURATION OF CONSTRUCTION ACTIVITY. WEEKLY INSPECTION REPORTS SHALL BE MAINTAINED BY THE CONTRACTOR AND LOCATED IN THE CONTRACTORS FIELD OFFICE ONSITE. IN ADDITION TO THE NORMAL WEEKLY INSPECTIONS, THE CONTRACTOR SHALL PERFORM AN INSPECTION OF ALL EROSION CONTROL MEASURES AFTER EACH RAINFALL OF 0.25" OR MORE, AND PERFORM THE NECESSARY REPAIRS. THE INSPECTIONS SHALL INCLUDE BUT NOT BE LIMITED TO THE SITE'S DOWN STREAM DISCHARGE POINTS.
12. IF ANY EVIDENCE OF SEDIMENTATION IS OBSERVED AT THE STORMWATER MANAGEMENT AREA INLETS, THE CONTRACTOR SHALL, AT HIS OWN EXPENSE, PROVIDE A PLAN TO THE ENGINEER TO REMOVE ANY ACCUMULATED SEDIMENT IN THESE AREAS. THE CONTRACTOR SHALL ALSO IMMEDIATELY PROVIDE ADDITIONAL ON SITE EROSION AND SEDIMENTATION CONTROL MEASURES TO PREVENT FURTHER DEGRADATION OF THE AREA.
13. FOLLOWING THE TEMPORARY OR FINAL SEEDINGS, THE CONTRACTOR SHALL INSPECT THE WORK AREAS SEMI-MONTHLY TO ENSURE THE AREAS HAVE A MINIMUM OF 85-90% VEGETATED VIGOROUS GROWTH. RE-SEEDING SHALL BE CARRIED OUT BY THE CONTRACTOR WITH FOLLOW UP INSPECTIONS IN THE EVENT OF ANY FAILURES UNTIL VEGETATION IS ADEQUATELY ESTABLISHED.
14. CONTRACTOR & ALL SITE SUBCONTRACTORS SHALL BE FAMILIAR WITH & FOLLOW ALL APPROVED PERMITS AND CONDITIONS. CONTRACTOR SHALL MAINTAIN A COPY OF ALL APPROVED PERMITS ONSITE. ALL CONDITIONS & RECOMMENDATIONS WITHIN THE APPROVED PERMITS SHALL BE COMPLETED.
15. ALL EROSION MEASURES SHALL BE INSTALLED PRIOR TO CONSTRUCTION AND SHALL BE ADEQUATE TO MAINTAIN SEDIMENT ON SITE. ANY MODIFICATIONS SHALL BE INSTALLED AS DIRECTED BY THE ENGINEER OR THE LOCAL MUNICIPALITY.
16. EROSION AND SEDIMENTATION CONTROL MEASURES SHALL BE MAINTAINED DURING CONSTRUCTION, AND SHALL REMAIN IN PLACE UNTIL ALL SITE WORK IS COMPLETE AND GROUND COVER IS ESTABLISHED.
17. TOP OF STOCKPILES SHALL BE COVERED IN SUCH MANNER THAT STORMWATER DOES NOT INFILTRATE THE MATERIALS AND THEREBY RENDER THE SAME UNSUITABLE FOR FILL USE.

## EROSION & SEDIMENTATION CONTROL NOTES (CONTINUED):

18. ALL DISTURBED OR EXPOSED AREAS SUBJECT TO EROSION SHALL BE STABILIZED WITH MULCH OR SEEDED FOR TEMPORARY VEGETATIVE COVER. NO AREA, SUBJECT TO EROSION SHALL BE LEFT DISTURBED AND UNSTABILIZED FOR PERIODS LONGER THAN IS ABSOLUTELY NECESSARY TO CARRY OUT THAT PORTION OF THE CONSTRUCTION WORK OR SIX MONTHS AFTER SOIL HAS BEEN DISTURBED WHICHEVER IS LESS.
19. CULVERT/PIPE INLETS AND OUTFALLS SHALL BE PROTECTED BY TUBULAR BARRIER FILTERS AND STONE CHECK DAMS UNTIL DISTURBED AREAS ARE PERMANENTLY STABILIZED.
20. TUBULAR BARRIER DIKES SHALL BE CONSTRUCTED AT ALL EXISTING & PROPOSED CATCH BASINS. NO SEDIMENTATION SHALL ENTER THE ON-SITE OR OFF-SITE DRAINAGE SYSTEMS AT ANY TIME.
21. ALL EROSION CONTROL MEASURES SHALL BE ROUTINELY INSPECTED, CLEANED AND REPAIRED OR REPLACED AS NECESSARY THROUGHOUT ALL PHASES OF CONSTRUCTION. IN ADDITION, INSPECTIONS SHALL TAKE PLACE WEEKLY AND BEFORE AND AFTER EACH RAINFALL EVENT.
22. ALL PROPOSED SLOPES STEEPER THAN 3:1 SHALL BE STABILIZED WITH JUTE MESH AND PROTECTED FROM EROSION UNTIL WORK IS COMPLETE AND GROUND COVER IS ESTABLISHED.
23. THE CONTRACTOR SHALL KEEP ON SITE AT ALL TIMES ADDITIONAL TUBULAR BARRIERS FOR INSTALLATION AT THE DIRECTION OF THE ENGINEER OR THE TOWN ENGINEER TO MITIGATE ANY EMERGENCY CONDITION.
24. AS CONSTRUCTION DISTURBANCE IS GREATER THAN 1 ACRE, A NATIONAL POLLUTANT DISCHARGE ELIMINATION SYSTEM (NPDES) CONSTRUCTION GENERAL PERMIT NOI, AND STORM WATER POLLUTION PREVENTION PLAN (SWPPP) WILL NEED TO BE SUBMITTED TO THE EPA, THE NPDES PERMIT FOR STORM WATER DISCHARGE, & CONSTRUCTION GENERAL PERMIT NOI WILL BE REQUIRED TO BE SUBMITTED AT LEAST 14 DAYS PRIOR TO COMMENCING CONSTRUCTION BY THE CONTRACTOR.
25. OWNER AND CONTRACTOR ARE RESPONSIBLE FOR COMPLIANCE WITH THE CONSTRUCTION GENERAL PERMIT NOI. WEEKLY SWPPP INSPECTION REPORTS TO BE PERFORMED BY CONTRACTOR. COPIES OF ALL SWPPP INSPECTION REPORTS SHALL BE PROVIDED TO THE LOCAL MUNICIPALITY, EPA, DEP, OR ANY OTHER AUTHORITY REQUESTING WITHIN 3 DAYS OF EACH INSPECTION.
26. APPLICABLE WORK AND MATERIALS SHALL COMPLY WITH ALL LOCAL, MA DEP, EPA CONSTRUCTION GENERAL PERMIT STANDARDS. ALL CONSTRUCTION SHALL CONFORM TO THE APPLICABLE SITE PLAN REGULATIONS FROM THE LOCAL AND USDA SOIL CONSERVATION SERVICE VEGETATIVE PRACTICES IN SITE DEVELOPMENT.
27. A WATERING TRUCK SHALL BE USED TO PERIODICALLY SPRINKLE CONSTRUCTION AREAS IN ORDER TO KEEP THE LEVEL OF DUST TO A MINIMUM DURING THE DRY MONTHS AND AS REQUIRED.
28. IF DEWATERING IS NECESSARY IT SHALL ONLY BE COMPLETED AS FOLLOWS: THE DISCHARGE SHALL BE STOPPED IMMEDIATELY IF THE RECEIVING AREA SHOWS ANY SIGN OF INSTABILITY OR EROSION. ALL CHANNELS, SWALES, AND DITCHES DUG FOR DISCHARGING WATER FROM THE EXCAVATED AREA SHALL BE STABLE PRIOR TO DIRECTING DISCHARGE TO THEM. IF A CONSTRUCTION EQUIPMENT BUCKET IS USED, IT SHALL EMPTY THE MATERIAL TO A STABLE AREA. NO DEWATERING SHALL OCCUR DURING PERIODS OF INTENSE, HEAVY RAIN. FLOW TO THE SEDIMENT REMOVAL STRUCTURE SHALL NOT EXCEED THE STRUCTURE'S CAPACITY TO SETTLE AND FILTER FLOW OR ITS VOLUME CAPACITY. WHENEVER POSSIBLE, THE DISCHARGE FROM THE SEDIMENT REMOVAL STRUCTURE SHALL DRAIN TO A WELL-VEGETATED BUFFER BY SHEET FLOW WHILE MAXIMIZING THE DISTANCE TO THE NEAREST WATER RESOURCE AND MINIMIZING THE SLOPE OF THE BUFFER AREA. THERE SHALL BE NO DIRECT DISCHARGE TO EXISTING WETLANDS OR STREAMS. ALL DISCHARGE SHALL BE IN COMPLIANCE WITH STATE, LOCAL, AND FEDERAL REQUIREMENTS.
29. INITIATE STABILIZATION OF EXPOSED AREAS IMMEDIATELY IF CONSTRUCTION WORK TEMPORARILY OR PERMANENTLY CEASES.
30. ALL DISCHARGES FROM POLLUTION SOURCES ARE PROHIBITED ONSITE SUCH AS FUELS, WASTEWATER FROM WASH OUT OF CONCRETE, WASTEWATER FROM CLEAN OUT OF PAINTS, FORM RELEASE OILS, SOLVENTS, ADHESIVES, CURING COMPOUNDS, POLLUTANTS USED FOR MAINTENANCE OF VEHICLES AND EQUIPMENT, SOAPS & SOLVENTS, TOXIC OR HAZARDOUS SUBSTANCES, CHEMICALS AND OILS. IF A POLLUTANT IS DISCHARGED IT NEEDS TO BE IMMEDIATELY CLEANED UP BY REMOVING THE CHEMICAL AND AFFECTED SOIL OR AREA OF SPILL FROM THE SITE IN ACCORDANCE WITH BOTH THE MANUFACTURER RECOMMENDATIONS, FEDERAL, STATE, AND LOCAL REQUIREMENTS. DO NOT HOSE DOWN AND SPREAD SPILLED ITEM. ALL CHEMICALS USED ON THE SITE SHALL BE IN LEAK-PROOF CONTAINERS STORED AWAY FROM WETLANDS, SURFACE WATERS, STORMWATER INLETS AND DRAINAGE MEASURES. SPILL KITS SHALL BE AVAILABLE ONSITE FOR EMERGENCY USE. THERE SHALL BE A SECONDARY CONTAINMENT MEASURE OF ALL CHEMICALS IN ADDITION TO SPILL-PROOF CONTAINERS.
31. PRIOR TO COMMENCEMENT OF CONSTRUCTION, APPLICABLE CONTRACTOR PERSONNEL MUST HAVE AN UNDERSTANDING OF THE EPA CONSTRUCTION GENERAL PERMIT REQUIREMENTS AND THEIR SPECIFIC RESPONSIBILITIES UNDER THE PERMIT. AT A MINIMUM, PERSONNEL MUST BE TRAINED AND UNDERSTAND THE FOLLOWING: LOCATION OF ALL STORMWATER CONTROLS AND HOW TO MAINTAIN THEM, PROCEDURES FOR COMPLYING WITH THE POLLUTION PREVENTION REQUIREMENTS, PROCEDURES FOR CONDUCTING INSPECTIONS, RECORDING FINDINGS, AND TAKING CORRECTIVE ACTION.
32. ALL SEDIMENT TRACKED ONTO ROADWAYS MUST BE REMOVED AT END OF EACH WORK DAY.
33. ALL USE OF CATIONIC TREATMENT CHEMICALS (EXAMPLES INCLUDE POLYMERS, CHITOSAN, CATIONIC PAM, FLOCCULANTS OR OTHER CHEMICAL UTILIZED FOR STABILIZATION) ARE PROHIBITED. IF ALL OTHER AVAILABLE STABILIZATION MEASURES ARE NOT POSSIBLE AND USE OF CATIONIC CHEMICALS IS ABSOLUTELY NECESSARY THE CONTRACTOR WILL NEED TO CONTACT THE EPA NEW ENGLAND OFFICE IN WRITING FOR APPROVAL AND SPECIFIC REQUIREMENTS (MAXIMUM DOSAGE RATE, RESIDUAL TESTING, SPECIFIC LIMITATIONS, ETC) PRIOR TO USE.
34. IF USING NON-VEGETATIVE STABILIZATION MEASURES, IT MUST BE COMPLETED NO LATER THAN 14 DAYS AFTER INITIATING STABILIZATION. ALL AREAS OF EXPOSED SOILS MUST BE COVERED.
35. INSPECTIONS OF EROSION CONTROL MEASURES SHALL BE AT LEAST ONCE EVERY 7 DAYS BY THE CONTRACTOR. AT A MINIMUM INSPECTIONS SHALL INCLUDE ALL DISTURBED AREAS, ALL STORMWATER CONTROLS AND POLLUTION MEASURES. ALL LOCATIONS WHERE STABILIZATION MEASURES HAVE BEEN IMPLEMENTED, EQUIPMENT AND MATERIAL STORAGE AREAS, ALL AREAS WHERE STORMWATER FLOWS AND ALL POINTS OF DISCHARGE. WHEN CORRECTIVE ACTIONS ARE REQUIRED, THE CONTRACTOR MUST IMMEDIATELY TAKE ALL STEPS TO PREVENT POLLUTANT DISCHARGES UNTIL A PERMANENT SOLUTION IS IMPLEMENTED. AS NECESSARY NEW OR MODIFIED CONTROLS MUST BE INSTALLED AND OPERATIONAL. THE REPAIR MUST BE COMPLETED WITHIN 7 DAYS FROM THE TIME OF DISCOVERY. WITHIN 24 HOURS OF A TRIGGERING CONDITION OCCURRING THAT REQUIRES A CORRECTIVE ACTION, A CORRECTIVE ACTION REPORT MUST BE COMPLETED.

## MAINTENANCE:

- ALL MEASURES STATED ON THE STORMWATER POLLUTION PREVENTION PLANS, SHALL BE MAINTAINED IN FULLY FUNCTIONAL CONDITION BY CONTRACTOR UNTIL NO LONGER REQUIRED FOR A COMPLETED PHASE OF WORK OR FINAL STABILIZATION OF THE SITE. ALL EROSION AND SEDIMENTATION CONTROL MEASURES SHALL BE CHECKED BY A QUALIFIED PERSON IN ACCORDANCE WITH THE CONTRACT DOCUMENTS OR THE APPLICABLE PERMIT, WHICHEVER IS MORE STRINGENT, AND REPAIRED IN ACCORDANCE WITH THE FOLLOWING:
1. INLET PROTECTION DEVICES AND BARRIERS SHALL BE REPAIRED OR REPLACED IF THEY SHOW SIGNS OF UNDERMINING, OR DETERIORATION.
  2. ALL SEEDED AREAS SHALL BE CHECKED REGULARLY TO SEE THAT A HEALTHY STAND OF GRASS IS MAINTAINED. AREAS SHOULD BE FERTILIZED, WATERED, AND RESEEDED AS NEEDED.
  3. ALL SEDIMENT CONTROLS SHALL BE REPAIRED TO THEIR ORIGINAL CONDITIONS IF DAMAGED. SEDIMENT SHALL BE REMOVED FROM THE TUBULAR SEDIMENT CONTROLS WHEN IT REACHES HALF THE HEIGHT OF THE CONTROL MEASURE OR AS REQUESTED BY THE OWNER OR ENGINEER.
  4. THE CONSTRUCTION ENTRANCES SHALL BE MAINTAINED IN A CONDITION WHICH WILL PREVENT TRACKING OR FLOW OF MUD ONTO PUBLIC RIGHTS-OF-WAY. THIS MAY REQUIRE PERIODIC TOP DRESSING OF THE CONSTRUCTION ENTRANCES AS CONDITIONS DEMAND.
  5. THE TEMPORARY PARKING AND STORAGE AREA SHALL BE KEPT IN GOOD CONDITION (SUITABLE FOR PARKING AND STORAGE). THIS MAY REQUIRE PERIODIC TOP DRESSING OF THE TEMPORARY PARKING AS CONDITIONS DEMAND.
  6. OUTLET STRUCTURES IN THE SEDIMENTATION BASINS SHALL BE MAINTAINED IN OPERATIONAL CONDITIONS AT ALL TIMES. SEDIMENT SHALL BE REMOVED FROM SEDIMENT BASINS OR TRAPS WHEN THE DESIGN CAPACITY HAS BEEN REDUCED BY 50%.

## CONSTRUCTION GENERAL PERMIT NOTES AND NARRATIVE:

NARRATIVE: THE STORMWATER POLLUTION PREVENTION PLANS CONSIST OF THE SITE PREPARATION PLAN TOGETHER WITH AN EXISTING CONDITIONS PLANS, GRADING PLANS, ABBREVIATIONS AND NOTES SHEETS, AND DETAIL SHEETS.

THE EROSION CONTROL PLAN WILL BE IMPLEMENTED TO:

- A. TREAT EROSION AS SOON AS POSSIBLE AFTER DISTURBANCE.
- B. PREVENT SEDIMENT FROM LEAVING THE CONSTRUCTION AREA AND ENTERING THE RECEIVING WATERS.
- C. CONSTRUCTION ACTIVITIES SHALL BE SCHEDULED TO MINIMIZE EROSION.
- D. ONLY DISTURB, CLEAR, OR GRADE AREAS NECESSARY FOR CONSTRUCTION.

R:\PROJECTS\2712-02A\CIVIL\DRAWINGS\CURRENT\C-2712-02A-SITE-PRP.DWG



PROFESSIONAL ENGINEER FOR ALLEN & MAJOR ASSOCIATES, INC.

REV	DATE	DESCRIPTION
1	04-04-23	REVISION 1 PER PEER REVIEW

APPLICANT/OWNER:  
**TMC HOLDINGS & DEVELOPMENT 2, LLC**  
 24 WILLIAM WAY  
 BELLINGHAM, MA 02019

PROJECT:  
**25 FORGE PARKWAY**  
 FRANKLIN, MA

PROJECT NO.	2712-02A	DATE:	02-21-23
SCALE:	NONE	DWG. NAME:	C-2712-02A
DESIGNED BY:	SM/JRG	CHECKED BY:	BDJ

PREPARED BY:

**ALLEN & MAJOR ASSOCIATES, INC.**  
 civil engineering • land surveying  
 environmental consulting • landscape architecture  
 www.allenmajor.com  
 100 COMMERCE WAY, SUITE 5  
 WOBURN MA 01801  
 TEL: (781) 935-6889  
 FAX: (781) 935-2896  
 WOBURN, MA • LAKEVILLE, MA • MANCHESTER, NH

THIS DRAWING HAS BEEN PREPARED IN DIGITAL FORMAT. CLIENT/CUSTOMER REPRESENTATIVE OR CONSULTANT MAY BE PROVIDED COPIES OF DRAWINGS AND SPECIFICATIONS FOR HIS/HER INFORMATION AND/OR SPECIFIC USE ON THIS PROJECT. DUE TO THE POTENTIAL THAT THE PROVIDED INFORMATION MAY BE MODIFIED UNINTENTIONALLY OR OTHERWISE, ALLEN & MAJOR ASSOCIATES, INC. MAY REMOVE ALL INDICATION OF THE DOCUMENT'S AUTHORSHIP ON THE DIGITAL MEDIA. PRINTED REPRESENTATIONS OR PORTABLE DOCUMENT FORMAT OF THE DRAWINGS AND SPECIFICATIONS ISSUED SHALL BE THE ONLY RECORD COPIES OF ALLEN & MAJOR ASSOCIATES, INC.'S WORK PRODUCT.

DRAWING TITLE: <b>EROSION CONTROL &amp; SITE PREPARATION NOTES</b>	SHEET No. <b>C-001</b>
---	---------------------------

Copyright © 2023 Allen & Major Associates, Inc. All Rights Reserved.



**GENERAL SEQUENCE OF CONSTRUCTION:**

- CONTACT THE TOWN ENGINEERING DEPARTMENT AT LEAST TWO (2) WEEKS PRIOR TO START OF CONSTRUCTION. GROUND-BREAKING IS EXPECTED TO BEGIN ON JUNE 1, 2023 AND THE PROJECT IS ANTICIPATED TO TAKE 12 MONTHS UNTIL COMPLETION.
- INSTALL STABILIZED CONSTRUCTION ENTRANCES. SITE ACCESS SHALL BE ACHIEVED ONLY FROM THE DESIGNATED CONSTRUCTION ENTRANCE.
- PREPARE TEMPORARY PARKING AND STORAGE AREA UPON IMPLEMENTATION AND INSTALLATION OF THE FOLLOWING AREAS: TRAILER, PARKING, LAY DOWN, WHEEL WASH, CONCRETE WASHOUT, MASON'S AREA, FUEL AND MATERIAL STORAGE CONTAINERS, SOLID WASTE CONTAINERS, ETC. DENOTE THEM ON THE SITE MAPS IMMEDIATELY AND NOTE ANY CHANGES IN THE LOCATIONS AS THEY OCCUR THROUGHOUT THE CONSTRUCTION PROCESS.
- INSTALL THE TUBULAR BARRIERS AND SILT SACKS AS SHOWN HEREON. EROSION CONTROL BARRIERS MUST BE INSPECTED AND APPROVED BY A PROFESSIONAL ENGINEER OR LICENSED WETLANDS SCIENTIST. NO SEDIMENTATION BARRIER MAY BE REMOVED WITHOUT PRIOR APPROVAL OF THE COMMISSION OR ITS STAFF.
- CLEAR AND GRUB THE SITE.
- CONSTRUCT TEMPORARY SEDIMENTATION AND SEDIMENT TRAP BASINS AS NECESSARY.
- CONSTRUCT STORMWATER MEASURES. SITE SHALL BE STABILIZED PRIOR TO STORMWATER MEASURES RECEIVING RUNOFF.
- START CONSTRUCTION OF BUILDING PAD AND STRUCTURES. TEMPORARILY SEED DENUDED AREAS. ALL CUT AND FILL SLOPES SHALL BE SEED / LOAMED WITHIN 72 HOURS OF ACHIEVING FINISH GRADE, EXCEPT WHERE RIP RAP IS APPLIED.
- INSTALL BUILDING, UTILITIES, STORM SEWERS, CURBS AND GUTTERS.
- INSTALL INLET PROTECTION DEVICES AROUND ALL STORM DRAIN STRUCTURES.
- INSTALL RIP RAP AROUND OUTLET STRUCTURES.
- FINALIZE GRADING, AND PREPARE SITE FOR PAVING. NOTE, ALL PARKING LOTS SHALL BE STABILIZED WITHIN 72 HOURS OF ACHIEVING FINISH GRADE.
- PAVE SITE, COMPLETE FINISH GRADING AND INSTALL PERMANENT SEEDING AND PLANTING.
- ONCE SITE IS STABILIZED, REMOVE ALL TEMPORARY EROSION AND SEDIMENT CONTROL DEVICES.
- ALL EROSION CONTROL MEASURES SHALL BE INSPECTED WEEKLY AND AFTER ALL RAINFALL EVENTS GREATER THAN 0.25", AND SHALL BE MAINTAINED, REPAIRED OR REPLACED AS REQUIRED OR AT THE DIRECTION OF THE OWNER'S ENGINEER, OR THE TOWN ENGINEER.

- SEDIMENT ACCUMULATION UP-GRADIENT OF THE TUBULAR BARRIERS GREATER THAN 6" IN DEPTH SHALL BE REMOVED AND DISPOSED OF IN ACCORDANCE WITH ALL APPLICABLE REGULATIONS.
- IF IT APPEARS THAT SEDIMENT IS EXITING THE SITE, SILT SACKS SHALL BE INSTALLED IN ALL CATCH BASINS ADJACENT TO THE SITE. SEDIMENT ACCUMULATION ON ALL ADJACENT CATCH BASIN INLETS SHALL BE REMOVED AND THE SILT SACK REPLACED IF TORN OR DAMAGED.
- THE CONTRACTOR SHALL COMPLY WITH THE GENERAL AND EROSION NOTES AS SHOWN ON THE SITE DEVELOPMENT PLANS, SEE ALSO SHEET C-001.

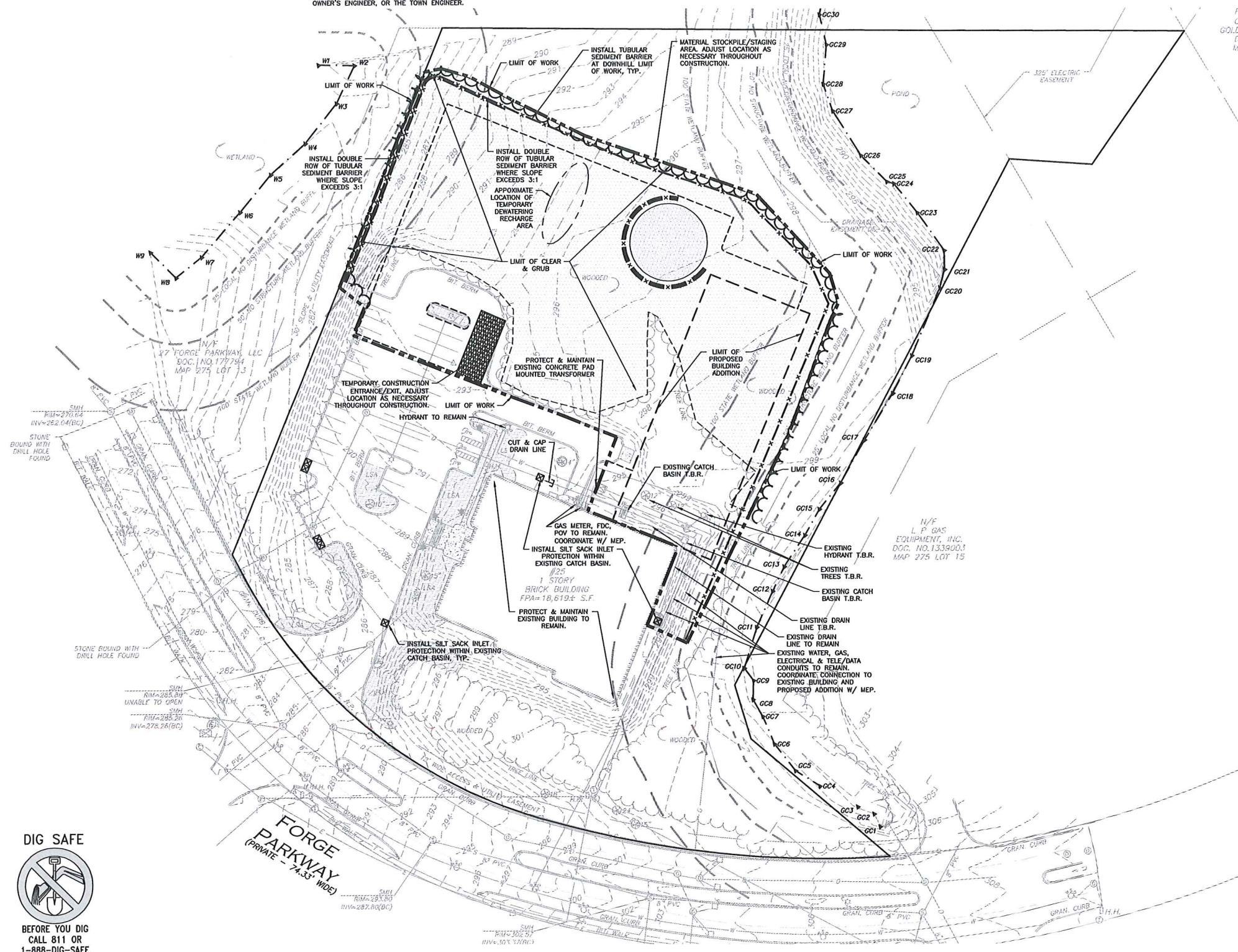

**LEGEND**

- LIMIT OF DISTURBANCE: [Symbol]
- LIMIT OF 'CLEAR AND GRUB': [Symbol]
- STABILIZED ENTRANCE: [Symbol]
- STOCKPILE/STAGING AREA: [Symbol]
- TUBULAR BARRIER: [Symbol]
- UTILITY CUT AND CAP: [Symbol]
- CATCH BASIN FILTER: [Symbol]

**NOTES:**

- THE CONTRACTOR IS SPECIFICALLY CAUTIONED THAT THE LOCATION AND/OR ELEVATION OF EXISTING UTILITIES AND STRUCTURES AS SHOWN ON THESE PLANS IS BASED ON RECORDS OF VARIOUS UTILITY COMPANIES AND WHERE POSSIBLE, MEASUREMENTS TAKEN IN THE FIELD. THIS INFORMATION IS NOT TO BE RELIED ON AS BEING EXACT OR COMPLETE. THE LOCATION OF ALL UNDERGROUND UTILITIES AND STRUCTURES SHALL BE VERIFIED IN THE FIELD BY THE CONTRACTOR PRIOR TO THE START OF CONSTRUCTION.
- THE CONTRACTOR SHALL DETERMINE THE EXACT LOCATION OF ALL EXISTING UTILITIES BEFORE COMMENCING WORK, AND AGREES TO BE FULLY RESPONSIBLE FOR ANY AND ALL DAMAGES WHICH MIGHT BE OCCASIONED BY THE CONTRACTOR'S FAILURE TO EXACTLY LOCATE AND PRESERVE ANY AND ALL UNDERGROUND UTILITIES.
- THE CONTRACTOR MUST CONTACT THE APPROPRIATE UTILITY COMPANY, ANY GOVERNING PERMITTING AUTHORITY, AND "DIGSAFE" AT LEAST 72 HOURS PRIOR TO ANY EXCAVATION WORK TO REQUEST EXACT FIELD LOCATION OF UTILITIES. THE ENGINEER SHALL BE NOTIFIED IN WRITING OF ANY UTILITIES INTERFERING WITH THE PROPOSED CONSTRUCTION AND APPROPRIATE REMEDIAL ACTION TAKEN BEFORE PROCEEDING WITH THE WORK. IT SHALL BE THE RESPONSIBILITY OF THE CONTRACTOR TO RELOCATE ALL EXISTING UTILITIES WHICH CONFLICT WITH THE PROPOSED IMPROVEMENTS SHOWN ON THE PLANS.
- ALTHOUGH CERTAIN ITEMS HAVE BEEN NOTED ON THIS DRAWING FOR DEMOLITION, NO ATTEMPT HAS BEEN MADE TO DELINEATE EACH AND EVERY ITEM THAT REQUIRES DEMOLITION FOR THE COMPLETION OF THE PROJECT. THE CONTRACTOR WILL BE RESPONSIBLE FOR ALL NECESSARY DEMOLITION WORK TO COMPLETE THE PROJECT. ALLEN & MAJOR ASSOCIATES, INC. IS NOT RESPONSIBLE FOR SITE DEMOLITION ITEMS NOT SHOWN ON THE SURVEY, OR SPECIFICALLY NOTED. THE DEMOLITION NOTES AND ARROWS ON THIS PLAN ARE TYPICAL AND DO NOT REFLECT QUANTITY.
- THE ENGINEER SHALL BE NOTIFIED IN WRITING OF ANY UTILITIES INTERFERING WITH THE PROPOSED CONSTRUCTION AND APPROPRIATE REMEDIAL ACTION TAKEN BEFORE PROCEEDING WITH THE WORK. IT SHALL BE THE RESPONSIBILITY OF THE CONTRACTOR TO RELOCATE ALL EXISTING UTILITIES WHICH CONFLICT WITH THE PROPOSED IMPROVEMENTS SHOWN ON THE PLAN.
- EROSION CONTROL MEASURES SHALL BE INSTALLED PRIOR TO THE START OF CONSTRUCTION. IF IT ADDITIONAL MEASURES ARE NECESSARY DURING CONSTRUCTION THEY SHALL BE INSTALLED IMMEDIATELY AND WITHOUT DELAY. SEE DETAIL SHEET C-501 FOR ADDITIONAL INFORMATION.
- INLET PROTECTION SHALL BE INSTALLED IN PROPOSED CATCH BASINS IMMEDIATELY UPON CONSTRUCTION.
- THE INFORMATION SHOWN ON THIS PLAN IS THE SOLE PROPERTY OF ALLEN & MAJOR ASSOCIATES, INC. ITS INTENDED USE IS TO PROVIDE INFORMATION. ANY ALTERATION, MISUSE, OR RECALCULATION OF INFORMATION OR DATA WITHOUT THE EXPRESSED, WRITTEN CONSENT OF ALLEN & MAJOR ASSOCIATES, INC. IS STRICTLY PROHIBITED.

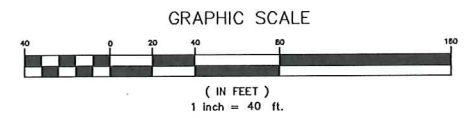

Professional Engineer Seal for Brian D. Jones, No. 49212, State of Massachusetts. Signature and date 04-04-23.

REV	DATE	DESCRIPTION
1	04-04-23	REVISION 1 PER PEER REVIEW

APPLICANT/OWNER:  
**TMC HOLDINGS & DEVELOPMENT 2, LLC**  
 24 WILLIAM WAY  
 BELLINGHAM, MA 02019

PROJECT:  
**25 FORGE PARKWAY**  
 FRANKLIN, MA

PROJECT NO.	2712-02A	DATE:	02-21-23
SCALE:	1" = 40'	DWG. NAME:	C2712-02A
DESIGNED BY:	SM/JRG	CHECKED BY:	BDJ

**ALLEN & MAJOR ASSOCIATES, INC.**  
 civil engineering • land surveying  
 environmental consulting • landscape architecture  
 www.allenmajor.com  
 100 COMMERCE WAY, SUITE 5  
 WOBURN, MA 01801  
 TEL: (781) 935-6889  
 FAX: (781) 935-2896

WOBURN, MA • LAKEVILLE, MA • MANCHESTER, NH

THIS DRAWING HAS BEEN PREPARED IN DIGITAL FORMAT. CLIENTS REPRESENTATIVE OR CONSULTANTS MAY BE PROVIDED COPIES OF DRAWINGS AND SPECIFICATIONS FOR HIS/HER INFORMATION AND/OR SPECIFIC USE ON THIS PROJECT. DUE TO THE POTENTIAL THAT THE PROVIDED INFORMATION MAY BE MODIFIED UNINTENTIONALLY OR OTHERWISE, ALLEN & MAJOR ASSOCIATES, INC. MAY REMOVE ALL INDICATION OF THE DOCUMENT'S AUTHORSHIP ON THE DIGITAL MEDIA. PRINTED REPRESENTATIONS OR PORTABLE DOCUMENT FORMAT OF THE DRAWINGS AND SPECIFICATIONS ISSUED SHALL BE THE ONLY RECORD COPIES OF ALLEN & MAJOR ASSOCIATES, INC.'S WORK PRODUCT.

DRAWING TITLE:	SHEET No.
<b>SITE PREPARATION PLAN</b>	<b>C-101</b>

Copyright © 2023 Allen & Major Associates, Inc. All Rights Reserved.

R:\PROJECTS\2712-02A\CIVIL\DRAWINGS\CURRENT\C-2712-02A-SITE-PREP.DWG

**DIG SAFE**

BEFORE YOU DIG  
 CALL 811 OR  
 1-888-DIG-SAFE  
 1-888-344-7233



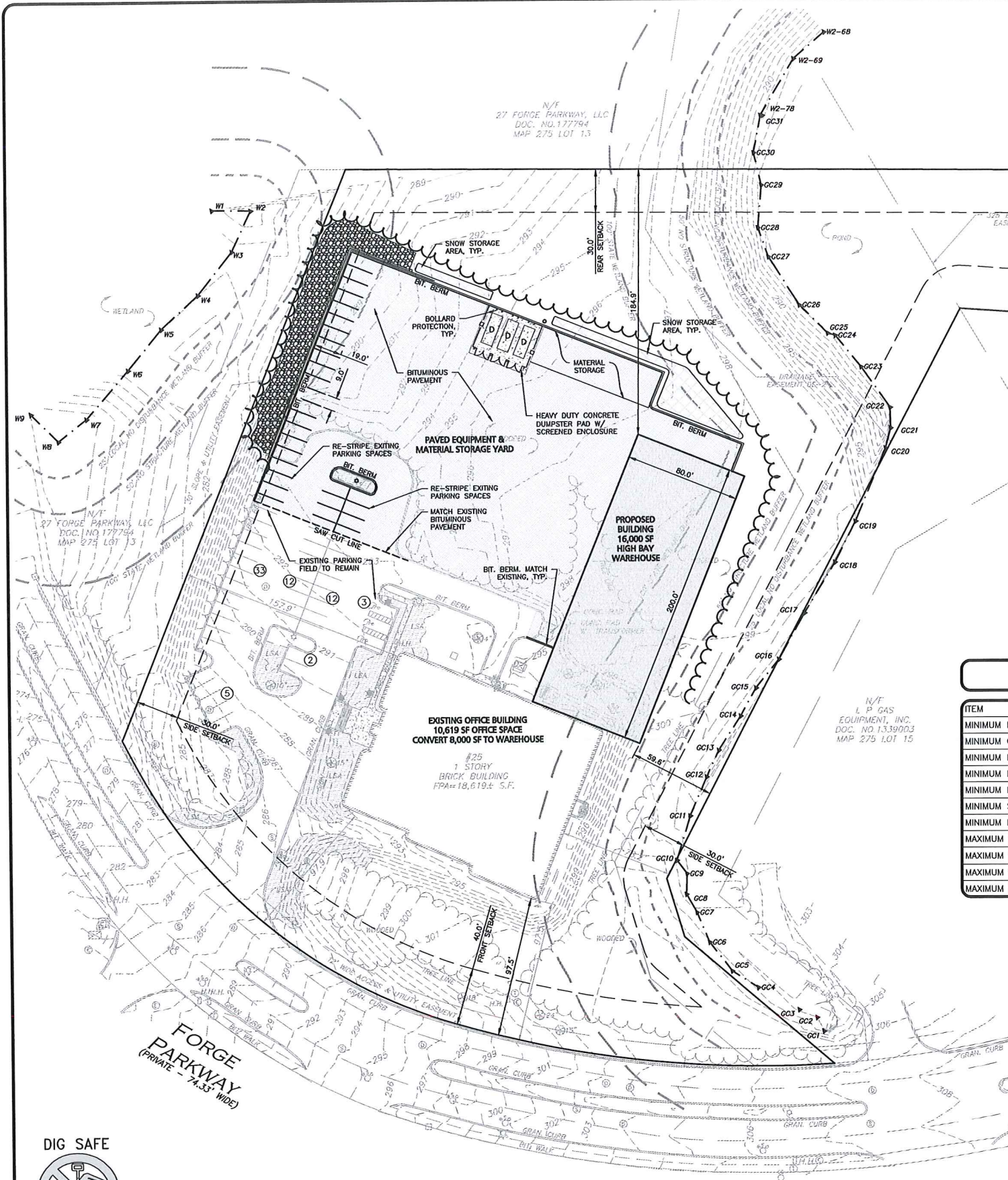

N/E  
NEW ENGLAND  
TREATMENT ACCESS  
REV. 3/6/14/7/PG. 5/26  
MAP 275 LOT 19

N/E  
FORGE PARKWAY  
OWNER LLC, C/O  
GOLDMAN SACHS & CO.  
DOC. NO. 197713  
MAP 275 LOT 17

N/E  
27 FORGE PARKWAY, LLC  
DOC. NO. 177794  
MAP 275 LOT 13

**DIG SAFE**  
BEFORE YOU DIG  
CALL 811 OR  
1-888-DIG-SAFE  
1-888-344-7233

OFF-STREET PARKING AND LOADING SUMMARY TABLE	
USE: EXISTING OFFICE BUILDING: 10,619 SF	REQUIRED
1 SPACE PER 250 SQUARE FEET	42 PARKING SPACES
10,619 SF / 250 = 42 SPACES	
USE: WAREHOUSE: 24,000 SQUARE FEET (16,000 + 8,000 FROM EX. BLDG.)	REQUIRED
1 SPACE REQUIRED PER 1,000 SQUARE FEET	24 PARKING SPACES
24,000 SF / 1,000 = 24 SPACES	
<b>TOTAL REQUIRED PARKING = 66 PARKING SPACES</b>	
ACCESSIBLE PARKING SPACE REQUIREMENT: FOR 51 TO 75 SPACES, 3 SHALL BE ACCESSIBLE, 1 SHALL BE VAN ACCESSIBLE)	
	3 ADA SPACES
<b>TOTAL PARKING PROVIDED: 67 PARKING SPACES</b>	
STANDARD	ACCESSIBLE
64	3

TABLE NOTES:  
1. PROPOSED PARKING SPACES SHALL BE A MINIMUM OF 9 FEET IN WIDTH AND 19 FEET IN DEPTH FOR 90° PARKING.

**TOWN OF FRANKLIN INDUSTRIAL (I) DISTRICT**

ITEM	REQUIRED	EXISTING	PROPOSED
MINIMUM LOT AREA	40,000 SF	257,365 SF	257,365 SF
MINIMUM CONTINUOUS FRONTAGE	175 FEET	582 FEET	582 FEET
MINIMUM LOT DEPTH	200 FEET	619 FEET	619 FEET
MINIMUM LOT WIDTH	157.5 FEET	196 FEET	196 FEET
MINIMUM FRONT SETBACK	40 FEET	97.5 FEET	97.5 FEET
MINIMUM SIDE SETBACK	30 FEET	78.2 FEET	59.6 FEET
MINIMUM REAR SETBACK	30 FEET	336.7 FEET	184.9 FEET
MAXIMUM BUILDING STORIES	3	1	1
MAXIMUM BUILDING HEIGHT	N/A	20± FEET	28 FEET
MAXIMUM STRUCTURE COVERAGE	70%	7.23%	13.5%
MAXIMUM IMPERVIOUS COVERAGE	80%	18.5%	39.2%

**LEGEND**

- PROPERTY LINE
- BOLLARD
- BUILDING
- CURB
- PARKING STRIPING
- HEAVY DUTY CONCRETE
- BITUMINOUS PAVEMENT
- SNOW STORAGE
- STEEL GUARDRAIL
- WOOD FENCE
- SETBACK LINE
- SAW-CUT LINE
- PARKING COUNT
- RIPRAP
- TREE LINE

- NOTES:**
- ALL CURB RADII SHALL BE 3' UNLESS OTHERWISE NOTED.
  - PARKING DIMENSIONS ARE TAKEN FROM THE FACE OF CURB UNLESS OTHERWISE NOTED.
  - CONSTRUCTION DURING WET WEATHER OR WINTER CONDITIONS IS TO BE ANTICIPATED AND PROVISIONS TO ADEQUATELY ADDRESS THESE CONDITIONS SHALL BE THE RESPONSIBILITY OF THE CONTRACTOR.
  - ALL CONSTRUCTION SHALL CONFORM TO THE APPLICABLE REGULATIONS AND STANDARDS INCLUDING THE TOWN OF FRANKLIN, MADOT, MADEP, MUTCD, AND AASHTO.
  - WRITTEN DIMENSIONS ON THIS PLAN TAKE PRECEDENCE OVER SCALED DIMENSIONS. THE CONTRACTOR SHALL USE CAUTION WHEN SCALING REPRODUCED PLANS. IN THE EVENT OF A CONFLICT BETWEEN THIS PLAN SET AND ANY OTHER DRAWINGS AND/OR SPECIFICATIONS OR CONDITIONS, THE ENGINEER SHALL BE NOTIFIED BY THE CONTRACTOR. ALL SITE ITEMS SHALL BE LAID OUT AND AS BUILT BY A LICENSED LAND SURVEYOR.
  - EXISTING CONDITIONS WERE COMPILED FROM AN ON THE GROUND SURVEY PERFORMED BY ALLEN & MAJOR ASSOCIATES, INC. AS WELL AS AVAILABLE RECORD PLANS OBTAINED FROM THE TOWN OF FRANKLIN, MA AND OTHER SOURCES.
  - THE CONTRACTOR MUST CONTACT THE APPROPRIATE UTILITY COMPANY, ANY GOVERNING PERMITTING AUTHORITY, AND "DIGSAFE" AT LEAST 72 HOURS PRIOR TO ANY EXCAVATION WORK. THE CONTRACTOR SHALL ALSO CONTACT THE TOWN OF FRANKLIN, MA DEPARTMENT OF PUBLIC WORKS AT LEAST 72 HOURS PRIOR TO ANY EXCAVATION WORK TO REQUEST EXACT FIELD LOCATION OF LOCAL UTILITIES.
  - THE INFORMATION SHOWN ON THIS PLAN IS THE SOLE PROPERTY OF ALLEN & MAJOR ASSOCIATES, INC. ANY ALTERATION, MISUSE, OR RECALCULATION OF INFORMATION OR DATA WITHOUT THE EXPRESSED, WRITTEN CONSENT OF ALLEN & MAJOR ASSOCIATES, INC. IS STRICTLY PROHIBITED.
  - FLOOR DRAINS IN THE PROPOSED BUILDING ADDITION SHALL FLOW THROUGH A GAS TRAP PRIOR TO DISCHARGE TO THE MUNICIPAL SANITARY SYSTEM.

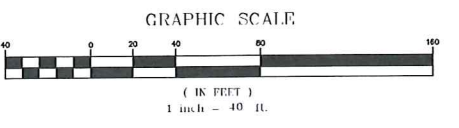

PROFESSIONAL ENGINEER FOR ALLEN & MAJOR ASSOCIATES, INC.

REV	DATE	DESCRIPTION
1	04-04-23	REVISION 1 PER PEER REVIEW

APPLICANT/OWNER:  
**TMC HOLDINGS & DEVELOPMENT 2, LLC**  
24 WILLIAM WAY  
BELLINGHAM, MA 02019

**PROJECT:**  
25 FORGE PARKWAY  
FRANKLIN, MA

PROJECT NO. 2712-02A DATE: 02-21-23  
SCALE: 1" = 40' DWG. NAME: C-2712-02A  
DESIGNED BY: SM/JRG CHECKED BY: BDI

PREPARED BY:

**ALLEN & MAJOR ASSOCIATES, INC.**  
civil engineering • land surveying  
environmental consulting • landscape architecture  
www.allenmajor.com  
100 COMMERCE WAY, SUITE 3  
WOBURN, MA 01801  
TEL: (781) 935-6889  
FAX: (781) 935-2896

WOBURN, MA • LAKEVILLE, MA • MANCHESTER, NH  
THIS DRAWING HAS BEEN PREPARED IN DIGITAL FORMAT. CLIENTS/CLIENTS REPRESENTATIVE OR CONSULTANTS MAY BE PROVIDED COPIES OF DRAWINGS AND SPECIFICATIONS FOR HIS/HER INFORMATION AND/OR SPECIFIC USE ON THIS PROJECT. DUE TO THE POTENTIAL THAT THE PROVIDED INFORMATION MAY BE MODIFIED UNINTENTIONALLY OR OTHERWISE, ALLEN & MAJOR ASSOCIATES, INC. MAY REMOVE ALL INDICATION OF THE DOCUMENT'S AUTHORSHIP ON THE DIGITAL MEDIA. PRINTED REPRESENTATIONS OR PORTABLE DOCUMENT FORMAT OF THE DRAWINGS AND SPECIFICATIONS ISSUED SHALL BE THE ONLY RECORD COPIES OF ALLEN & MAJOR ASSOCIATES, INC.'S WORK PRODUCT.

DRAWING TITLE: **LAYOUT & MATERIALS PLAN** SHEET No. **C-102**



**INFILTRATION SYSTEM PROTECTION NOTES**

- DO NOT TRAFFIC EXPOSED SOIL SURFACE WITH CONSTRUCTION EQUIPMENT. IF FEASIBLE, PERFORM EXCAVATIONS WITH EQUIPMENT POSITIONED OUTSIDE THE LIMITS OF THE INFILTRATION SYSTEM.
- AFTER THE INFILTRATION SYSTEM AREA IS EXCAVATED TO THE FINAL DESIGN ELEVATION, THE FLOOR SHOULD BE DEEPLY TILLED WITH A ROTARY TILLER OR DISC HARROW TO RESTORE INFILTRATION RATES, FOLLOWED BY A PASS WITH A LEVELING DRAG.
- DO NOT PLACE INFILTRATION SYSTEMS INTO SERVICE UNTIL THE CONTRIBUTING AREAS HAVE BEEN FULLY STABILIZED.

**LEGEND**

- DRAIN MANHOLE
- CATCH BASIN
- CATCH BASIN - DOUBLE GRATE
- OUTLET CONTROL
- HEADWALL
- DRAIN LINE
- RIPRAP
- 5' CONTOUR
- 1' CONTOUR
- SPOT GRADE
- INFILTRATION SYSTEM
- INFILTRATION CHAMBER
- ISOLATOR ROW
- FLOW DIRECTION



PROFESSIONAL ENGINEER FOR ALLEN & MAJOR ASSOCIATES, INC.

**NOTES:**

- EXISTING CONDITIONS WERE COMPILED FROM AN ON THE GROUND SURVEY PERFORMED BY ALLEN & MAJOR ASSOCIATES, INC. AS WELL AS AVAILABLE RECORD PLANS OBTAINED FROM THE TOWN OF FRANKLIN, MA AND OTHER SOURCES.
- VERTICAL DATUM IS NAVD88. EXISTING GRADE CONTOUR INTERVALS SHOWN AT 1 FOOT. PROPOSED GRADE CONTOUR INTERVALS SHOWN AT 1 FOOT.
- ALL CUT OR FILL SLOPES SHALL BE 3:1 OR FLATTER UNLESS OTHERWISE NOTED.
- PIPE DIMENSIONS ARE MEASURED FROM THE CENTER OF THE STRUCTURE.
- ROOF DRAIN LOCATIONS TO BE BASED ON FINAL BUILDING PLANS. CONNECTION POINTS SHALL BE AS SHOWN HEREON.
- IF ANY EXISTING STRUCTURES TO REMAIN ARE DAMAGED DURING CONSTRUCTION IT SHALL BE THE CONTRACTOR'S RESPONSIBILITY TO REPAIR AND/OR REPLACE THE EXISTING STRUCTURE AS NECESSARY TO RETURN IT TO EXISTING CONDITIONS OR BETTER.
- ALL STORM DRAIN MANHOLES IN PAVED AREAS SHALL BE FLUSH WITH PAVEMENT AND SHALL HAVE TRAFFIC BEARING RING & COVERS, H=20 MINIMUM.
- THE CONTRACTOR SHALL ADHERE TO ALL TERMS & CONDITIONS AS OUTLINED IN THE GENERAL N.P.D.E.S. PERMIT FOR STORMWATER DISCHARGE ASSOCIATED WITH CONSTRUCTION ACTIVITIES.
- CONTRACTOR SHALL ADJUST AND/OR CUT EXISTING PAVEMENT AS NECESSARY TO ENSURE A SMOOTH FIT AND CONTINUOUS GRADE.
- CONTRACTOR SHALL ENSURE POSITIVE DRAINAGE AWAY FROM BUILDINGS FOR ALL NATURAL AND PAVED AREAS.
- ALL DRAINAGE SHALL CONFORM TO LOCAL REQUIREMENTS.
- THE INFORMATION SHOWN ON THIS PLAN IS THE SOLE PROPERTY OF ALLEN & MAJOR ASSOCIATES, INC. ANY ALTERATION, MISUSE, OR RECALCULATION OF INFORMATION OR DATA WITHOUT THE EXPRESSED, WRITTEN CONSENT OF ALLEN & MAJOR ASSOCIATES, INC. IS STRICTLY PROHIBITED.
- THE PROJECT RESULTS IN A NET EXPORT OF APPROXIMATELY 3,650 CUBIC YARDS OF MATERIAL. THIS VALUE DOES NOT INCLUDE EXCAVATION REQUIRED FOR BUILDING FOUNDATION, UTILITIES, OR STORMWATER INFRASTRUCTURE.
- PRIOR TO CONSTRUCTION, ONE ADDITIONAL TEST PIT SHALL BE PERFORMED WITHIN THE FOOTPRINT OF THE PROPOSED INFILTRATION SYSTEM TO CONFIRM SEPARATION TO ESTIMATED SEASONAL HIGH GROUND WATER. THE TEST PIT SHALL BE OBSERVED BY THE ENGINEER OF RECORD.

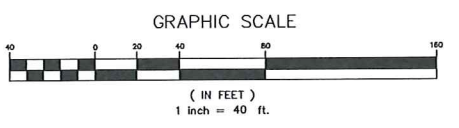

**TEST PIT #1 (TP1)**  
PERFORMED BY: BRIAN D. JONES, PE  
DATE: 02-10-2023

HORIZON	DEPTH	TEXTURE	COLOR	STRUCTURE	NOTES
A	0-8"	LOAMY SAND	10YR 1	MASSIVE, FRIABLE	-
Bw	8-24"	LOAMY SAND	10YR 1	MASSIVE, FRIABLE	-
C	24-66"	LOAMY SAND	2.5Y 1	MASSIVE, FRIABLE	BOULDER AT BOTTOM OF EXCAVATION

ESHW: NONE  
WEEP: NONE  
REFUSAL: NONE

**TEST PIT #2 (TP2)**  
PERFORMED BY: BRIAN D. JONES, PE  
DATE: 02-10-2023

HORIZON	DEPTH	TEXTURE	COLOR	STRUCTURE	NOTES
A	0-8"	LOAMY SAND	10YR 1	MASSIVE, FRIABLE	-
Bw	8-28"	LOAMY SAND	10YR 1	MASSIVE, FRIABLE	-
C	28-108"	LOAMY SAND	2.5Y 1	MASSIVE, FRIABLE	SEVERAL BOULDERS ENCOUNTERED

ESHW: NONE  
WEEP: NONE  
REFUSAL: NONE

**TEST PIT #3 (TP3)**  
PERFORMED BY: BRIAN D. JONES, PE  
DATE: 02-10-2023

HORIZON	DEPTH	TEXTURE	COLOR	STRUCTURE	NOTES
HTM	0-36"	LOAMY SAND	10YR 1	MASSIVE, FRIABLE	-
C1	36-60"	LOAMY SAND	2.5Y 1	MASSIVE, FRIABLE	-
C2	60-100"	SANDY LOAM	10YR 1	MASSIVE, FIRM	-

ESHW: NONE  
WEEP: NONE  
REFUSAL: NONE  
HTM = HUMAN TRANSPORTED MATERIAL

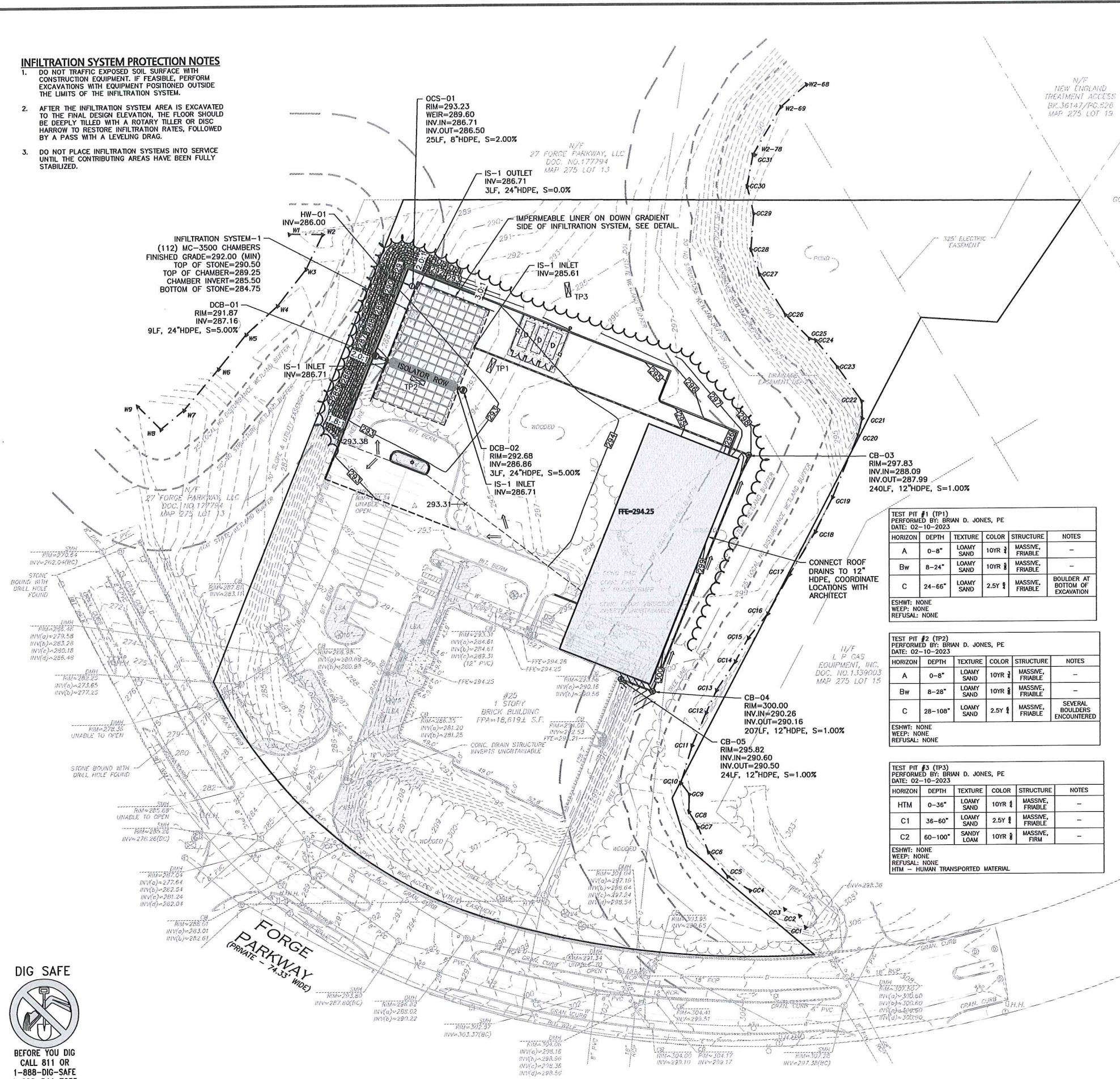

R:\PROJECTS\2712-02A\CIVIL DRAWINGS\CURRENT\C-2712-02A\_GRADING & DRAINAGE.DWG

**APPLICANT/OWNER:**  
TMC HOLDINGS & DEVELOPMENT 2, LLC  
24 WILLIAM WAY  
BELLINGHAM, MA 02019

**PROJECT:**  
25 FORGE PARKWAY  
FRANKLIN, MA

**PROJECT NO.:** 2712-02A **DATE:** 02-21-23

**SCALE:** 1" = 40' **DWG. NAME:** C-2712-02A

**DESIGNED BY:** SM/JRG **CHECKED BY:** BDJ

**PREPARED BY:**

**ALLEN & MAJOR ASSOCIATES, INC.**  
civil engineering • land surveying  
environmental consulting • landscape architecture  
www.allenmajor.com  
100 COMMERCE WAY, SUITE 5  
WOBURN, MA 01801  
TEL: (811) 935-8889  
FAX: (811) 935-8896

WOBURN, MA • LAKEVILLE, MA • MANCHESTER, NH

THIS DRAWING HAS BEEN PREPARED IN DIGITAL FORMAT. CLIENTS REPRESENTATIVE OR CONSULTANTS MAY BE PROVIDED COPIES OF DRAWINGS AND SPECIFICATIONS FOR HIS/HER INFORMATION AND/OR SPECIFIC USE ON THIS PROJECT. DUE TO THE POTENTIAL THAT THE PROVIDED INFORMATION MAY BE MODIFIED UNINTENTIONALLY OR OTHERWISE, ALLEN & MAJOR ASSOCIATES, INC. MAY REMOVE ALL INDICATION OF THE DOCUMENTS AUTHORITY ON THE DIGITAL MEDIA. PRINTED REPRESENTATIONS OR PORTABLE DOCUMENT FORMAT OF THE DRAWINGS AND SPECIFICATIONS ISSUED SHALL BE THE ONLY RECORD COPIES OF ALLEN & MAJOR ASSOCIATES, INC.'S WORK PRODUCT.

**DRAWING TITLE:** GRADING & DRAINAGE PLAN **SHEET No.:** C-103

Copyright © 2023 Allen & Major Associates, Inc. All Rights Reserved.



LUMINAIRE SCHEDULE							
SYMBOL	QTY	LABEL	ARRANGEMENT	HEIGHT	LUMENS	WATTS	DESCRIPTION
W1	7	W1	WALL PACK	25'	5778	46	RWL2-160L-45-3K-4F
W2	1	2SA	DOUBLE, POLE MOUNT	30'	14960	105	TWIN VP-ST-1-36L-105-3K7-4F
W3	1	SA	SINGLE, POLE MOUNT	30'	14960	105	VP-ST-1-36L-105-3L7-4F
W4	1	SB	SINGLE, POLE MOUNT	22'	12189	105	VP-ST-1-36L-39-27K8-4F-UNIV-BC

LIGHTING LEVEL SUMMARY						
AREA	UNITS	AVERAGE	MAX	MIN	AVG/MIN	MAX/MIN
PAVEMENT AREA	Fc	0.26	4.1	0.0	N.A.	N.A.



POLE LIGHT FIXTURE (LED)  
BEACON LIGHTING - VIPER LUMINAIRE



WALL PACK LIGHT FIXTURE (LED)  
HUBBELL LIGHTING INC. - RATIO WALL

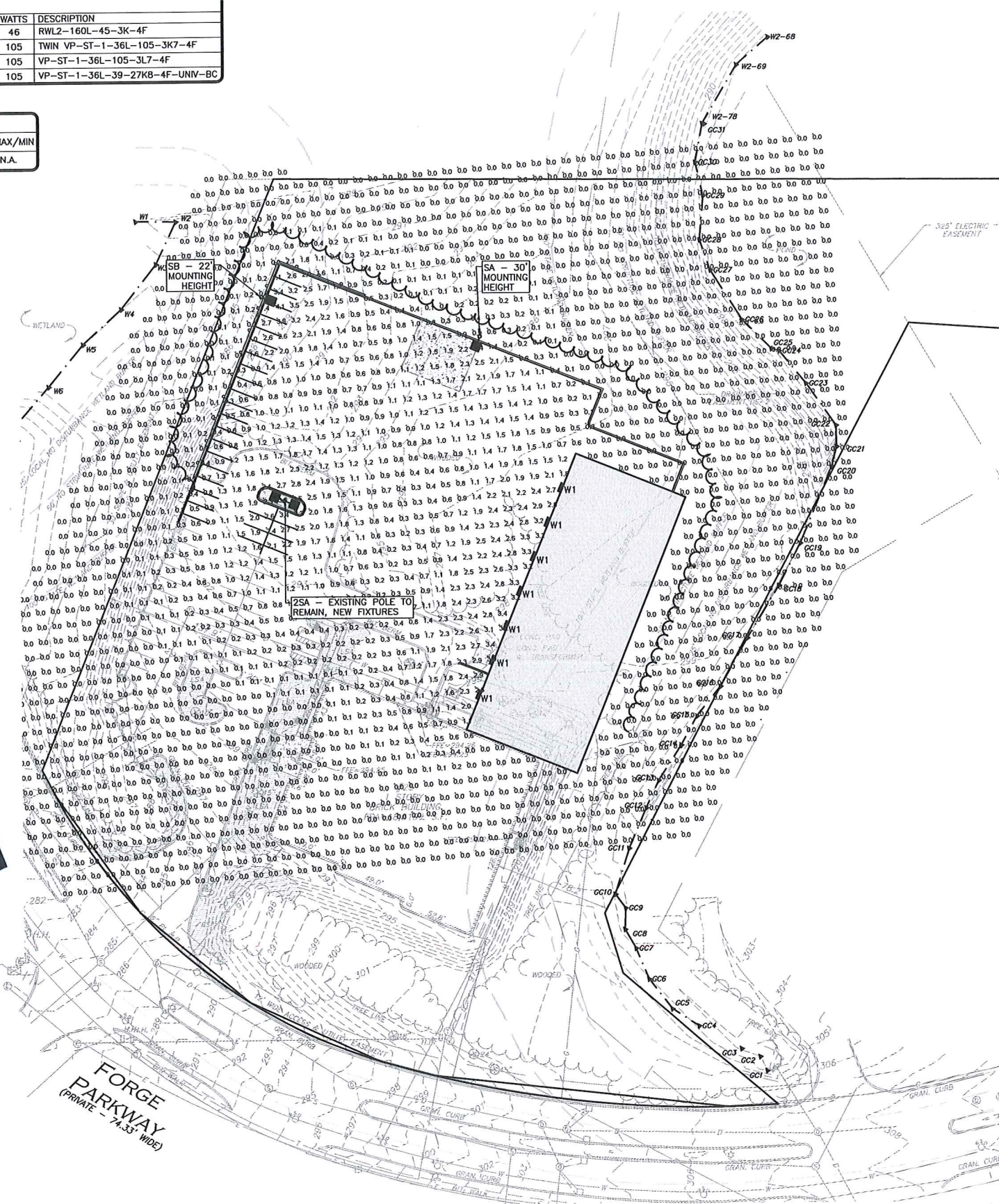

LEGEND	
SINGLE POLE LIGHT	W1
WALL PACK LIGHT	W2
LIGHTING LEVELS GIVEN IN FOOT-CANDLES	0.0 0.1 0.2 0.4 0.6

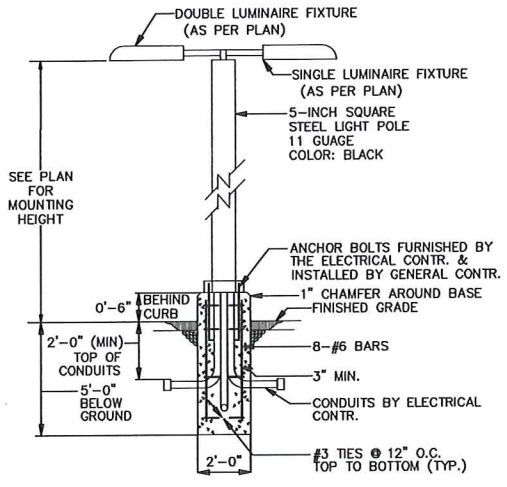

LIGHT POLE & BASE DETAIL  
NOT TO SCALE

- NOTES:**
1. LIGHTING VENDOR CONTACT INFORMATION:  
CHRIS PECHALK  
SWANEY LIGHTING, INC.  
PHONE: 603-380-3400  
E-MAIL: CHRIS@SWANEYLIGHTING.COM
  2. LIGHTS WITHIN THE PARKING AREAS AND ACCESS DRIVES SHALL OPERATE ON A PHOTO-CELL & PROGRAMMABLE TIMER.
  3. CONTROLS FOR ALL EXTERIOR LIGHTING BY BUILDING CONTRACTOR.
  4. WIRING OF BUILDING MOUNTED FIXTURES BY BUILDING CONTRACTOR.
  5. THE INFORMATION SHOWN ON THIS PLAN IS THE SOLE PROPERTY OF ALLEN & MAJOR ASSOCIATES, INC. IT'S INTENDED USE IS TO PROVIDE INFORMATION. ANY ALTERATION, MISUSE, OR RECALCULATION OF INFORMATION OR DATA WITHOUT THE EXPRESSED, WRITTEN CONSENT OF ALLEN & MAJOR ASSOCIATES, INC. IS STRICTLY PROHIBITED.

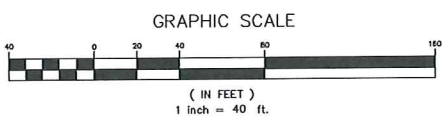

R:\PROJECTS\2712-02A\CIVIL DRAWINGS\CURRENT\C-2712-02A-LIGHTING.DWG

07.04.23  
PROFESSIONAL ENGINEER FOR  
ALLEN & MAJOR ASSOCIATES, INC.

REV	DATE	REVISION 1 PER PEER REVIEW	DESCRIPTION
1	04-04-23		

APPLICANT/OWNER:  
**TMC HOLDINGS & DEVELOPMENT 2, LLC**  
24 WILLIAM WAY  
BELLINGHAM, MA 02019

PROJECT:  
**25 FORGE PARKWAY**  
FRANKLIN, MA

PROJECT NO. 2712-02A	DATE: 02-21-23
SCALE: 1" = 40'	DWG. NAME: C-2712-02A
DESIGNED BY: SM/JRG	CHECKED BY: BDI

PREPARED BY:

**ALLEN & MAJOR ASSOCIATES, INC.**  
civil engineering • land surveying  
environmental consulting • landscape architecture  
www.allenmajor.com  
100 COMMERCE WAY, SUITE 5  
WOBURN, MA 01801  
TEL: (781) 935-6889  
FAX: (781) 935-2896

WOBURN, MA • LAKEVILLE, MA • MANCHESTER, NH

THIS DRAWING HAS BEEN PREPARED IN DIGITAL FORMAT. CLIENTS REPRESENTATIVE OR CONSULTANTS MAY BE PROVIDED COPIES OF DRAWINGS AND SPECIFICATIONS FOR HIS/HER INFORMATION AND/OR SPECIFIC USE ON THIS PROJECT. DUE TO THE POTENTIAL THAT THE PROVIDED INFORMATION MAY BE MODIFIED UNINTENTIONALLY OR OTHERWISE, ALLEN & MAJOR ASSOCIATES, INC. MAY REMOVE ALL INDICATION OF THE DOCUMENTS AUTHORITY ON THE DIGITAL MEDIA. PRINTED REPRESENTATIONS OR PORTABLE DOCUMENT FORMAT OF THE DRAWINGS AND SPECIFICATIONS ISSUED SHALL BE THE ONLY RECORD COPIES OF ALLEN & MAJOR ASSOCIATES, INC.'S WORK PRODUCT.

DRAWING TITLE: <b>LIGHTING PLAN</b>	SHEET No. <b>C-104</b>
--	---------------------------

Copyright © 2023 Allen & Major Associates, Inc. All Rights Reserved.



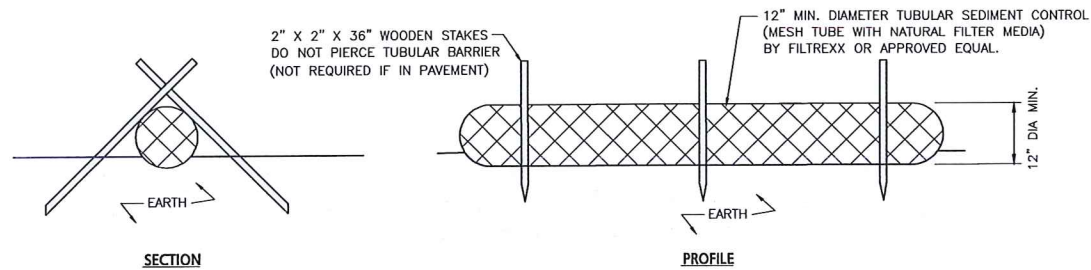

NOTES:

1. ALL MATERIALS TO MEET MANUFACTURERS SPECIFICATIONS.
2. INSTALL WOODEN STAKES IN A CRISS-CROSS PATTERN EVERY 8' ON CENTER.
3. OVERLAP TUBULAR BARRIER SEGMENTS A MINIMUM OF 12".
4. THE CONTRACTOR SHALL MAINTAIN THE TUBULAR BARRIERS IN A FUNCTIONAL CONDITION AT ALL TIMES. THE CONTROLS SHALL BE ROUTINELY INSPECTED BY THE CONTRACTOR.
5. WHERE THE TUBULAR BARRIERS REQUIRE REPAIR OR SEDIMENT REMOVAL, IT WILL BE COMPLETED BY THE CONTRACTOR AT NO ADDITIONAL COST.
6. AT A MINIMUM, THE CONTRACTOR SHALL REMOVE SEDIMENTS COLLECTED AT THE BASE WHEN THEY REACH 1/3 THE EXPOSED HEIGHT OF THE BARRIER.

**TUBULAR SEDIMENT BARRIER**  
NOT TO SCALE **1**

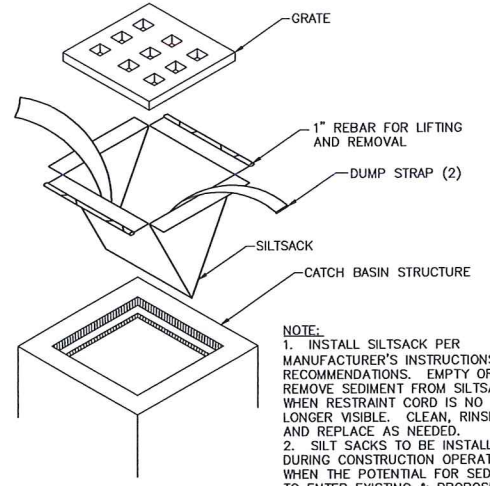

**CATCH BASIN FILTER INLET DETAIL**  
NOT TO SCALE **2**

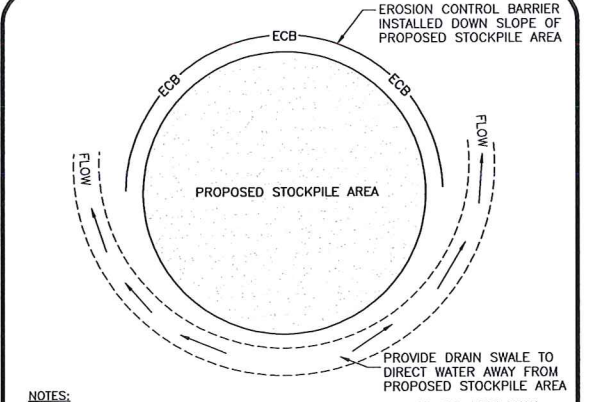

**STOCKPILE PROTECTION DETAIL**  
NOT TO SCALE **3**

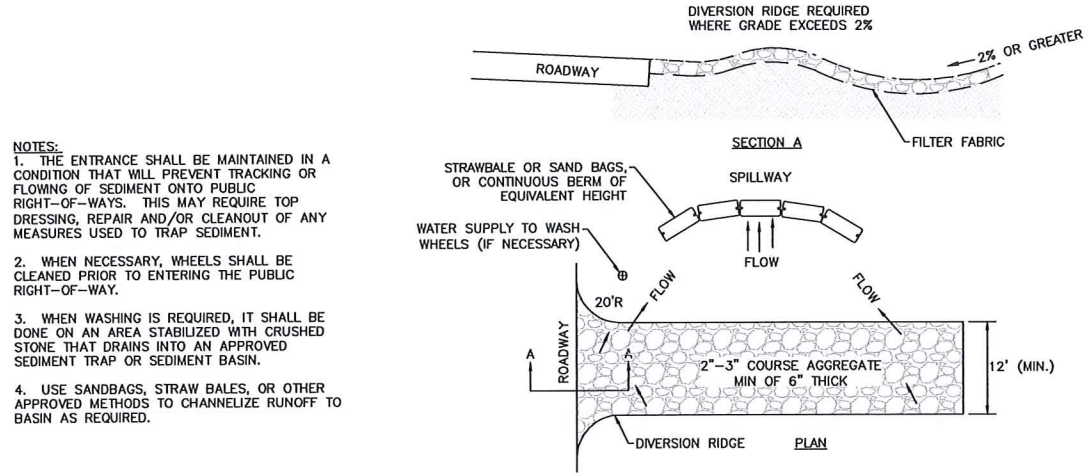

NOTES:

1. THE ENTRANCE SHALL BE MAINTAINED IN A CONDITION THAT WILL PREVENT TRACKING OR FLOWING OF SEDIMENT ONTO PUBLIC RIGHT-OF-WAYS. THIS MAY REQUIRE TOP DRESSING, REPAIR AND/OR CLEANOUT OF ANY MEASURES USED TO TRAP SEDIMENT.
2. WHEN NECESSARY, WHEELS SHALL BE CLEANED PRIOR TO ENTERING THE PUBLIC RIGHT-OF-WAY.
3. WHEN WASHING IS REQUIRED, IT SHALL BE DONE ON AN AREA STABILIZED WITH CRUSHED STONE THAT DRAINS INTO AN APPROVED SEDIMENT TRAP OR SEDIMENT BASIN.
4. USE SANDBAGS, STRAW BALES, OR OTHER APPROVED METHODS TO CHANNELIZE RUNOFF TO BASIN AS REQUIRED.

**TEMPORARY CONSTRUCTION ENTRANCE**  
NOT TO SCALE **4**

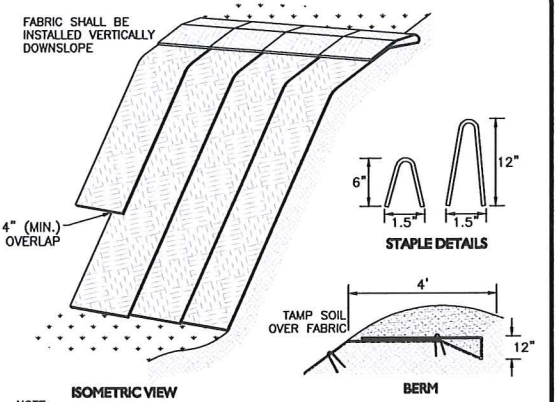

**EROSION CONTROL FABRIC**  
NOT TO SCALE **5**

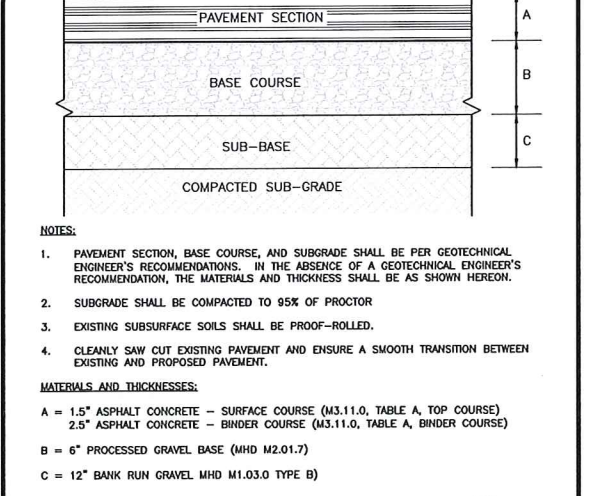

NOTES:

1. PAVEMENT SECTION, BASE COURSE, AND SUBGRADE SHALL BE PER GEOTECHNICAL ENGINEER'S RECOMMENDATIONS. IN THE ABSENCE OF A GEOTECHNICAL ENGINEER'S RECOMMENDATION, THE MATERIALS AND THICKNESS SHALL BE AS SHOWN HEREON.
  2. SUBGRADE SHALL BE COMPACTED TO 95% OF PROCTOR.
  3. EXISTING SUBSURFACE SOILS SHALL BE PROOF-ROLLED.
  4. CLEANLY SAW CUT EXISTING PAVEMENT AND ENSURE A SMOOTH TRANSITION BETWEEN EXISTING AND PROPOSED PAVEMENT.
- MATERIALS AND THICKNESSES:**
- A = 1.5" ASPHALT CONCRETE - SURFACE COURSE (M3.11.0, TABLE A, TOP COURSE)  
 B = 2.5" ASPHALT CONCRETE - BINDER COURSE (M3.11.0, TABLE A, BINDER COURSE)  
 C = 6" PROCESSED GRAVEL BASE (MHD M2.01.7)  
 D = 12" BANK RUN GRAVEL MHD M1.03.0 TYPE B)

**ASPHALT PAVEMENT SECTION**  
NOT TO SCALE **6**

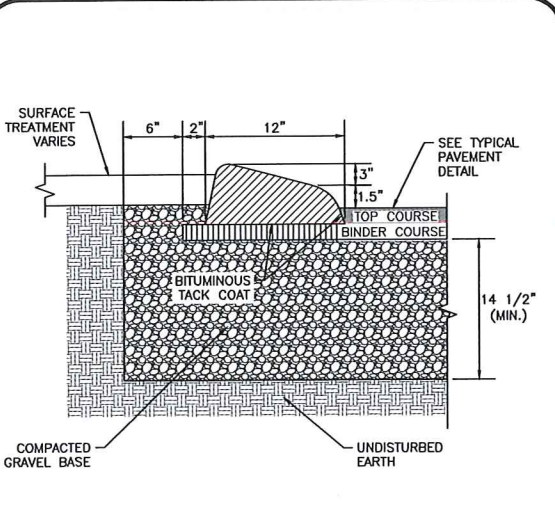

**CAPE COD BERM**  
NOT TO SCALE **7**

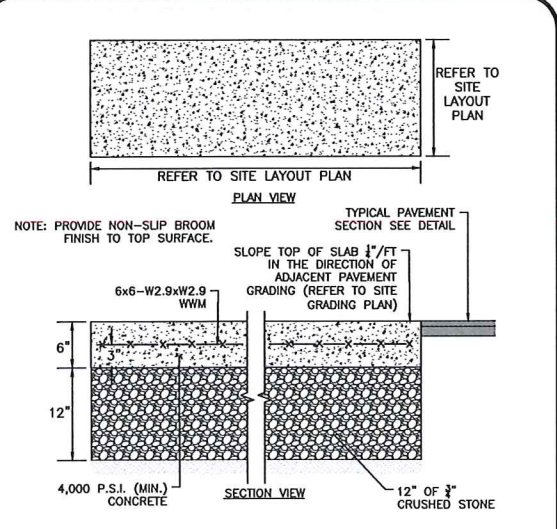

**CONCRETE DUMPSTER PAD**  
NOT TO SCALE **8**

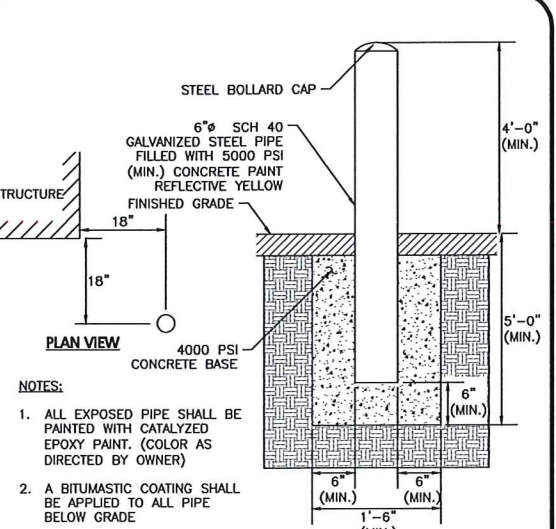

**FIXED BOLLARD**  
NOT TO SCALE **9**

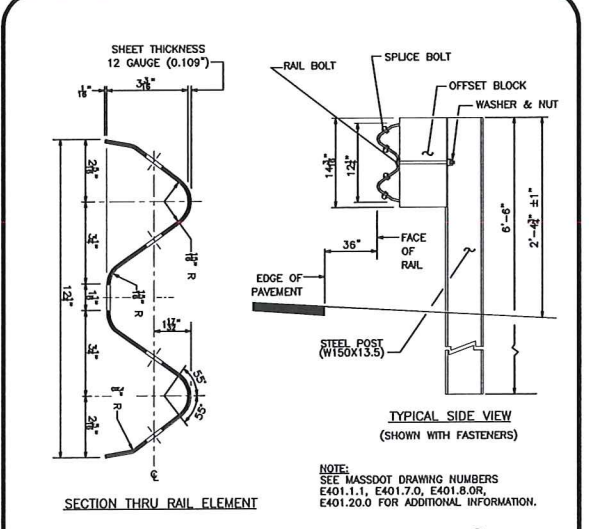

**STEEL GUARDRAIL**  
NOT TO SCALE **10**

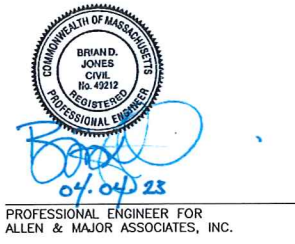

PROFESSIONAL ENGINEER FOR ALLEN & MAJOR ASSOCIATES, INC.

REV	DATE	DESCRIPTION
1	04-04-23	REVISION 1 PER PEER REVIEW

APPLICANT/OWNER:  
**TMC HOLDINGS & DEVELOPMENT 2, LLC**  
 24 WILLIAM WAY  
 BELLINGHAM, MA 02019

PROJECT:  
**25 FORGE PARKWAY**  
 FRANKLIN, MA

PROJECT NO.	2712-02A	DATE:	02-21-23
SCALE:	AS SHOWN	DWG. NAME:	C-2712-02A
DESIGNED BY:	SM/JRG	CHECKED BY:	BDJ



WOBURN, MA • LAKEVILLE, MA • MANCHESTER, NH

THIS DRAWING HAS BEEN PREPARED IN DIGITAL FORMAT. CLIENT/CUSTOMER'S REPRESENTATIVE OR CONSULTANTS MAY BE PROVIDED COPIES OF DRAWINGS AND SPECIFICATIONS FOR HIS/HER INFORMATION AND/OR SPECIFIC USE ON THIS PROJECT. DUE TO THE POTENTIAL THAT THE PROVIDED INFORMATION MAY BE MODIFIED UNINTENTIONALLY OR OTHERWISE, ALLEN & MAJOR ASSOCIATES, INC. MAY REMOVE ALL INDICATION OF THE DOCUMENT'S AUTHORSHIP ON THE DIGITAL MEDIA PRINTED REPRESENTATIONS OR PORTABLE DOCUMENT FORMAT OF THE DRAWINGS AND SPECIFICATIONS ISSUED SHALL BE THE ONLY RECORD COPIES OF ALLEN & MAJOR ASSOCIATES, INC.'S WORK PRODUCT.

DRAWING TITLE:	SHEET No.
<b>DETAILS</b>	<b>C-501</b>



R:\PROJECTS\2712-02A\CIVIL DRAWINGS\CURRENT\2712-02A-DETAILS.DWG

ACCEPTABLE FILL MATERIALS: STORMTECH MC-3500 CHAMBER SYSTEMS

MATERIAL LOCATION	DESCRIPTION	AASHTO MATERIAL CLASSIFICATIONS	COMPACTION / DENSITY REQUIREMENT
D	FINAL FILL: FILL MATERIAL FOR LAYER 'D' STARTS FROM THE TOP OF THE 'C' LAYER TO THE BOTTOM OF FLEXIBLE PAVEMENT OR UNPAVED FINISHED GRADE ABOVE. NOTE THAT PAVEMENT SUBBASE MAY BE PART OF THE 'D' LAYER.	N/A	PREPARE PER SITE DESIGN ENGINEER'S PLANS.
C	INITIAL FILL: FILL MATERIAL FOR LAYER 'C' STARTS FROM THE TOP OF THE EMBEDMENT STONE ('B' LAYER) TO 24" (600 mm) ABOVE THE TOP OF THE CHAMBER. NOTE THAT PAVEMENT SUBBASE MAY BE A PART OF THE 'C' LAYER.	AASHTO M145 <sup>1</sup> A-1, A-2-4, A-3  OR AASHTO M43 <sup>1</sup> 3, 357, 4, 467, 5, 56, 57, 6, 67, 68, 7, 78, 8, 89, 9, 10	BEGIN COMPACTIONS AFTER 24" (600 mm) OF MATERIAL OVER THE CHAMBERS IS REACHED. COMPACT ADDITIONAL LAYERS IN 12" (300 mm) MAX LIFTS TO A MIN. 95% PROCTOR DENSITY FOR WELL GRADED MATERIAL AND 95% RELATIVE DENSITY FOR PROCESSED AGGREGATE MATERIALS.
B	EMBEDMENT STONE: FILL SURROUNDING THE CHAMBERS FROM THE FOUNDATION STONE ('A' LAYER) TO THE 'C' LAYER ABOVE.	AASHTO M43 <sup>1</sup> 3, 4	
A	FOUNDATION STONE: FILL LAYER CHAMBERS FROM THE SUBGRADE UP TO THE FOOT (BOTTOM) OF THE CHAMBER.	AASHTO M43 <sup>1</sup> 3, 4	PLATE COMPACT OR ROLL TO ACHIEVE A FLAT SURFACE. <sup>2,3</sup>

PLEASE NOTE:

- THE LISTED AASHTO DESIGNATIONS ARE FOR GRADATIONS ONLY. THE STONE MUST ALSO BE CLEAN, CRUSHED, ANGULAR. FOR EXAMPLE, A SPECIFICATION FOR #4 STONE WOULD STATE: "CLEAN, CRUSHED, ANGULAR NO. 4 (AASHTO M43) STONE".
- STORMTECH COMPACTION REQUIREMENTS ARE MET FOR 'A' LOCATION MATERIALS WHEN PLACED AND COMPACTED IN 9" (230 mm) (MAX) LIFTS USING TWO FULL COVERS WITH A VIBRATORY COMPACTOR.
- WHERE INFILTRATION SURFACES MAY BE COMPROMISED BY COMPACTION, FOR STANDARD DESIGN LOAD CONDITIONS, A FLAT SURFACE MAY BE ACHIEVED BY RAKING OR DRAGGING WITHOUT COMPACTION EQUIPMENT. FOR SPECIAL LOAD DESIGNS, CONTACT STORMTECH FOR COMPACTION REQUIREMENTS.
- ONCE LAYER 'C' IS PLACED, ANY SOIL/MATERIAL CAN BE PLACED IN LAYER 'D' UP TO THE FINISHED GRADE. MOST PAVEMENT SUBBASE SOILS CAN BE USED TO REPLACE THE MATERIAL REQUIREMENTS OF LAYER 'C' OR 'D' AT THE SITE DESIGN ENGINEER'S DISCRETION.

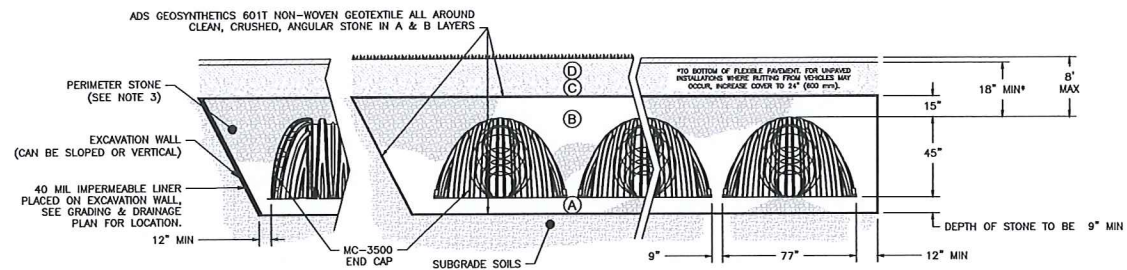

NOTES:

- CHAMBERS SHALL MEET THE REQUIREMENTS OF ASTM F2418, "STANDARD SPECIFICATION FOR POLYPROPYLENE (PP) CORRUGATED WALL STORMWATER COLLECTION CHAMBERS" CHAMBER CLASSIFICATION 45x76 DESIGNATION SS.
- MC-3500 CHAMBERS SHALL BE DESIGNED IN ACCORDANCE WITH ASTM F2787 "STANDARD PRACTICE FOR STRUCTURAL DESIGN OF THERMOPLASTIC CORRUGATED WALL STORMWATER COLLECTION CHAMBERS".
- PERIMETER STONE MUST BE EXTENDED HORIZONTALLY TO THE EXCAVATION WALL FOR BOTH VERTICAL AND SLOPED EXCAVATION WALLS.
- REQUIREMENTS FOR HANDLING AND INSTALLATION:
  - TO MAINTAIN THE WIDTH OF CHAMBERS DURING SHIPPING AND HANDLING, CHAMBERS SHALL HAVE INTEGRAL, INTERLOCKING STACKING LUGS.
  - TO ENSURE A SECURE JOINT DURING INSTALLATION AND BACKFILL, THE HEIGHT OF THE CHAMBER JOINT SHALL NOT BE LESS THAN 3".
  - TO ENSURE THE INTEGRITY OF THE ARCH SHAPE DURING INSTALLATION, a) THE ARCH STIFFNESS CONSTANT AS DEFINED IN SECTION 6.2.8 OF ASTM F2418 SHALL BE GREATER THAN OR EQUAL TO 500 LBS/FT<sup>2</sup>. AND b) TO RESIST CHAMBER DEFORMATION DURING INSTALLATION AT ELEVATED TEMPERATURES (ABOVE 73° F / 23° C), CHAMBERS SHALL BE PRODUCED FROM REFLECTIVE GOLD OR YELLOW COLORS.

MC-3500 STORMTECH CHAMBER SPECIFICATIONS

- CHAMBERS SHALL BE STORMTECH MC-3500.
- CHAMBERS SHALL BE ARCH-SHAPED AND SHALL BE MANUFACTURED FROM VIRGIN, IMPACT-MODIFIED POLYPROPYLENE COPOLYMERS.
- CHAMBERS SHALL MEET THE REQUIREMENTS OF ASTM F2418, "STANDARD SPECIFICATION FOR POLYPROPYLENE (PP) CORRUGATED WALL STORMWATER COLLECTION CHAMBERS" CHAMBER CLASSIFICATION 45x76 DESIGNATION SS.
- CHAMBER ROWS SHALL PROVIDE CONTINUOUS, UNOBSTRUCTED INTERNAL SPACE WITH NO INTERNAL SUPPORTS THAT WOULD IMPEDE FLOW OR LIMIT ACCESS FOR INSPECTION.
- THE STRUCTURAL DESIGN OF THE CHAMBERS, THE STRUCTURAL BACKFILL, AND THE INSTALLATION REQUIREMENTS SHALL ENSURE THAT THE LOAD FACTORS SPECIFIED IN THE AASHTO LRFD BRIDGE DESIGN SPECIFICATIONS, SECTION 12.12, ARE MET FOR: 1) LONG-DURATION DEAD LOADS AND 2) SHORT-DURATION LIVE LOADS, BASED ON THE AASHTO DESIGN TRUCK WITH CONSIDERATION FOR IMPACT AND MULTIPLE VEHICLE PRESENCES.
- CHAMBERS SHALL BE DESIGNED, TESTED AND ALLOWABLE LOAD CONFIGURATIONS DETERMINED IN ACCORDANCE WITH ASTM F2787, "STANDARD PRACTICE FOR STRUCTURAL DESIGN OF THERMOPLASTIC CORRUGATED WALL STORMWATER COLLECTION CHAMBERS". LOAD CONFIGURATIONS SHALL INCLUDE: 1) INSTANTANEOUS (<1 MIN) AASHTO DESIGN TRUCK LIVE LOAD ON MINIMUM COVER 2) MAXIMUM PERMANENT (75-YR) COVER LOAD AND 3) ALLOWABLE COVER WITH PARKED (1-WEEK) AASHTO DESIGN TRUCK.
- REQUIREMENTS FOR HANDLING AND INSTALLATION:
  - TO MAINTAIN THE WIDTH OF CHAMBERS DURING SHIPPING AND HANDLING, CHAMBERS SHALL HAVE INTEGRAL, INTERLOCKING STACKING LUGS.
  - TO ENSURE A SECURE JOINT DURING INSTALLATION AND BACKFILL, THE HEIGHT OF THE CHAMBER JOINT SHALL NOT BE LESS THAN 3".
  - TO ENSURE THE INTEGRITY OF THE ARCH SHAPE DURING INSTALLATION, a) THE ARCH STIFFNESS CONSTANT SHALL BE GREATER THAN OR EQUAL TO 500 LBS/FT<sup>2</sup>. THE ASS IS DEFINED IN SECTION 6.2.8 OF ASTM F2418. AND b) TO RESIST CHAMBER DEFORMATION DURING INSTALLATION AT ELEVATED TEMPERATURES (ABOVE 73° F / 23° C), CHAMBERS SHALL BE PRODUCED FROM REFLECTIVE GOLD OR YELLOW COLORS.
- ONLY CHAMBERS THAT ARE APPROVED BY THE SITE DESIGN ENGINEER WILL BE ALLOWED. UPON REQUEST BY THE SITE DESIGN ENGINEER OR OWNER, THE CHAMBER MANUFACTURER SHALL SUBMIT A STRUCTURAL EVALUATION FOR APPROVAL BEFORE DELIVERING CHAMBERS TO THE PROJECT SITE AS FOLLOWS:
  - THE STRUCTURAL EVALUATION SHALL BE SEALED BY A REGISTERED PROFESSIONAL ENGINEER.
  - THE STRUCTURAL EVALUATION SHALL DEMONSTRATE THAT THE SAFETY FACTORS ARE GREATER THAN OR EQUAL TO 1.95 FOR DEAD LOAD AND 1.75 FOR LIVE LOAD, THE MINIMUM REQUIRED BY ASTM F2787 AND BY SECTIONS 3 AND 12.12 OF THE AASHTO LRFD BRIDGE DESIGN SPECIFICATIONS FOR THERMOPLASTIC PIPE.
  - THE TEST DERIVED CREEP MODULUS AS SPECIFIED IN ASTM F2418 SHALL BE USED FOR PERMANENT DEAD LOAD DESIGN EXCEPT THAT IT SHALL BE THE 75-YEAR MODULUS USED FOR DESIGN.
- CHAMBERS AND END CAPS SHALL BE PRODUCED AT AN ISO 9001 CERTIFIED MANUFACTURING FACILITY.



STORMTECH MC-3500 CHAMBER SYSTEM  
NOT TO SCALE

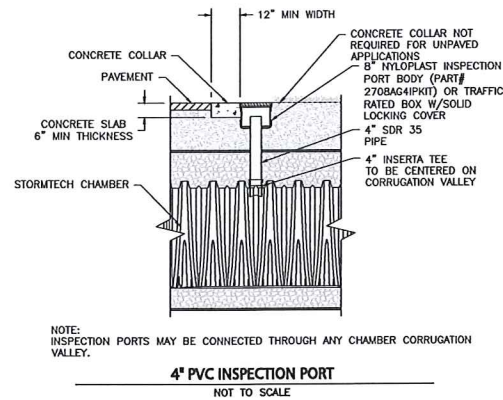

4\"/>

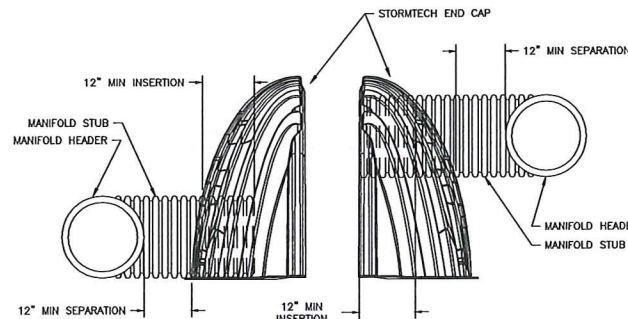

END CAP INSERTION DETAIL  
NOT TO SCALE

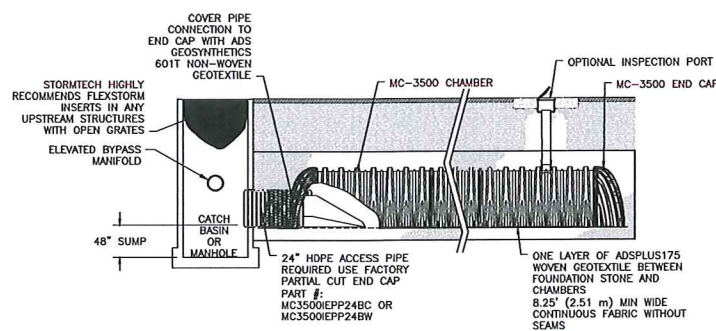

MC-3500 - ISOLATOR ROW PLUS DETAIL  
NOT TO SCALE

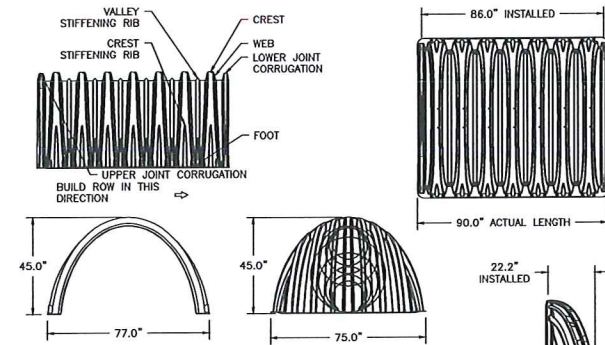

NOMINAL CHAMBER SPECIFICATIONS

SIZE (W X H X INSTALLED LENGTH)	CHAMBER STORAGE	MINIMUM INSTALLED STORAGE*	WEIGHT
77.0" X 45.0" X 86.0"	109.9 CUBIC FEET	175.0 CUBIC FEET	134 lbs.
75.0" X 45.0" X 22.2"	14.9 CUBIC FEET	45.1 CUBIC FEET	49 lbs.

\*ASSUMES 12" STONE ABOVE, 9" STONE FOUNDATION, 6" STONE BETWEEN CHAMBERS, 6" STONE PERIMETER IN FRONT OF END CAPS AND 40% STONE POROSITY.

PARTIAL CUT HOLES AT BOTTOM OF END CAP FOR PART NUMBERS ENDING WITH "B"  
PARTIAL CUT HOLES AT TOP OF END CAP FOR PART NUMBERS ENDING WITH "T"  
END CAPS WITH A PREFABRICATED WELDED STUB END WITH "M"  
END CAPS WITH A WELDED CROWN PLATE END WITH "C"

PART #	STUB	B	C
MC3500IEPP06T	6" (150 mm)	33.21" (844 mm)	---
MC3500IEPP06B	---	0.66" (17 mm)	---
MC3500IEPP08T	8" (200 mm)	31.16" (791 mm)	---
MC3500IEPP08B	---	0.81" (21 mm)	---
MC3500IEPP10T	10" (250 mm)	29.04" (738 mm)	---
MC3500IEPP10B	---	0.93" (24 mm)	---
MC3500IEPP12T	12" (300 mm)	26.36" (670 mm)	---
MC3500IEPP12B	---	1.35" (34 mm)	---
MC3500IEPP15T	15" (375 mm)	23.39" (594 mm)	---
MC3500IEPP15B	---	1.50" (38 mm)	---
MC3500IEPP18TC	---	20.03" (509 mm)	---
MC3500IEPP18TW	---	---	---
MC3500IEPP18BC	---	1.77" (45 mm)	---
MC3500IEPP18BW	---	---	---
MC3500IEPP24TC	---	14.48" (368 mm)	---
MC3500IEPP24TW	---	---	---
MC3500IEPP24BC	---	2.06" (52 mm)	---
MC3500IEPP24BW	---	---	---
MC3500IEPP30BC	30" (750 mm)	---	2.75" (70 mm)

NOTE: ALL DIMENSIONS ARE NOMINAL

TECHNICAL SPECIFICATIONS  
NOT TO SCALE

INSPECTION & MAINTENANCE

- STEP 1) INSPECT ISOLATOR ROW PLUS FOR SEDIMENT
- INSPECTION PORTS (IF PRESENT)
    - REMOVE/OPEN LID ON NYLOPLAST INLINE DRAIN
    - REMOVE AND CLEAN FLEXSTORM FILTER IF INSTALLED
    - USING A FLASHLIGHT AND STADA ROD, MEASURE DEPTH OF SEDIMENT AND RECORD ON MAINTENANCE LOG
    - LOWER A CAMERA INTO ISOLATOR ROW PLUS FOR VISUAL INSPECTION OF SEDIMENT LEVELS (OPTIONAL)
    - IF SEDIMENT IS AT, OR ABOVE, 3" (80 mm) PROCEED TO STEP 2. IF NOT, PROCEED TO STEP 3.
  - ALL ISOLATOR PLUS ROWS
    - REMOVE COVER FROM STRUCTURE AT UPSTREAM END OF ISOLATOR ROW PLUS
    - USING A FLASHLIGHT, INSPECT DOWN THE ISOLATOR ROW PLUS THROUGH OUTLET PIPE
      - MIRRORS ON POLES OR CAMERAS MAY BE USED TO AVOID A CONFINED SPACE ENTRY
      - FOLLOW OSHA REGULATIONS FOR CONFINED SPACE ENTRY IF ENTERING MANHOLE
    - IF SEDIMENT IS AT, OR ABOVE, 3" (80 mm) PROCEED TO STEP 2. IF NOT, PROCEED TO STEP 3.
- STEP 2) CLEAN OUT ISOLATOR ROW PLUS USING THE JETVAC PROCESS
- A FIXED CULVERT CLEANING NOZZLE WITH REAR FACING SPREAD OF 45° (1.1 m) OR MORE IS PREFERRED
  - APPLY MULTIPLE PASSES OF JETVAC UNTIL BACKFLUSH WATER IS CLEAN
  - VACUUM STRUCTURE SUMP AS REQUIRED
- STEP 3) REPLACE ALL COVERS, GRATES, FILTERS, AND LIDS; RECORD OBSERVATIONS AND ACTIONS.
- STEP 4) INSPECT AND CLEAN BASIN AND MANHOLES UPSTREAM OF THE STORMTECH SYSTEM.

NOTES

- INSPECT EVERY 6 MONTHS DURING THE FIRST YEAR OF OPERATION. ADJUST THE INSPECTION INTERVAL BASED ON PREVIOUS OBSERVATIONS OF SEDIMENT ACCUMULATION AND HIGH WATER ELEVATIONS.
- CONDUCT JETTING AND VACUUMING ANNUALLY OR WHEN INSPECTION SHOWS THAT MAINTENANCE IS NECESSARY.



PROFESSIONAL ENGINEER FOR ALLEN & MAJOR ASSOCIATES, INC.

REV	DATE	DESCRIPTION
1	04-04-23	REVISION 1 PER PEER REVIEW

APPLICANT/OWNER:  
TMC HOLDINGS & DEVELOPMENT 2, LLC  
24 WILLIAM WAY  
BELLINGHAM, MA 02019

PROJECT:  
25 FORGE PARKWAY  
FRANKLIN, MA

PROJECT NO.	2712-02A	DATE:	02-21-23
SCALE:	AS SHOWN	DWG. NAME:	C-2712-02A
DESIGNED BY:	SM/JRG	CHECKED BY:	BDJ

PREPARED BY:

**ALLEN & MAJOR ASSOCIATES, INC.**  
civil engineering • land surveying  
environmental consulting • landscape architecture  
w w w . a l l e n & m a j o r . c o m  
100 COMMERCE WAY, SUITE 5  
WOBBURN MA 01801  
TEL: (781) 935-6889  
FAX: (781) 935-2896

WOBBURN, MA • LAKEVILLE, MA • MANCHESTER, NH

THIS DRAWING HAS BEEN PREPARED IN DIGITAL FORMAT. CLIENTS/CLIENTS REPRESENTATIVE OR CONSULTANTS MAY BE PROVIDED COPIES OF DRAWINGS AND SPECIFICATIONS FOR HIS/HER INFORMATION AND/OR SPECIFIC USE ON THIS PROJECT. DUE TO THE POTENTIAL THAT THE PROVIDED INFORMATION MAY BE MODIFIED UNINTENTIONALLY OR OTHERWISE, ALLEN & MAJOR ASSOCIATES, INC. MAY REMOVE ALL INDICATION OF THE DOCUMENTS AUTHORITY ON THE DIGITAL MEDIA PRINTED REPRESENTATIONS OR PORTABLE DOCUMENT FORMAT OF THE DRAWINGS AND SPECIFICATIONS ISSUED SHALL BE THE ONLY RECORD COPIES OF ALLEN & MAJOR ASSOCIATES, INC.'S WORK PRODUCT.

DRAWING TITLE:	SHEET No.
DETAILS	C-502



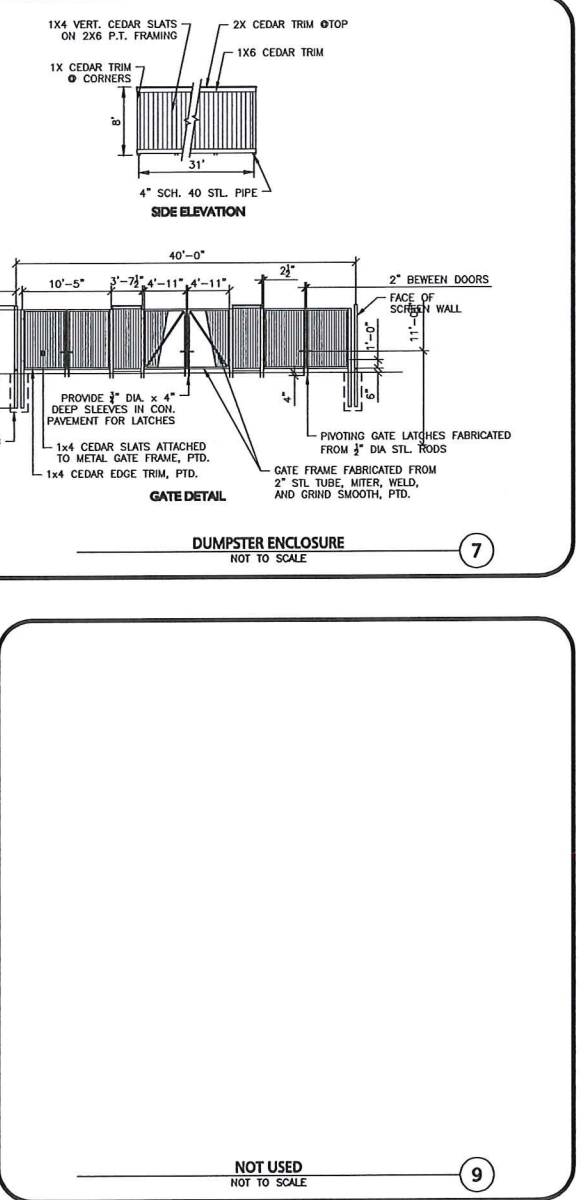
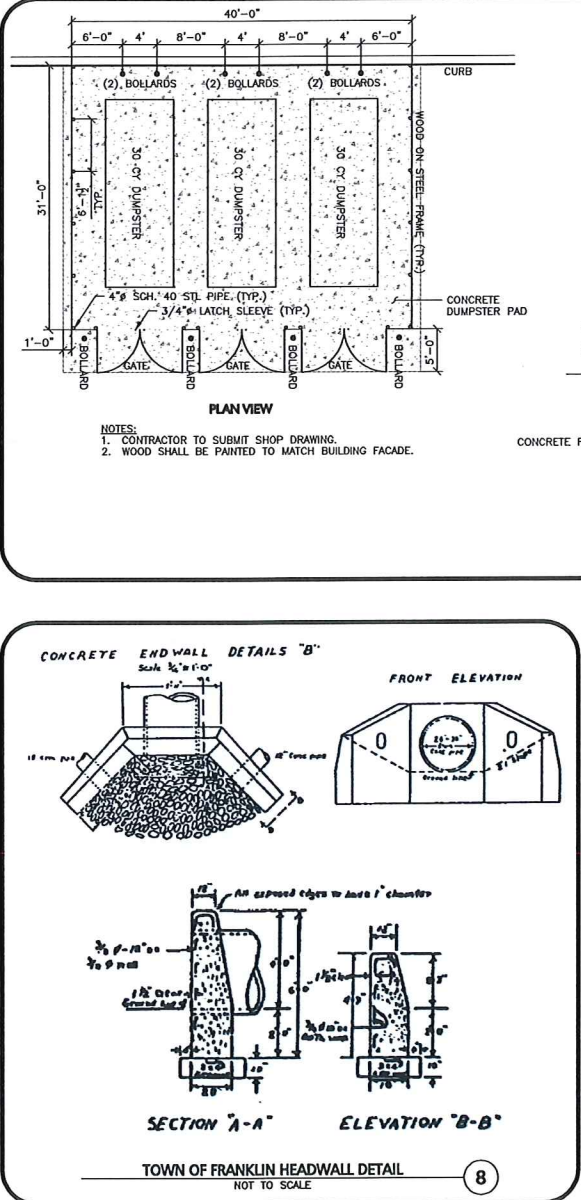
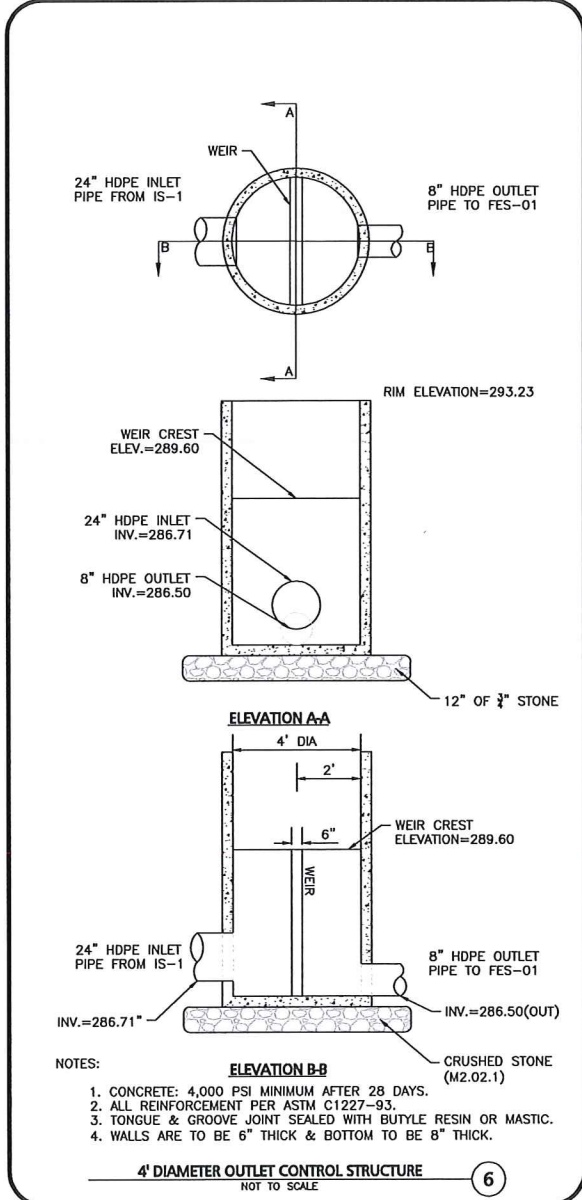
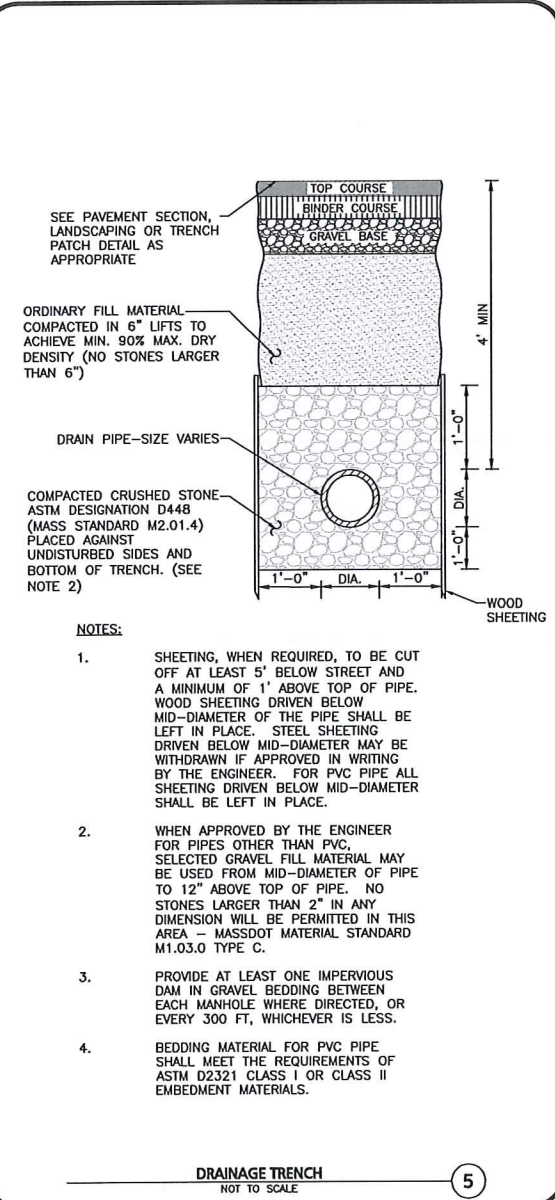
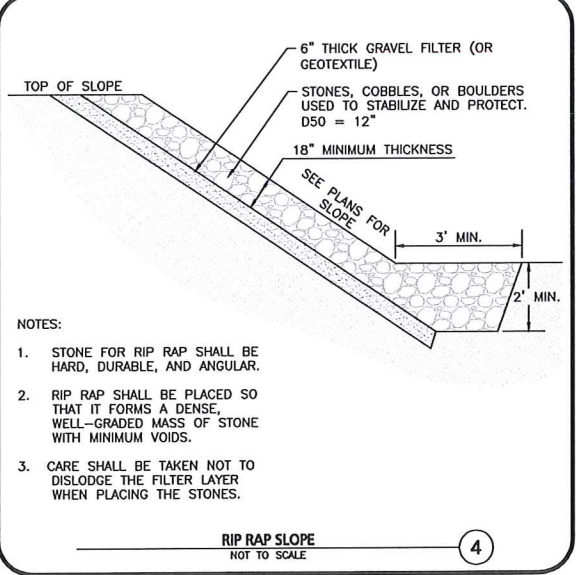
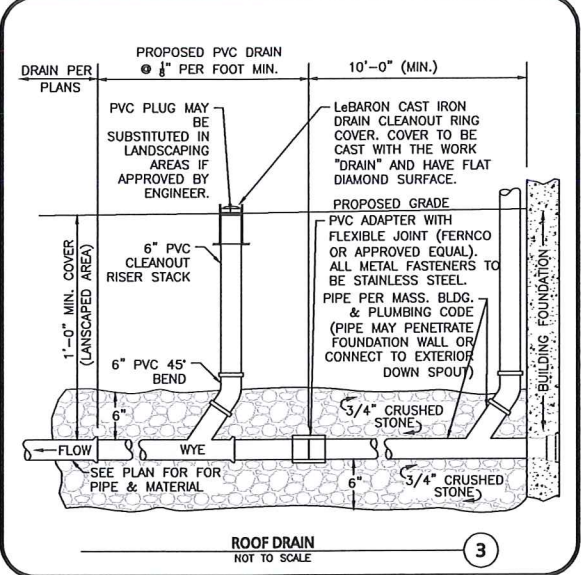
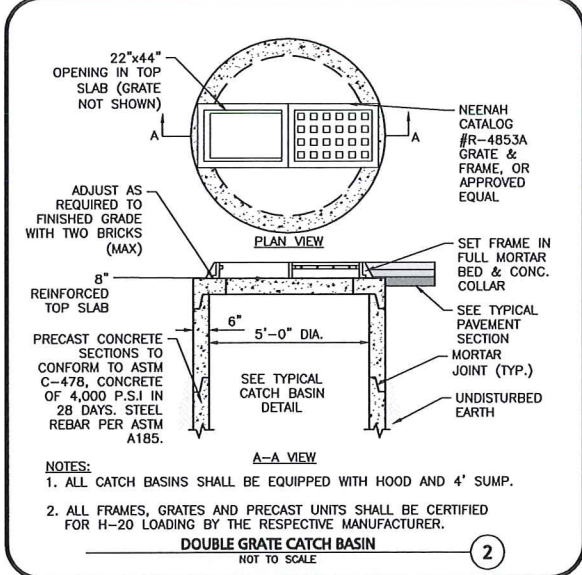
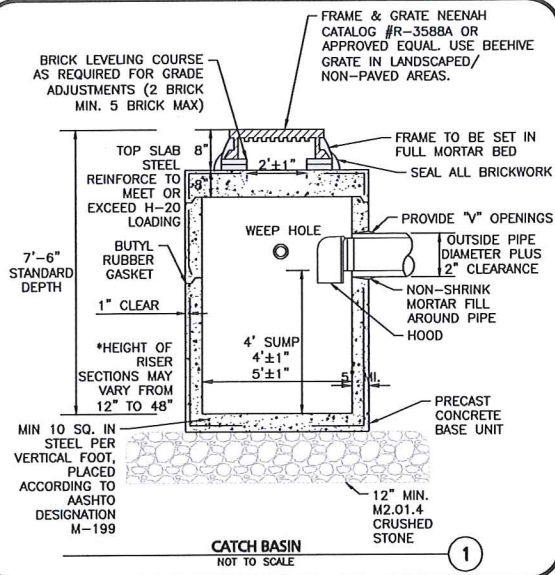

**BRIAN D. JONES**  
 CIVIL ENGINEER  
 No. 42919  
 REGISTERED PROFESSIONAL ENGINEER  
 04.04.23  
 PROFESSIONAL ENGINEER FOR  
 ALLEN & MAJOR ASSOCIATES, INC.

REV	DATE	DESCRIPTION
1	04-04-23	REVISION 1 PER PEER REVIEW

**APPLICANT/OWNER:**  
 TMC HOLDINGS & DEVELOPMENT 2, LLC  
 24 WILLIAM WAY  
 BELLINGHAM, MA 02019

**PROJECT:**  
 25 FORGE PARKWAY  
 FRANKLIN, MA

PROJECT NO.	2712-02A	DATE:	02-21-23
SCALE:	AS SHOWN	DWG. NAME:	C2712-02A
DESIGNED BY:	SM/JRG	CHECKED BY:	BDJ

**ALLEN & MAJOR ASSOCIATES, INC.**  
 civil engineering • land surveying  
 environmental consulting • landscape architecture  
 w w w . a l l e n & m a j o r . c o m  
 100 COMMERCE WAY, SUITE 5  
 WOBURN MA 01801  
 TEL: (781) 935-6889  
 FAX: (781) 935-2896

WOBURN, MA • LAKEVILLE, MA • MANCHESTER, NH

THIS DRAWING HAS BEEN PREPARED IN DIGITAL FORMAT. CLIENTS/CLIENTS REPRESENTATIVE OR CONSULTANTS MAY BE PROVIDED COPIES OF DRAWINGS AND SPECIFICATIONS FOR HIS/HER INFORMATION AND/OR SPECIFIC USE ON THIS PROJECT. DUE TO THE POTENTIAL THAT THE PROVIDED INFORMATION MAY BE MODIFIED UNINTENTIONALLY OR OTHERWISE, ALLEN & MAJOR ASSOCIATES, INC. MAY REMOVE ALL INDICATION OF THE DOCUMENTS' AUTHORSHIP ON THE DIGITAL MEDIA PRINTED REPRESENTATIONS OR PORTABLE DOCUMENT FORMAT OF THE DRAWINGS AND SPECIFICATIONS ISSUED SHALL BE THE ONLY RECORD COPIES OF ALLEN & MAJOR ASSOCIATES, INC.'S WORK PRODUCT.

DRAWING TITLE:	SHEET No.
DETAILS	C-503

Copyright © 2023 Allen & Major Associates, Inc. All Rights Reserved.



**PLANTING SCHEDULE**

DECIDUOUS AND FLOWERING TREES						
KEY	QUANTITY	BOTANICAL NAME	COMMON NAME	MIN. SIZE	SPACING	COMMENTS
AR	2	ACER RUBRUM 'AUTUMN RADIANCE'	AUTUMN RADIANCE MAPLE	2.5"-3" CAL.	AS SHOWN	B&B
SHRUBS						
IV	15	ILEX VERTICILLATA	WINTERBERRY	#5	AS SHOWN	POT
VM	2	ILEX VERTICILLATA MALE POLLINATOR	MALE WINTERBERRY	#3	AS SHOWN	POT
SD	3	SALIX DISCOLOR	PUSSYWILLOW	#10	AS SHOWN	POT
VL	3	VIBURNUM LENTAGO	NANNYBERRY VIBURNUM	#10	AS SHOWN	POT
PERENNIALS						
RF	40	RUDBECKIA FULGIDA VAR. FULGIDA	BLACK EYED SUSAN	#1	AS SHOWN	POT

**LEGEND**

- DECIDUOUS TREE
- EXISTING TREE
- FLOWERING TREE
- SHRUBS
- MULCH BED
- PERENNIALS/GROUNDCOVER
- EROSION CONTROL SEED MIX



**LANDSCAPE NOTES**

- ALL WORK SHALL BE IN ACCORDANCE WITH THE REQUIREMENTS OF THE CITY OF FRANKLIN, MA.
- PLANTING PLAN IS DIAGRAMMATIC IN NATURE. FINAL PLACEMENT OF PLANTS TO BE APPROVED BY THE LANDSCAPE ARCHITECT IN THE FIELD.
- THE CONTRACTOR SHALL BE RESPONSIBLE FOR CONTACTING ALL UTILITY COMPANIES, ANY PERMITTING AGENCIES, AND "DIG-SAFE" (1-888-344-7233) AT LEAST 72 HOURS IN ADVANCE OF ANY WORK THAT WILL REQUIRE EXCAVATION. CONTRACTOR SHALL NOTIFY THE OWNERS REPRESENTATIVE OF ANY CONFLICTS IN WRITING.
- NO PLANT MATERIAL SHALL BE INSTALLED UNTIL ALL GRADING AND CONSTRUCTION HAS BEEN COMPLETED IN THE IMMEDIATE AREA, ANY TREES NOTED AS "SEAL OR SELECTED SPECIMEN" SHALL BE TAGGED AND SEALED BY THE LANDSCAPE ARCHITECT.
- ALL TREES SHALL BE BALLED AND BURLAPPED (B&B) UNLESS OTHERWISE NOTED OR APPROVED BY THE OWNER'S REPRESENTATIVE AND LANDSCAPE ARCHITECT.
- CONTRACTOR SHALL VERIFY QUANTITIES SHOWN ON PLANT LIST. QUANTITIES SHOWN ON PLANS SHALL GOVERN OVER PLANT LIST.
- ANY PROPOSED PLANT SUBSTITUTIONS MUST BE APPROVED IN WRITING BY OWNER'S REPRESENTATIVE AND LANDSCAPE ARCHITECT.
- ALL PLANT MATERIALS INSTALLED SHALL MEET THE GUIDELINES ESTABLISHED BY THE STANDARDS FOR NURSERY STOCK PUBLISHED BY THE AMERICAN ASSOCIATION OF NURSERYMEN.
- ALL PLANT MATERIALS SHALL BE GUARANTEED FOR ONE YEAR FOLLOWING DATE OF ACCEPTANCE.
- ALL DISTURBED AREAS NOT OTHERWISE NOTED SHALL RECEIVE 6" OF SUITABLE LOAM & SEED LAWNS WITH 3:1 OR GREATER SLOPES SHALL BE PROTECTED WITH AN EROSION CONTROL BLANKET.
- ANY FALL TRANSPLANTING HAZARD PLANTS SHALL BE DUG IN THE SPRING AND STORED FOR FALL PLANTING.
- TREES SHALL HAVE A MINIMUM CALIPER AS INDICATED ON THE PLANTING SCHEDULE TAKEN ONE FOOT ABOVE THE ROOT CROWN.
- ALL PLANT BEDS AND TREE SAUCERS TO RECEIVE 3" OF PINE BARK MULCH. GROUND COVER AREAS SHALL RECEIVE 1" OF PINE BARK MULCH.
- ALL DECIDUOUS TREES ADJACENT TO WALKWAYS AND ROADWAYS SHALL HAVE A BRANCHING PATTERN TO ALLOW FOR A MINIMUM OF 7' OF CLEARANCE BETWEEN THE GROUND AND THE LOWEST BRANCH.
- ALL TREE STAKES SHALL BE STAINED DARK BROWN.
- CONTRACTOR RESPONSIBLE FOR WATERING, AND RESEEDING OF BARE SPOTS UNTIL A UNIFORM STAND OF VEGETATION IS ESTABLISHED AND ACCEPTED.
- ALL PARKING ISLANDS PLANTED WITH SHRUBS SHALL HAVE 24" OF TOP SOIL. FINISH GRADE SHALL BE EQUAL TO THE TOP OF CURB.
- SOIL SAMPLES, TESTS, AND SHOP DRAWINGS SHALL BE PROVIDED TO THE LANDSCAPE ARCHITECT OR THE OWNER FOR APPROVAL PRIOR TO CONSTRUCTION.
- ALL PROPOSED LANDSCAPE AREAS INCLUDING MOWED LAWNS, TREES, SHRUB BEDS, AND PERENNIALS SHALL BE PROVIDED WITH WATER EFFICIENT UNDERGROUND IRRIGATION. DESIGN AND INSTALLATION OF IRRIGATION SYSTEM TO BE PERFORMED BY AN APPROVED IRRIGATION DESIGN BUILD CONTRACTOR OR BY AN APPROVED EQUAL, TO BE DETERMINED BY THE OWNERS REPRESENTATIVE AND LANDSCAPE ARCHITECT. IRRIGATION SYSTEM IS TO BE DESIGNED FOR EFFICIENT WATER USAGE INCLUDING: USE OF DRIP IRRIGATION FOR SHRUBS AND PERENNIALS, IRRIGATION SYSTEM WITH HEAD-TO-HEAD COVERAGE, A CENTRAL SHUT-OFF VALVE, SEPARATE ZONES FOR EACH TYPE OF BEDDING AREA BASED ON WATERING NEEDS, AND A RAIN SENSOR TO SHUT OFF IRRIGATION DURING RAIN EVENTS.

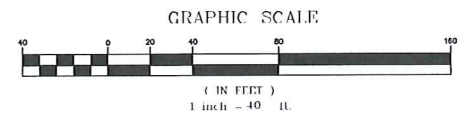
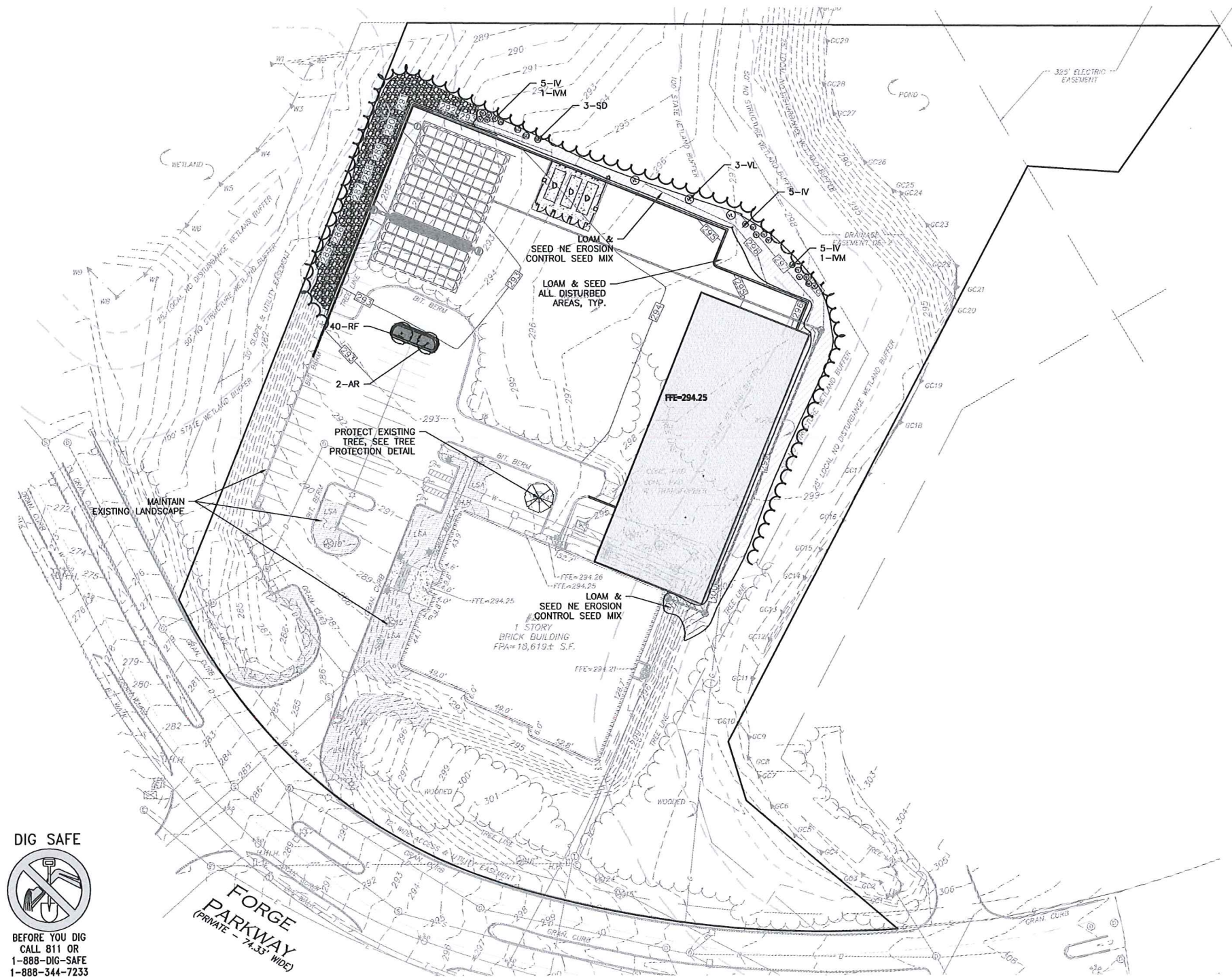

**DIG SAFE**  
  
 BEFORE YOU DIG  
 CALL 811 OR  
 1-888-DIG-SAFE  
 1-888-344-7233

**FORGE PARKWAY**  
 (PRIVATE - 74.35' WIDE)



PROFESSIONAL LANDSCAPE ARCHITECT FOR ALLEN & MAJOR ASSOCIATES, INC.

REV	DATE	DESCRIPTION
1	04-04-23	REVISION 1 PER PEER REVIEW

APPLICANT/OWNER:  
**TMC HOLDINGS & DEVELOPMENT 2, LLC**  
 24 WILLIAM WAY  
 BELLINGHAM, MA 02019

PROJECT:  
**25 FORGE PARKWAY**  
 FRANKLIN, MA

PROJECT NO. 2712-02A DATE: 02-21-23  
 SCALE: 1" = 40' DWG. NAME: 25FORGE.DWG  
 DESIGNED BY: SMJ/BRB CHECKED BY: BDJ

PREPARED BY:

**ALLEN & MAJOR ASSOCIATES, INC.**  
 civil engineering • land surveying  
 environmental consulting • landscape architecture  
 www.allenmajor.com  
 100 COMMERCE WAY, SUITE 5  
 WOBURN, MA 01801  
 TEL: (781) 935-6889  
 FAX: (781) 935-2896

WOBURN, MA • LAKEVILLE, MA • MANCHESTER, NH  
 THIS DRAWING HAS BEEN PREPARED IN DIGITAL FORMAT. CLIENT/CLIENTS REPRESENTATIVE OR CONSULTANTS MAY BE PROVIDED COPIES OF DRAWINGS AND SPECIFICATIONS FOR HIS/HER INFORMATION AND/OR SPECIFIC USE ON THIS PROJECT. DUE TO THE POTENTIAL THAT THE PROVIDED INFORMATION MAY BE MODIFIED UNINTENTIONALLY OR OTHERWISE, ALLEN & MAJOR ASSOCIATES, INC. MAY REMOVE ALL INDICATION OF THE DOCUMENT'S AUTHORSHIP ON THE DIGITAL MEDIA. PRINTED REPRESENTATIONS OR PORTABLE DOCUMENT FORMAT OF THE DRAWINGS AND SPECIFICATIONS ISSUED SHALL BE THE ONLY RECORD COPIES OF ALLEN & MAJOR ASSOCIATES, INC.'S WORK PRODUCT.

DRAWING TITLE: **LANDSCAPE PLAN** SHEET No. **L-101**

Copyright © 2023 Allen & Major Associates, Inc. All Rights Reserved.

R:\PROJECTS\2712-02A\CIVIL\DRAWINGS\CURRENT\2712-02A\_LANDSCAPE.DWG



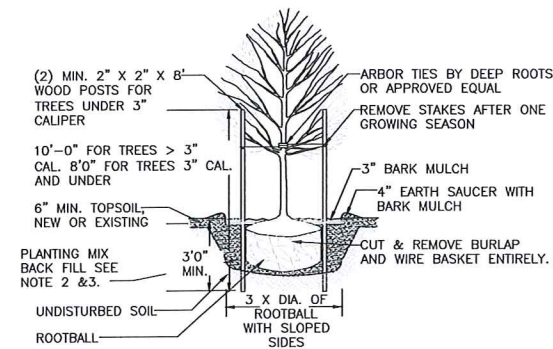

**NOTES:**

- ALL TREES SHALL HAVE THE SAME RELATIONSHIP TO FINISH GRADE AFTER PLANTING AS THEY HAD AT THE ORIGINAL NURSERY SETTING. ROOT FLARE SHALL BE 2" ABOVE FINISH GRADE. REMOVE SOIL FROM TRUNK FLARE OF TREE TO DETERMINE ACTUAL ROOTBALL AREA.
- BACKFILL WITH PLANTING MIX. PLANT MIX TO BE: 50% NATIVE TOPSOIL, 20% COMPOST (LEAVES & ORGANIC MATERIAL, NO ASH) 20% PEAT MOSS, 10% SAND.
- ADD MYCORRHIZA SOIL ADDITIVES AND SLOW RELEASE FERTILIZER WHEN PLANT HOLES ARE 50% FILLED AND WATER THOROUGHLY AT COMPLETION.

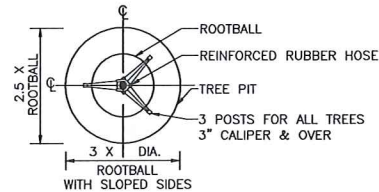

**DECIDUOUS TREE PLANTING DETAIL**  
 NOT TO SCALE

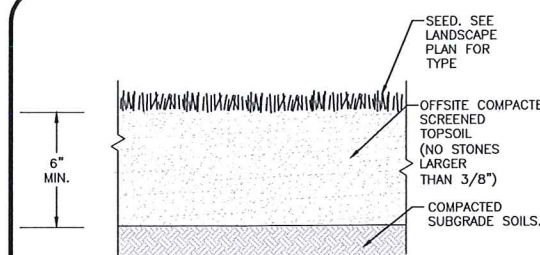

TEXTURE CLASS	% OF TOTAL WEIGHT
SAND	45% - 65%
SILT	15% - 35%
CLAY	5% - 20%

SIEVE	% PASSING
3/8"	100
NO. 4	85-100
NO. 40	60-85
NO. 100	38-60
NO. 200	10-35
20 um	LESS THAN 5%

**NOTES:**

- TOP OF LOAM (TOPSOIL) IS FINISH GRADE.
- ALL TOPSOIL (BOTH ONSITE AND OFFSITE SOURCES) SHALL BE COMPOSED OF A NATURAL, FERTILE, FRIABLE SOIL TYPICAL OF CULTIVATED TOPSOILS OF THE LOCALITY. OFFSITE SOIL SHALL BE SUITABLE FOR THE GERMINATION OF SEEDS AND SUPPORT OF VEGETATIVE GROWTH, WITH ADDITIVES, IF REQUIRED, TO ACHIEVE PARTICLE DISTRIBUTION AND ORGANIC CONTENT BELOW. TOPSOIL SHALL BE TAKEN FROM A WELL-DRAINED, ARIABLE SITE, FREE OF SUBSOIL, LARGE STONES, EARTH CLODS, STICKS, STUMPS, CLAY LUMPS, ROOTS, OTHER OBJECTIONABLE, EXTRANEIOUS MATTER OR DEBRIS NOR CONTAIN TOXIC SUBSTANCES.
- THE CONTRACTOR SHALL PROVIDE THE OWNER / LANDSCAPE ARCHITECT WITH TOPSOIL TEST RESULTS (RECOMMEND UMASS AMHERST SOIL TESTING LAB) FOR APPROVAL PRIOR TO OBTAINING AND PLACING THE SOIL. IF ANY TOPSOIL IS PURCHASED OR PLACED PRIOR TO APPROVAL BY OWNER / LANDSCAPE ARCHITECT, IT IS AT CONTRACTORS RISK, AND IT CAN BE REMOVED AT NO ADDITIONAL COST TO THE OWNER. IF THE PLANTING SOIL (BOTH ONSITE AND OFFSITE SOURCES) DOES NOT FALL WITHIN THE REQUIRED SIEVE ANALYSIS, TEXTURAL CLASS, ORGANIC CONTENT, OR PH RANGE, IT SHALL BE ADJUSTED TO MEET THE SPECIFICATIONS THROUGH THE ADDITION OF SAND, COMPOST, LIMESTONE, OR ALUMINUM SULFATE TO BRING IT WITHIN THE SPECIFIED LIMITS AT NO ADDITIONAL COST TO THE OWNER.
- TOPSOIL SHALL HAVE A PH VALUE BETWEEN 5.5 AND 6.5. TOPSOIL SHALL CONTAIN BETWEEN 4% AND 8% ORGANIC MATTER OF TOTAL DRY WEIGHT AND SHALL CONFORM TO THE FOLLOWING GRADATION AND TEXTURE CLASS ABOVE.

**TOPSOIL FOR LAWN, TREES, SHRUBS, & PERENNIALS**  
 NOT TO SCALE

**LOAM AND SEEDING NOTES:**

CONTRACTOR SHALL SEED ALL DISTURBED AREAS NOT NOTED TO RECEIVE OTHER MATERIALS, AND AT AREAS SHOWN ON THE PLAN PER SPECIFICATIONS BELOW

SCIENTIFIC NAME	COMMON NAME	PROPORTION BY WEIGHT	PERCENT PURITY	PERCENT GERMINATION
FESTUCA RUBRA "RUBRA"	CREeping RED FESCUE	37%	95%	90%
PAO PRAENTENSIS "BARON"	BARON KENTUCKY BLUEGRASS	40%	85%	90%
LOLIUM PERENNE "PALMER"	PALMER PERENNIAL RYEGRASS	15%	95%	90%
FESTUCA RUBRA COMMUTATA WILMA	WILMA CHEWINGS	8%	95%	80%

- SEED TO BE SPREAD AT MINIMUM RATE OF 5 LBS. PER 1000 SQ. FT.
- SEEDING TO BE COMPLETED "IN SEASON" BETWEEN APRIL 1 TO JUNE 15 OR AUGUST 15 TO OCTOBER 1, EXCEPT FOR RESEEDING OF BARE SPOTS. IF UNABLE TO SEED WITHIN THESE TIMEFRAMES, CONTRACTOR TO INSTALL EROSION CONTROL MATS ON ALL SLOPES 3:1 AND OVER, HYDROSEED ALL EXPOSED AREAS, ADD SOIL STABILIZER "FLUX TERRA HP-FGM SOIL STABILIZER" AS MANUFACTURED BY "PROFILE" TO HYDROSEED (AT RATE OF 3,000 LBS PER ACRE), AT NO ADDITIONAL COST TO THE OWNER. CONTRACTOR TO COMPLETE ALL ABOVE "OUT OF SEASON" REQUIREMENTS AND THEN ALSO BE RESPONSIBLE FOR RE-GRADING AND RE-SEEDING ALL DISTURBED, ERODED, OR BARE SPOTS WITHIN NEXT CLOSEST PLANTING SEASON IN FALL OR SPRING AT NO ADDITIONAL COST TO OWNER. CONTRACTOR RESPONSIBLE FOR ALL MAINTENANCE UNTIL FINAL ACCEPTANCE OF LAWN AREAS INCLUDING: WATERING, ADDING FERTILIZERS AND LIME AND MOWING AT NO ADDITIONAL COST TO OWNER.
- COMMERCIAL FERTILIZER SHALL BE APPLIED AT THE RATE OF 25 POUNDS PER 1000 SQ. FT. OR AS RECOMMENDED BY THE TESTING AGENCY. LIME TO BE SPREAD AT THE RATE OF 100 POUNDS PER 1000 SQ. FT. OR AS RECOMMENDED BY THE TESTING AGENCY. COMMERCIAL FERTILIZER SHALL BE A COMPLETE FERTILIZER CONTAINING AT LEAST 50% OF THE NITROGEN OF WHICH IS DERIVED FROM NATURAL ORGANIZE SOURCES OF UREAFORM. IT SHALL CONTAIN THE FOLLOWING PERCENTAGES BY WEIGHT: NITROGEN (N) 10%, PHOSPHORUS (P) 6%, POTASH (K) 4%. LIME SHALL BE AN APPROVED AGRICULTURAL LIMESTONE CONTAINING NOT LESS THAN 85% OF TOTAL CARBONATES. LIMESTONE SHALL BE GROUND TO SUCH FINENESS THAT 50% WILL PASS A 100 MESH SIEVE AND 90% WILL PASS THROUGH A 20 MESH SIEVE.
- LAWN AREAS TO BE SEED BY SOWING EVENLY WITH AN APPROVED MECHANICAL SEEDER AT THE RATE OF TEN POUNDS PER 1000 SQUARE FEET.
- CONTRACTOR RESPONSIBLE FOR WATERING, MOWING, AND RESEEDING OF LAWN BARE SPOTS UNTIL A UNIFORM, HEALTHY STAND OF GRASS IS ESTABLISHED AND ACCEPTED.

**NOTES:**

- ALL SHRUBS SHALL HAVE THE SAME RELATIONSHIP TO FINISH GRADE AFTER PLANTING AS THEY HAD AT THE ORIGINAL NURSERY SETTING. SET SHRUB 1"-2" ABOVE FINISH GRADE.
- BACKFILL WITH PLANTING MIX. PLANT MIX TO BE: 50% NATIVE TOPSOIL, 20% COMPOST (LEAVES & ORGANIC MATERIAL, NO ASH) 20% PEAT MOSS, 10% SAND.
- ADD MYCORRHIZA SOIL ADDITIVES AND SLOW RELEASE FERTILIZER WHEN PLANT HOLES ARE 50% FILLED AND WATER THOROUGHLY AT COMPLETION.
- SHRUB BEDS TO HAVE 24" MIN. OF CONTINUOUS PLANTING SOIL.

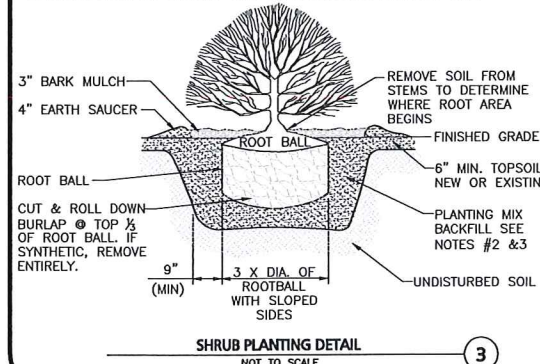

**SHRUB PLANTING DETAIL**  
 NOT TO SCALE

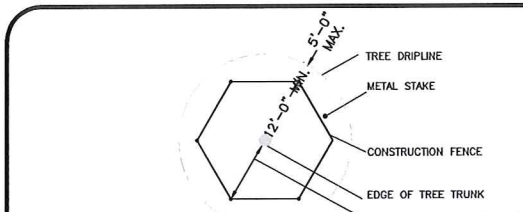

**NOTE:**

- CONSTRUCTION FENCE TO BE "VISUAL BARRIER FENCE" AS MANUFACTURED BY EXXON CHEMICAL COMPANY ATLANTA, GA; "KONTROL SAFETY FENCE" AS MANUFACTURED BY MIRAFI, CHARLOTTE, N.C. OR APPROVED EQUAL.
- IF GROUPS OF TREES ARE TO BE PROTECTED, EXTEND FENCE AROUND PERIMETER TO CONFORM TO MINIMUM DIMENSIONS FOR TREE TRUNKS AND DRIFLINE.

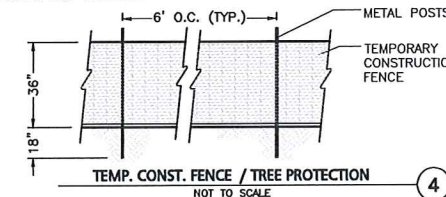

**TEMP. CONST. FENCE / TREE PROTECTION**  
 NOT TO SCALE

**SEED MIX:**

NEW ENGLAND WETLAND PLANTS  
 820 WEST STREET, AMHERST, MA 01002  
 PHONE: 413-548-8000 FAX 413-549-4000  
 EMAIL: INFO@NEWPC.COM WEB ADDRESS: WWW.NEWPC.COM

**NEW ENGLAND EROSION CONTROL/RESTORATION MIX FOR DRY SITES**

BOTANICAL NAME	COMMON NAME	WETLAND INDICATOR
ELYMUS CANADENSIS	CANADA WILD RYE	FACU+
FESTUCA RUBRA	RED FESCUE	FACU
LOLIUM MULTIFLORUM	ANNUAL RYEGRASS	
LOLIUM PERENNE	PERENNIAL RYEGRASS	
PANICUM VIRGATUM	SWITCH GRASS	FAC
SORGHASTRUM NUTANS	INDIAN GRASS	UPL
SCHIZACHYRIUM SCOPARIUM	LITTLE BLUESTEM	FACU
AGROSTIS PERENNANS	UPLAND BENTGRASS	FACU

THE NEW ENGLAND EROSION CONTROL/RESTORATION MIX FOR DRY SITES PROVIDES AN APPROPRIATE SELECTION OF NATIVE AND NATURALIZED GRASSES TO ENSURE THAT DRY AND RECENTLY DISTURBED SITES WILL BE QUICKLY REVEGETATED AND THE SOIL SURFACE STABILIZED. IT IS AN APPROPRIATE SEED MIX FOR ROAD CUTS, PIPELINES, STEEPER SLOPES, AND AREAS REQUIRING QUICK COVER DURING THE ECOLOGICAL RESTORATION PROCESS. THE MIX MAY BE APPLIED BY HYDRO-SEEDING, BY MECHANICAL SPREADER, OR ON SMALL SITES IT CAN BE SPREAD BY HAND. LIGHTLY RAKE, OR ROLL TO ENSURE PROPER SOIL-SEED CONTACT. BEST RESULTS ARE OBTAINED WITH A SPRING OR LATE SUMMER SEEDING. LATE SPRING THROUGH MID-SUMMER SEEDING WILL BENEFIT FROM A LIGHT MULCHING OF WEED-FREE STRAW TO CONSERVE MOISTURE. IF CONDITIONS ARE DRIER THAN USUAL, WATERING WILL BE REQUIRED. FERTILIZATION IS NOT REQUIRED UNLESS THE SOILS ARE PARTICULARLY INFERTILE. PREPARATION OF A CLEAN WEED FREE SEED BED IS NECESSARY FOR OPTIMAL RESULTS.

APPLY: 35 LBS/ACRE :1250 SQ FT/LB

EROSION CONTROL BLANKET FOR SLOPES SEE LANDSCAPE NOTES



REV	DATE	DESCRIPTION
1	04-04-23	REVISION 1 PER PEER REVIEW

APPLICANT/OWNER:  
**TMC HOLDINGS & DEVELOPMENT 2, LLC**  
 24 WILLIAM WAY  
 BELLINGHAM, MA 02019

PROJECT:  
**25 FORGE PARKWAY**  
 FRANKLIN, MA

PROJECT NO. 2712-02A DATE: 02-21-23

SCALE: AS SHOWN DWG. NAME: L-501

DESIGNED BY: SM/RLB CHECKED BY: BDJ



**ALLEN & MAJOR ASSOCIATES, INC.**  
 civil engineering • land surveying  
 environmental consulting • landscape architecture  
 www.allenmajor.com  
 100 COMMERCE WAY, SUITE 5  
 WOBURN, MA 01801  
 TEL: (781) 935-6889  
 FAX: (781) 935-2896

WOBURN, MA • LAKEVILLE, MA • MANCHESTER, NH  
 THIS DRAWING HAS BEEN PREPARED IN DIGITAL FORMAT. CLIENTS/CLIENTS REPRESENTATIVE OR CONSULTANTS MAY BE PROVIDED COPIES OF DRAWINGS AND SPECIFICATIONS FOR HIS/HER INFORMATION AND/OR SPECIFIC USE ON THIS PROJECT. DUE TO THE POTENTIAL THAT THE PROVIDED INFORMATION MAY BE MODIFIED UNINTENTIONALLY OR OTHERWISE, ALLEN & MAJOR ASSOCIATES, INC. MAY REMOVE ALL INDICATION OF THE DOCUMENTS AUTHORSHIP ON THE DIGITAL MEDIA. PRINTED REPRESENTATIONS OR PORTABLE DOCUMENT FORMAT OF THE DRAWINGS AND SPECIFICATIONS ISSUED SHALL BE THE ONLY RECORD COPIES OF ALLEN & MAJOR ASSOCIATES, INC.'S WORK PRODUCT.

DRAWING TITLE: LANDSCAPE NOTES & DETAILS SHEET NO. L-501  
 Copyright © 2023 Allen & Major Associates, Inc. All Rights Reserved.