

**DESIGN REVIEW COMMISSION
AGENDA**

June 27, 2023

7:00 PM

Virtual Meeting

Due to the growing concerns regarding the COVID-19 virus, we will be conducting a remote/virtual Design Review Commission Meeting. In an effort to ensure citizen engagement and comply with open meeting law regulations, citizens will be able to dial into the meeting using the provided phone number (Cell phone or Landline Required) OR citizens can participate by copying the link (Phone, Computer, or Tablet required). Please click on <https://us02web.zoom.us/j/81608724484> or call on your phone at 1-929-205-6099, meeting ID is 81608724484

7:00 PM Taco Bell – 420 West Central Street
Replace existing menu board with electronic menu board

7:01 PM Cat’s Healing Corner, LLC – 247 East Central Street
Three signs: Window, Door, Parking

General Matters:

Approval of Minutes: June 13, 2023

Old Business:

New Business:

Adjourn

COMMENTS: These listing of matters are those reasonably anticipated by the Chair which may be discussed at the meeting. Not all items listed may in fact be discussed and other items not listed may also be brought up for discussion to the extent permitted by law. This agenda is subject to change. Next meeting is 7/11/2023

FORM Q

TOWN OF FRANKLIN
DESIGN REVIEW APPLICATION
FOR §185-31(2) OF THE ZONING BY-LAW

A) General Information

Name of Business or Project: TACO BELL

Property Address 420 WEST CENTRAL STREET

Assessors' Map # 270 Parcel # 001

Zoning District (select applicable zone): BUSINESS

Zoning History: Use Variance _____
Non-Conforming Use _____

B) Applicant Information:

Applicant Name: SIGNATURE SIGNS C/O ADAM

Address: 833 AMERICAN LEGION HIGHWAY
WESTPORT MA. 02790

Telephone Number: 774.309.3307

Contact Person: ADAM ABDELHA

C) Owner Information (Business Owner & Property Owner if different)

Business Owner: DESERT DESIRO FOODS
TACO BELL Property Owner: MARGARET RANIERI
Address: 79 NORTH MAIN STREET RANIERI TRUST
MANFIELD, MA. 02048

All of the information is submitted according to the best of my knowledge
Executed as a sealed instrument this 13TH day of JUNE 2023

Adam F. Abdelha Signature
Signature of Applicant

SEE ATTACHED AUTHORIZATION
Signature of Owner

ADAM F. ABDELHA
Print name of Applicant

Print name of Owner

*FOR SIGNS COMPLETE PAGES 1 & 2 ONLY.
FOR SITE PLANS, BUILDING PLANS, PROJECTS, COMPLETE PAGES 1 - 4

SEE ADDENDA ATTACHED FOR ASSISTANCE IN COMPLETION OF FORM Q

D) Architect/Engineer/Sign Company Information (if not the applicant)

a. Sign Company

Business Name: SIGNATURE SIGNS
Contact Person: ADAM ABELHA
Address 833 AMERICAN LEGION HIGHWAY WESTPORT MA. 02790
Telephone Number: 774.309.3307

b. Architect/Engineer (when applicable)

Business Name: _____
Contact Person: N/A
Address _____
Telephone Number: _____

E) Work Summary

Summary of work to be done: REPLACE EXISTING MENU BOARD AT TACO BELL W/ ELECTRONIC MENU BOARD, UTILIZING THE SAME BASE FOUNDATION & UPRIKING OF EXISTING. SEE ATTACHED RENDERINGS. EXISTING IS LIGHTED BOX W/ STATIC CONTENT. NEW IS TV MONITOR MENU SCREEN

F) Information & Materials to be Submitted with Application

a) FOR SIGN SUBMISSIONS ONLY:

THE FOLLOWING MUST BE SUBMITTED ELECTRONICALLY TO Mkinhart@franklinma.gov

1. Drawing of Proposed Sign which must also include
type of sign (wall, pylon etc.) colors
size/dimensions materials
style of lettering lighting-illuminated, non-illuminated and style
2. Drawing and/or pictures indicating location of new sign.
3. Picture of existing location and signs (if previously existing location)

b) FOR BUILDINGS/DEVELOPMENTS OR PROJECT SUBMISSIONS:

THE FOLLOWING MUST BE SUBMITTED W/APPLICATION to Mkinhart@franklinma.gov

1. Site Plan including Landscape Plan showing plantings. Plantings must be from Best Development Practices Guide
2. Lighting Plan indicating lighting levels & specifications of proposed lights
3. Building drawings, indicating size and height of building(s); front, rear and side elevations (when there are no adjoining buildings) and floor plans
4. Drawings or pictures of existing conditions
5. If any signage on the building or site, provide information from above Signage Checklist

**PROPERTY OWNER/LANDLORD
PERMISSION DOCUMENTATION**

I have authorized Signature Signs and their staff to submit and obtain all permits required from the city/town for the installation of a sign(s) at the location listed below.

1 one (1) digital menu board
@ Taco Bell, 420 West Central St., Franklin MA 02038

mailing

PROPERTY OWNER:
PROPERTY OWNER'S NAME: Margaret C. Ranieri TR., Ranieri Trust
STREET ADDRESS: P.O. Box Q
CITY/STATE/ZIP: Franklin MA 02038
PHONE NUMBER: 508.628.0930
EMAIL ADDRESS: office@RanieriRE.com
SIGNATURE: MCRanieri
DATE: 6.8.2023

BUSINESS APPLYING FOR SIGN PERMIT:
BUSINESS NAME: TACO BELL
STREET ADDRESS: 420 WEST CENTRAL ST.
CITY/STATE/ZIP: FRANKLIN, MA. 02038
BUSINESS OWNER'S NAME: DESERE DE ORO FODOS
PHONE NUMBER: 508.452.9459
EMAIL: MARKRAYMOND@DOROFODOS.COM
SIGNATURE: MJR
DATE: 6.8.23



**TACO
BELL™**

420 West Central Street, Franklin, MA

Current Date: 3/6/2023



833 American Legion Hwy.
Westport, MA 02790
mysigns@msn.com | 774-309-3307

Customer Proof:



current menu board
static menu in light box



proposed
digital menu board

Remove existing menu board
Replace with new menu board
Use same foundation - bolt system



833 American Legion Hwy.
Westport, MA 02790
mysigns@msn.com | 774-309-3307

Menuboard Replacement / Refurbish Stratacache V12MP Double

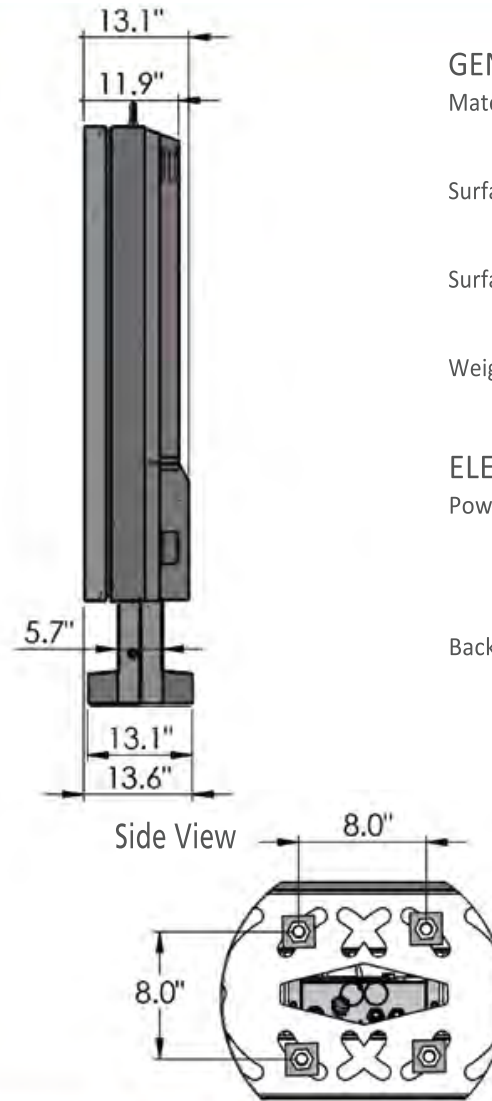
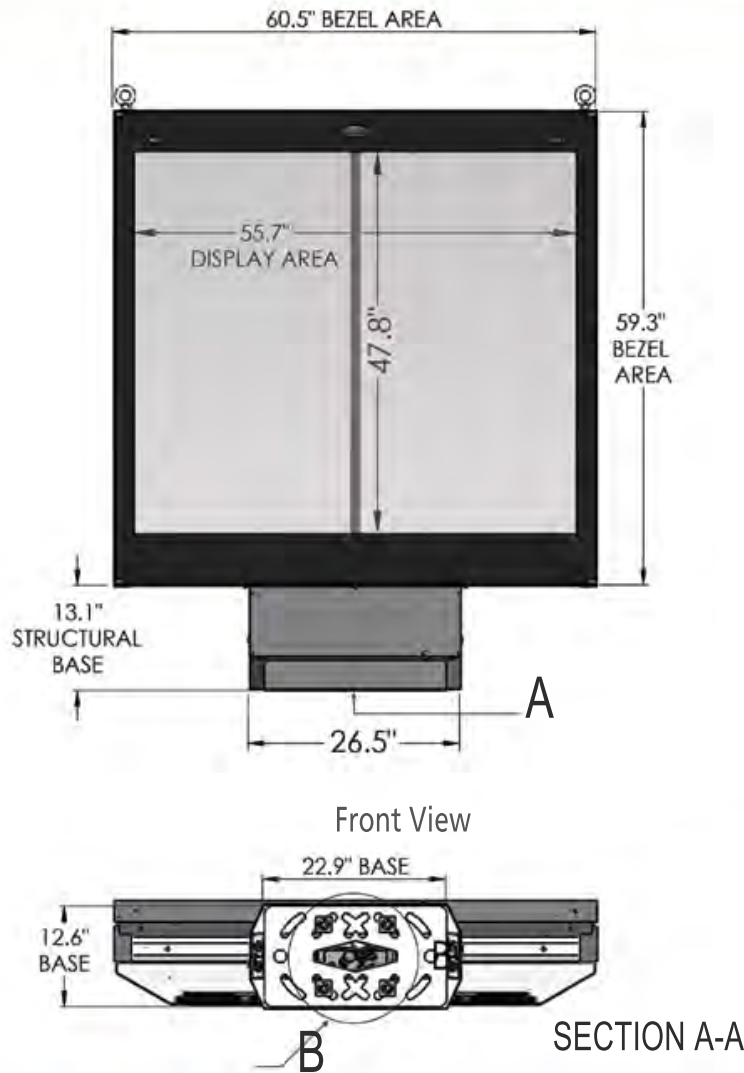

GENERAL SPECS

Material: Aluminum exterior with tube steel inner frame.
Certified 180 MPH

Surface Treatment:
- Pretreatment - zinc primer & polyester powder coating

Surface Area:
- Display: 18.5 sq/ft
- Total surface: 24.9 sq/ft

Weight:
- Gross: 915 lbs / Net: 705 lbs

ELECTRICAL SPECS

Power:
- Hardwired AC Power
- 120/240V 50/60Hz
- 1150 W (@ max load)
- UL Rated @ 10 Amp

Backlight:
- LED Light Source
- 380 CD/M2 to 3,500 CD/M2
- Auto adjusting to outdoor ambient light levels



833 American Legion Hwy.
Westport, MA 02790
mysigns@msn.com | 774-309-3307

Current Date: 3/6/2023

FORM Q

TOWN OF FRANKLIN
DESIGN REVIEW APPLICATION
FOR §185-31(2) OF THE ZONING BY-LAW

A) General Information

Name of Business or Project: Car's Healing corner, LLC

Property Address 247 East Central St Franklin

Assessors' Map # 285 Parcel # 285-105-000-008

Zoning District (select applicable zone): Commercial 2 (TWB)

Zoning History: Use Variance Spoke w/ town and clerk
Non-Conforming Use was unsure

B) Applicant Information:

Applicant Name: Cathy Brown

Address: 21 Seekonk St Norfolk, MA

Telephone Number: 508 965 1469

Contact Person: Cathy Brown

C) Owner Information (Business Owner & Property Owner if different)

Business Owner: Cathy Brown Property Owner: Diane Padula, Trustee
Address: 247 E Central St Franklin, MA 247 E. Central Street R.T.

All of the information is submitted according to the best of my knowledge

Executed as a sealed instrument this _____ day of _____ 20____

Catherine Brown

Signature of Applicant

Diane M. Padula

Signature of Owner

Catherine Brown

Print name of Applicant

Diane M. Padula

Print name of Owner

***FOR SIGNS COMPLETE PAGES 1 & 2 ONLY.**

FOR SITE PLANS, BUILDING PLANS, PROJECTS, COMPLETE PAGES 1 - 4

SEE ADDENDA ATTACHED FOR ASSISTANCE IN COMPLETION OF FORM Q

D) Architect/Engineer/Sign Company Information (if not the applicant)

a. Sign Company

Business Name: N/A
Contact Person: _____
Address _____
Telephone Number: _____

b. Architect/Engineer (when applicable)

Business Name: _____
Contact Person: N/A
Address _____
Telephone Number: _____

E) Work Summary

Summary of work to be done: N/A

F) Information & Materials to be Submitted with Application

a) FOR SIGN SUBMISSIONS ONLY:

**THE FOLLOWING MUST BE SUBMITTED ELECTRONICALLY TO
Mkinhart@franklinma.gov**

1. Drawing of Proposed Sign which must also include
type of sign (wall, pylon etc.) colors
size/dimensions materials
style of lettering lighting-illuminated, non-illuminated and style
2. Drawing and/or pictures indicating location of new sign.
3. Picture of existing location and signs (if previously existing location)

b) FOR BUILDINGS/DEVELOPMENTS OR PROJECT SUBMISSIONS:

THE FOLLOWING MUST BE SUBMITTED W/APPLICATION to Mkinhart@franklinma.gov

1. Site Plan including Landscape Plan showing plantings. Plantings must be from Best Development Practices Guide
2. Lighting Plan indicating lighting levels & specifications of proposed lights
3. Building drawings, indicating size and height of building(s); front, rear and side elevations (when there are no adjoining buildings) and floor plans
4. Drawings or pictures of existing conditions
5. If any signage on the building or site, provide information from above Signage Checklist

SIGN MEASUREMENTS

247 E Central St

Franklin

3 SIGNS

Large window

Dimensions

52" x 47"

The sign size will be 18" X 12"

Door Dimensions 6' x 30'

The sign will be 18" x 24"

Parking sign

18" x 12"



CAT'S HEALING CORNER, LLC

A MODERN GIFT STORE

(508) 965-1469

STICKER FOR

windows / DOOR



CAT'S HEALING CORNER, LLC

(508) 965-1469

PARKING SIGN
OUTSIDE

CAVE
OP
barbershop.com

ROYAL
CAVE
BARBERSHOP

royalcavebarbershop.com



Mobil

Padula &
Associates, P.C.
**PARKING
ONLY**



ESG

247



PADULA
INSURANCE

PADULA & ASSOCIATES, P.C.

ATTORNEYS AT LAW

Town of Franklin



Design Review Commission

Tuesday, June 13, 2023
Meeting Minutes

Chair James Bartro called the above-captioned meeting to order this date at 7:00 PM, as a remote access virtual Zoom meeting. Members in attendance: Chair James Bartro, Vice Chair Sam Williams, Gerald Wood, Cassandra Bethoney. Members absent: Paul Lopez, Associate Chris Baryluk. Also present: Maxine Kinhart, Administrative Staff.

As stated on the agenda, due to the continued concerns regarding the COVID-19 virus, this meeting will be conducted as a remote/virtual Design Review Commission meeting. In an effort to ensure citizen engagement and comply with open meeting law regulations, citizens will be able to dial into the meeting using the provided phone number, or citizens can participate by using the Zoom link provided on the agenda. This meeting was recorded.

1. Union Street Wine & Liquor – 317 Union Street – Replace existing sign box with channel letters.

Ms. Danielle Silva of Best Price Signs and Printing stated that it will be the existing sign box with a new face, the channel letters will be installed onto the face, and it will be slid right into that existing box. She confirmed that it is a non-illuminated backdrop. She confirmed that the letters will be illuminated. She stated that the size is 12 ft. x 2 ft. She confirmed that she is not touching the pylon at this time.

Motion: To **Approve** the sign package as submitted. Motioned by S. Williams. Seconded by G. Wood. Roll Call Vote: Williams-YES; Wood-YES; Bethoney-YES; Bartro-YES. Voted 4-0-0.

GENERAL MATTERS

Approval of Minutes: May 9, 2023

Motion: To **Approve** the May 9, 2023 Meeting Minutes as presented. Motioned by S. Williams. Seconded by J. Bartro. Roll Call Vote: Williams-YES; Wood-YES; Bethoney-ABSTAIN; Bartro-YES. Voted 3-0-1.

Old Business

Chair Bartro stated the he announced at the last meeting that he is going to be stepping back as chair of the commission. He stated that he has decided to stay on the commission as an associate member. He stated that this will take effect after the next meeting. He stated that he is encouraging the current vice chair to take over as chair of the commission.

New Business

Chair Bartro stated that Gerald Wood, after many years of loyal service to the commission, has decided not to renew his seat on this commission. He stated that on behalf of the Town of Franklin, thank you very much for your service to this commission. Mr. Wood stated this has been a great experience.

Motion: To **Adjourn** by S. Williams. Seconded by G. Wood. Roll Call Vote: Williams-YES; Wood-YES; Bethoney-YES; Bartro-YES. Voted 4-0-0.

Meeting adjourned at 7:10 PM.

Respectfully submitted,

Judith Lizardi
Recording Secretary