

DESIGN REVIEW COMMISSION

AGENDA

April 26, 2022
7:00 PM

Virtual Meeting

Due to the growing concerns regarding the COVID-19 virus, we will be conducting a remote/virtual Design Review Commission Meeting. In an effort to ensure citizen engagement and comply with open meeting law regulations, citizens will be able to dial into the meeting using the provided phone number (Cell phone or Landline Required) OR citizens can participate by copying the link (Phone, Computer, or Tablet required). Please click on <https://us02web.zoom.us/j/82456126304> or call on your phone at 1-929-205-6099, meeting ID is 82456126304

- 7:00 PM Smiley Gas and Convenience – 52 East Central Street**
Rebranding gas station signage from Gulf and DBMart to Smiley Gas & Convenience - **Motion to Remove from Table**
- 7:01 PM NISSHA Metallizing Solutions – 17 National Drive**
Install one non-illuminated sign – **Motion to Remove from Table**
- 7:02 PM NISSHA Metallizing Solutions – 24 National Drive**
Install one non-illuminated sign – **Motion to Remove from Table**
- 7:03 PM Physicianone Urgent Care – 648 Old West Central Street**
Remove existing signage, install new signage
- 7:04 PM Prospect Hill Country Day School – 54 Prospect Street**
Replacement sign 53” x 48” PVC ¾ with color print and overlay PT wood Posts, and PVC post covers

General Matters:

Approval of Minutes: April 12, 2022

COMMENTS: These listing of matters are those reasonably anticipated by the Chair which may be discussed at the meeting. Not all items listed may in fact be discussed and other items not listed may also be brought up for discussion to the extent permitted by law. This agenda is subject to change. Last updated: 4-21-2022 Next meeting is 5/10/2022

FORM Q

TOWN OF FRANKLIN
DESIGN REVIEW APPLICATION
FOR §185-31(2) OF THE ZONING BY-LAW

A) General Information

Name of Business or Project: SMILEY GAS AND CONVENIENCE

Property Address 52 E. CENTRAL STREET

Assessors' Map # 286 Parcel # 37

Zoning District (select applicable zone): DOWNTOWN COMERCIAL DISTRICT

Zoning History: Use Variance _____
Non-Conforming Use _____

B) Applicant Information:

Applicant Name: 52 E. CENTRAL ST. LLC. (NABIL NAKHOUL, MANAGER)

Address: 1 IRONGATE DR.
FRANKLIN MA 02038

Telephone Number: (617) 504-5364

Contact Person: NABIL NAKHOUL

C) Owner Information (Business Owner & Property Owner if different)

Business Owner: _____ Property Owner: _____

Address: _____

All of the information is submitted according to the best of my knowledge

Executed as a sealed instrument this _____ day of _____ 20____

[Signature]

Signature of Applicant

[Signature]

Signature of Owner

NABIL NAKHOUL

Print name of Applicant

NABIL NAKHOUL

Print name of Owner

Hotmail.com

*FOR SIGNS COMPLETE PAGES 1 & 2 ONLY.

FOR SITE PLANS, BUILDING PLANS, PROJECTS, COMPLETE PAGES 1 - 4

SEE ADDENDA ATTACHED FOR ASSISTANCE IN COMPLETION OF FORM Q

mkinhart@franklinma.gov

D) Architect/Engineer/Sign Company Information (if not the applicant)

a. Sign Company

Business Name: N.H. SIGNS

Contact Person: MARK LIRMAN

Address 66 GOLD LEDGE AVE.

Telephone Number: (603) 437-1200

b. Architect/Engineer (when applicable)

Business Name: _____

Contact Person: _____

Address _____

Telephone Number: _____

E) Work Summary

Summary of work to be done: REBRANDING THE GAS STATION
SIGNAGE FROM GULF AND DB MART
TO SMILEY GAS & CONVENIENCE.

F) Information & Materials to be Submitted with Application

a) FOR SIGN SUBMISSIONS ONLY:

NINE (9) COPIES OF THE FOLLOWING MUST BE SUBMITTED WITH APPLICATION

1. Drawing of Proposed Sign which must also include
type of sign (wall, pylon etc.) colors
size/dimensions materials
style of lettering lighting-illuminated, non-illuminated and style
2. Drawing and/or pictures indicating location of new sign.
3. Picture of existing location and signs (if previously existing location)

b) FOR BUILDINGS/DEVELOPMENTS OR PROJECT SUBMISSIONS:

NINE (9) COPIES OF THE FOLLOWING MUST BE SUBMITTED W/APPLICATION

1. Site Plan including Landscape Plan showing plantings. Plantings must be from Best Development Practices Guide
2. Lighting Plan indicating lighting levels & specifications of proposed lights
3. Building drawings, indicating size and height of building(s); front, rear and side elevations (when there are no adjoining buildings) and floor plans
4. Drawings or pictures of existing conditions
5. If any signage on the building or site, provide information from above Signage Checklist

Note: Please bring a sample of the following to the meeting: materials samples (brick, siding, roofing etc.) as well as samples of paint colors.

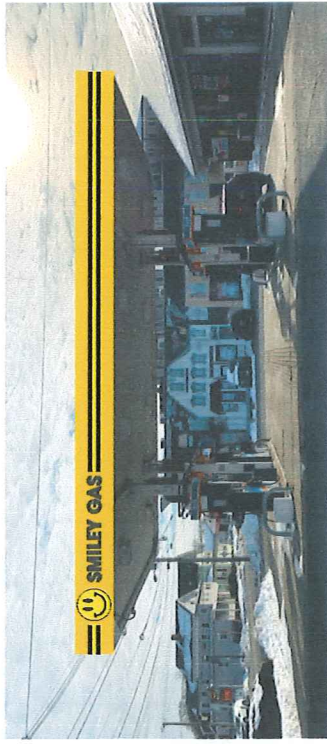
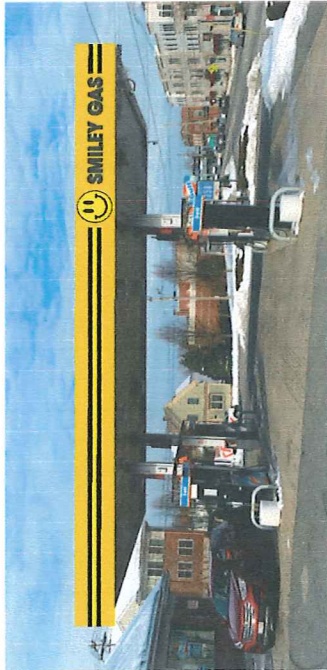

NO CHANGE IN CANOPY SIZE

49'



CUT VINYL GRAPHICS



TRAFFIC YELLOW ALUCOBOND

TRAFFIC YELLOW ALUCOBOND



TRAFFIC YELLOW ALUCOBOND



TRAFFIC YELLOW ALUCOBOND

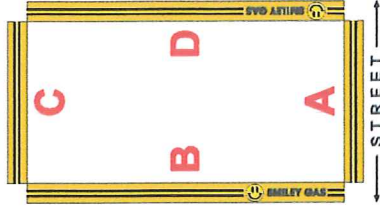

 SERVING NEW ENGLAND SINCE 1992
 DESIGN = MANUFACTURE = INSTALL = SERVICE
nhsigns.com = 603.437.1200
 66 Gold Ledge Avenue, Auburn, NH 03032
 FAX 603.437.1222

CLIENT: SMILEY GAS
LOCATION: FRANKLIN, MA
DATE: 3.4.22

DESIGNER: J. Saville
 ACCT. REP: M. Libon

DESIGN APPROVED BY _____ DATE / / 16

MORE INFORMATION IS REQUIRED
 SURVEY NEEDED FOR: []
 FINAL DRAWING []
 AND PRICING []
 PERIOD PRODUCTION []

PLEASE MAKE SURE THE MANUFACTURER HAS ALL THE INFORMATION NEEDED TO PRODUCE THE SIGN. THIS INCLUDES:

PHOTOGRAPH OF THE LOCATION
 PHOTOGRAPH OF THE SIGNAGE
 PHOTOGRAPH OF THE SIGNAGE
 PHOTOGRAPH OF THE SIGNAGE
 PHOTOGRAPH OF THE SIGNAGE

 66 Gold Ledge Avenue Auburn, NH 03032 603-437-1200 FAX 603-437-1223 www.nhsigns.com		DESIGN MANUFACTURE INSTALL SERVICE	CLIENT: SMILEY GAS	LOCATION: FRANKLIN, MA	DATE: 3.7.22
ACCT. REP	M. Libsorn	DESIGN	J. Sanville	DATE:	0.0.22
REV. NOTES	3.17.22 3.24.22 4.4.22				
<input checked="" type="checkbox"/> DESIGN APPROVED BY _____ DATE _____					
<small> I HAVE READ AND UNDERSTAND THE TERMS AND CONDITIONS OF THIS CONTRACT AND I AGREE TO BE BOUND BY THEM. I HAVE READ AND UNDERSTAND THE TERMS AND CONDITIONS OF THIS CONTRACT AND I AGREE TO BE BOUND BY THEM. I HAVE READ AND UNDERSTAND THE TERMS AND CONDITIONS OF THIS CONTRACT AND I AGREE TO BE BOUND BY THEM. </small>					

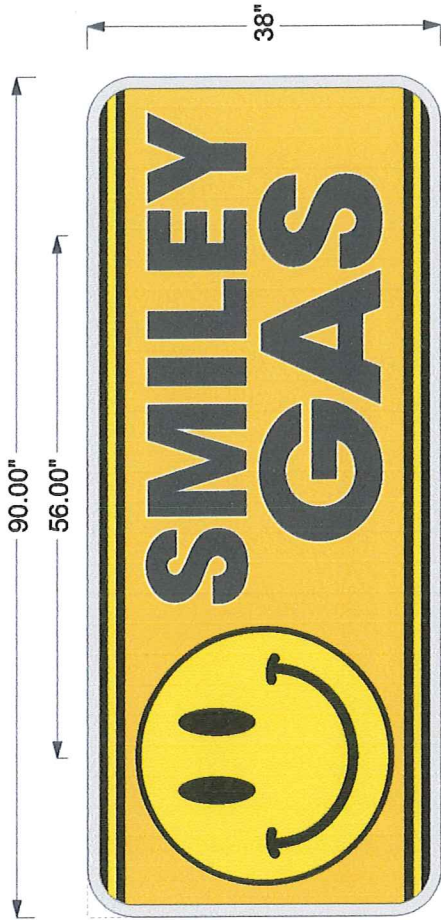

CUT RADIUS ON SITE



REFACE EXISTING D/S INTERNALLY ILLUMINATED MID.
 REMOVE PANS AND REPLACE WITH FLAT LEXAN LENSES.
 ADD 1 (PER SIDE) 18" DAKTRONICS UNIT

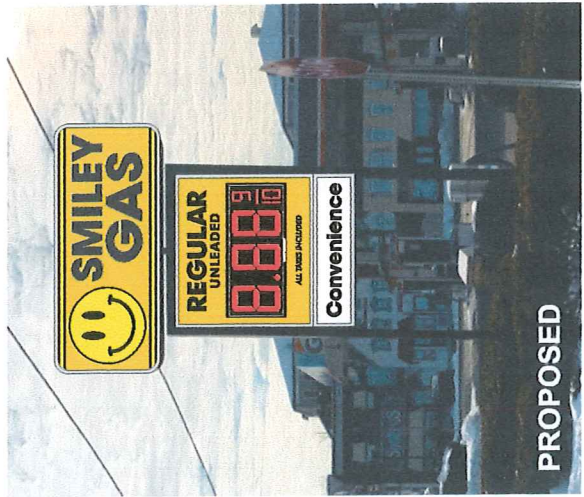

NO CHANGE IN SIGN SIZE



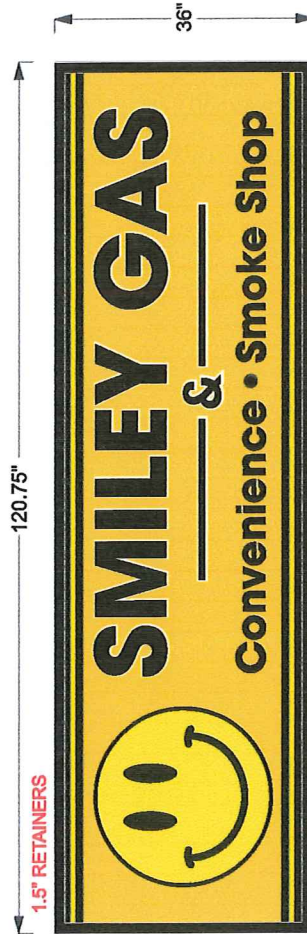
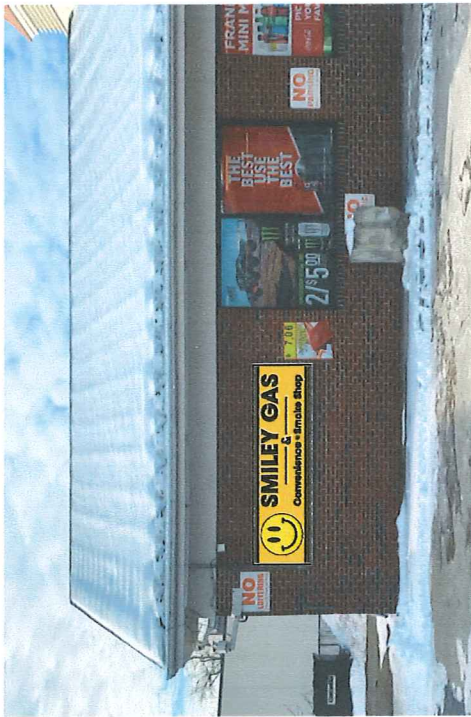

REFACE EXISTING S/S INTERNALLY ILLUMINATED WALL SIGN

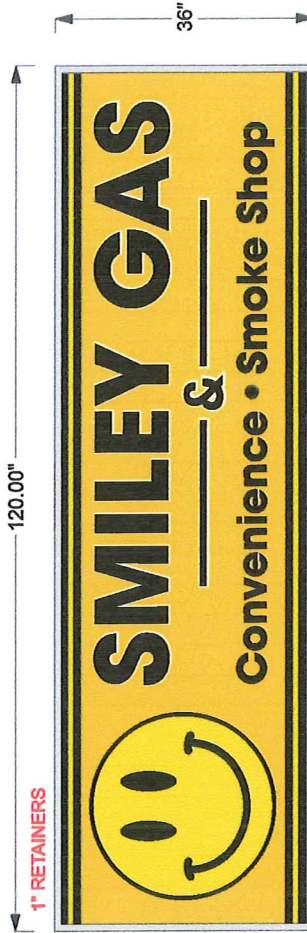
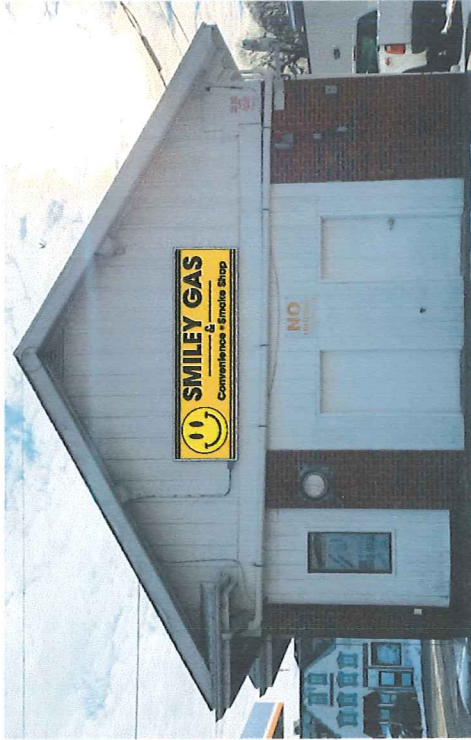

REFACE EXISTING S/S INTERNALLY ILLUMINATED WALL SIGN



DESIGN = MANUFACTURE = INSTALL = SERVICE
nhsigns.com = 603.437.1200
 66 Gold Ledge Avenue, Auburn, NH 03032
 FAX: 603.437.1222

CLIENT: SMILEY GAS
 LOCATION: FRANKLIN, MA
 DATE: 3-7-22
 DESIGNER: J. Saville
 ACT. REP: M. Libbon

REVISION	NOTES	BY	TYPE
1	3.17.22		
2	4.4.22		
3			

MORE INFORMATION REQUIRED
 SURVEY NEEDED FOR:
 FIELD MEASURING
 PERITS / PRODUCTION
 © INDIANA ILLUMINATIONS
 NHSIGNS OWNS THE COPYRIGHT ON ALL ORIGINAL DESIGNS.
 NHSIGNS HAS RECEIVED PATENT PROTECTION FOR ITS SIGNS.



PROPOSED

WILL NEED EXACT VALLENCE SIZE PRIOR TO PRODUCTION

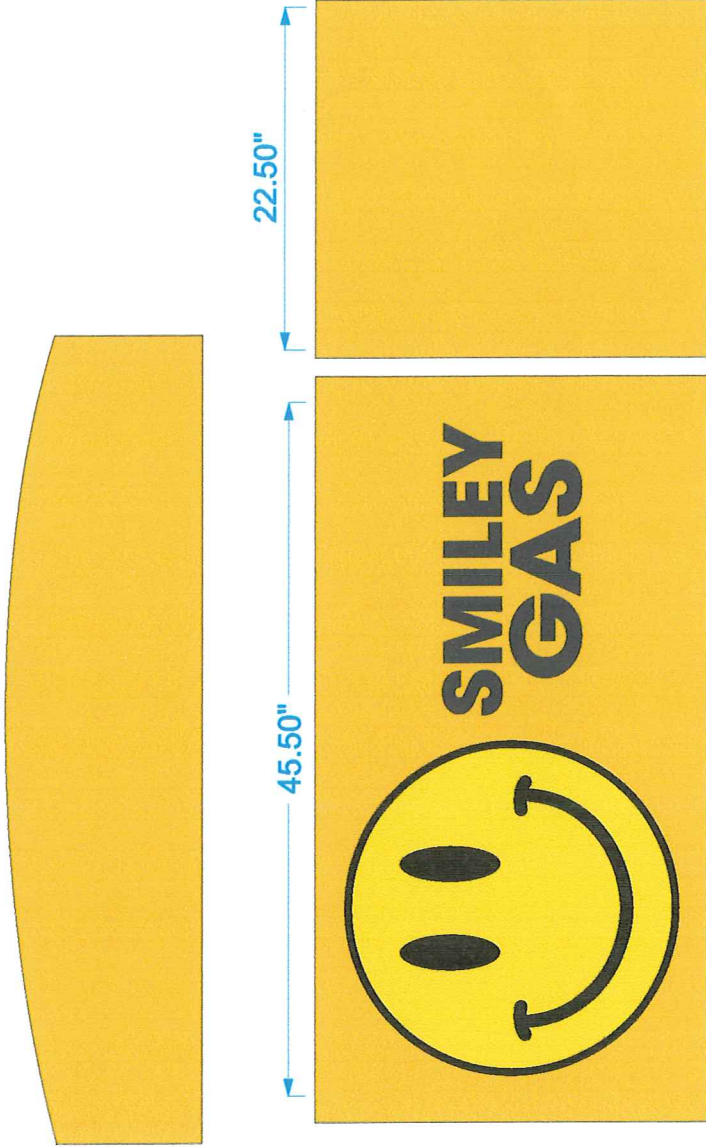

Apply new Dispenser Graphics.

● PMS 142

PCS FOR SIDES

66 Gold Ledge Avenue, Auburn, NH 03032 603 4371200 FAX: 603 437 1233 www.nhsigns.com	
<input type="checkbox"/> DESIGN <input type="checkbox"/> MANUFACTURE <input type="checkbox"/> INSTALL <input type="checkbox"/> SERVICE	<input type="checkbox"/> SIGNAGE <input type="checkbox"/> LETTERS <input type="checkbox"/> BANNERS
CLIENT:	SMILEY GAS
LOCATION:	FRANKLIN, MA
DATE:	3.7.22
ACCT. REP	M. Libsom
DESIGN	J. Sanville
DATE:	0.0.22
REV. NOTES	3.17.22 3.24.22 0.0.22
<input checked="" type="checkbox"/> DESIGN APPROVED	BY _____ DATE _____
<input type="checkbox"/> ACCEPT APPROVAL FOR PRODUCTION <input type="checkbox"/> VERIFY ALL INFORMATION <input type="checkbox"/> ALL INFORMATION IS CORRECT <input type="checkbox"/> ALL INFORMATION IS COMPLETE <input type="checkbox"/> ALL INFORMATION IS ACCURATE <input type="checkbox"/> ALL INFORMATION IS UP TO DATE <input type="checkbox"/> ALL INFORMATION IS CORRECT	
<input type="checkbox"/> ALL INFORMATION IS CORRECT <input type="checkbox"/> ALL INFORMATION IS COMPLETE <input type="checkbox"/> ALL INFORMATION IS ACCURATE <input type="checkbox"/> ALL INFORMATION IS UP TO DATE <input type="checkbox"/> ALL INFORMATION IS CORRECT	

FORM Q

TOWN OF FRANKLIN
DESIGN REVIEW APPLICATION
FOR §185-31(2) OF THE ZONING BY-LAW

A) General Information

Name of Business or Project: HISSTA METALLIZING SOLUTIONS

Property Address 17 NATIONAL DR

Assessors' Map # 290 Parcel # 602

Zoning District (select applicable zone): I

Zoning History: Use Variance _____
Non-Conforming Use _____

B) Applicant Information:

Applicant Name: SUNSHINE SIGN CO INC

Address: 121 WESTBOND RD
GROTON MA 01536

Telephone Number: 508 868 5401

Contact Person: William Kueck

C) Owner Information (Business Owner & Property Owner if different)

Business Owner: HISSTA METALLIZING Property Owner: 17 FINGER PARKWAY LLC
Address: 17 NATIONAL DR 113 TURNPIKE RD
FRANKLIN MA WESTBOND MA

All of the information is submitted according to the best of my knowledge
Executed as a sealed instrument this _____ day of _____ 20____

[Signature]
Signature of Applicant

See Attached
Signature of Owner

Wm Kueck Agent
Print name of Applicant

Print name of Owner

***FOR SIGNS COMPLETE PAGES 1 & 2 ONLY.
FOR SITE PLANS, BUILDING PLANS, PROJECTS, COMPLETE PAGES 1 - 4**

SEE ADDENDA ATTACHED FOR ASSISTANCE IN COMPLETION OF FORM Q

D) Architect/Engineer/Sign Company Information (if not the applicant)

a. Sign Company

Business Name: _____

Contact Person: _____

Address _____

Telephone Number: _____

b. Architect/Engineer (when applicable)

Business Name: _____

Contact Person: _____

Address _____

Telephone Number: _____

E) Work Summary

Summary of work to be done: Install only 96.14 SF Non Illuminated
Wall Sign

F) Information & Materials to be Submitted with Application

a) FOR SIGN SUBMISSIONS ONLY:

**THE FOLLOWING MUST BE SUBMITTED ELECTRONICALLY TO
Mkinhart@franklinma.gov**

1. Drawing of Proposed Sign which must also include
type of sign (wall, pylon etc.) colors
size/dimensions materials
style of lettering lighting-illuminated, non-illuminated and style
2. Drawing and/or pictures indicating location of new sign.
3. Picture of existing location and signs (if previously existing location)

b) FOR BUILDINGS/DEVELOPMENTS OR PROJECT SUBMISSIONS:

THE FOLLOWING MUST BE SUBMITTED W/APPLICATION to Mkinhart@franklinma.gov

1. Site Plan including Landscape Plan showing plantings. Plantings must be from Best Development Practices Guide
2. Lighting Plan indicating lighting levels & specifications of proposed lights
3. Building drawings, indicating size and height of building(s); front, rear and side elevations (when there are no adjoining buildings) and floor plans
4. Drawings or pictures of existing conditions
5. If any signage on the building or site, provide information from above Signage Checklist

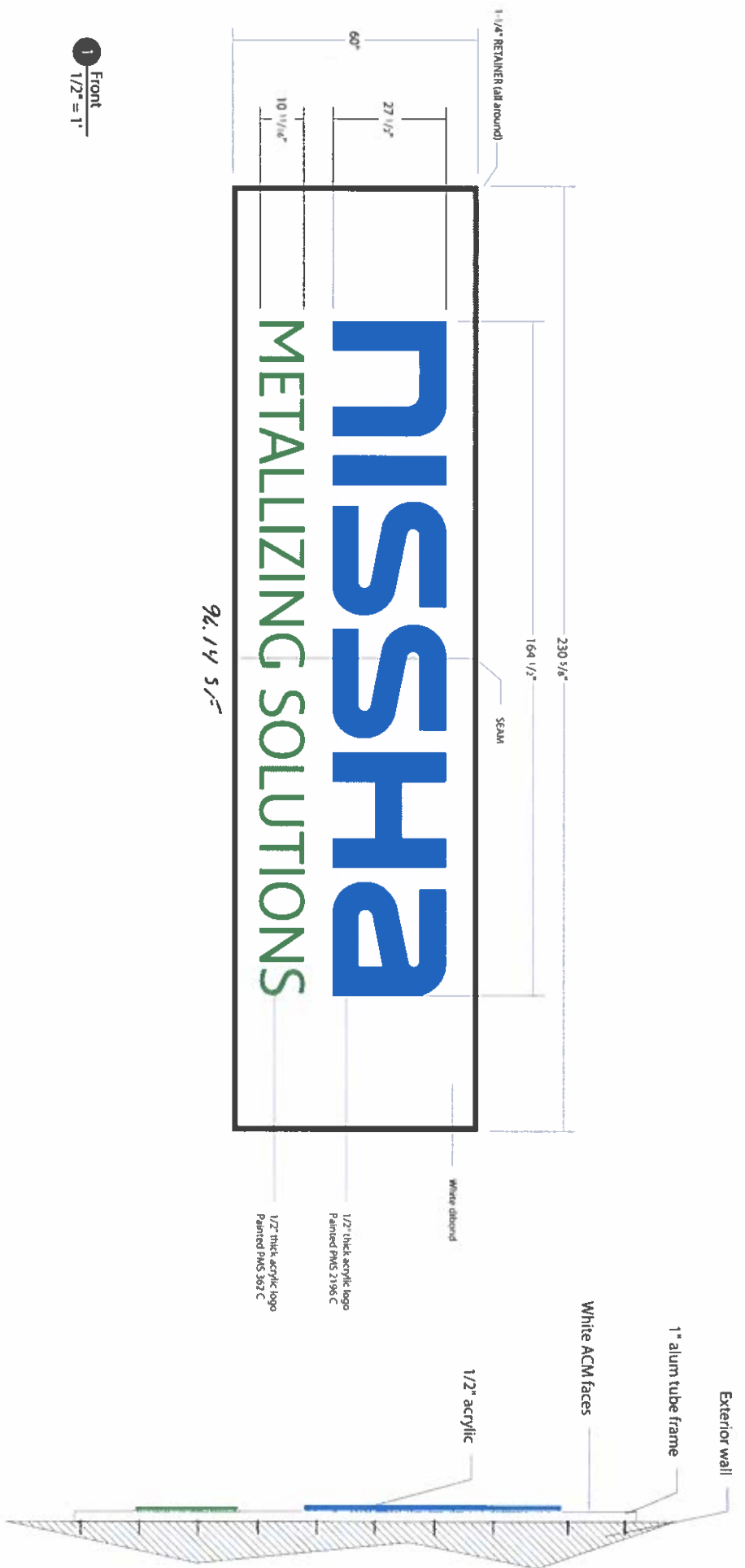

SIGN TYPE **D**

FAST sign

Quantity (1)

1" deep FAST sign with aluminum tube frame & prefinished white ACM faces. 1/2" thick painted acrylic logo mechanically fastened to face.

Palette

PAINT: PMS 2196 C

PAINT: PMS 362 C

CLIENT: AR METALLIZING (NISSHA)

PROJECT / SIGN TYPE: REBRAND

DRAWN BY: JG

JOB #: 17997-68185

DATE: 3/25/22

SUNSHINE sign

121 Westboro Road
 North Grafton, MA 01536
 P 508.839.5588
 F 508.839.9929
 www.sunshinesign.com

This drawing is given in confidence and may not be used or disseminated in any way without prior written consent from Sunshine Sign Company, Inc. All common law and copyright laws are hereby specifically reserved.

- Approved for Fabrication
- Approved as Noted
- Revise and Resubmit
- Rejected

Name _____
 Signature _____

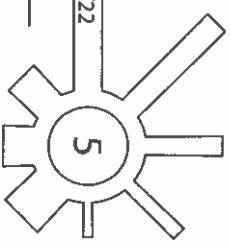

SIGN TYPE: D



17 Forge Park

CLIENT: AR METALLIZING (NISSHA)

PROJECT / SIGN TYPE: REBRAND

DRAWN BY: JG

JOB #: 17997-68185

DATE: 3/25/22

SUNSHINE
SIGN

121 Westboro Road
North Grafton, MA 01536
P 508.839.5588
F 508.839.9929
www.sunshinesign.com

This drawing is given in confidence and may not be used or disseminated in any way without prior written consent from Sunshine Sign Company, Inc. All common law and copyright laws are hereby specifically reserved.

- Approved for Fabrication
 Approved as Noted
 Revise and Resubmit
 Rejected

Name _____
Signature _____

SIGN TYPE: D

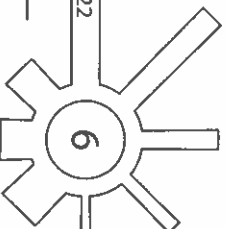

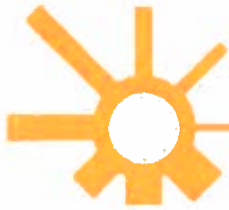

SUNSHINEsign

121 Westboro Road • North Grafton, MA 01536

Owner Authorization

Date: 3/1/22

To whom it may concern:

Laura Valladares agent for SCG 17 Forge Parkway, LLC
| _____

Owner of the property located at 17 Forge Parkway
Franklin, MA 02038

Do hereby consent to allow Suzanne Keene
of Sunshine Sign Company Inc. to act on my behalf in submitting all necessary
design review, building permits, and ZBA applications pertaining to all signage
located at the above mentioned property.

Sincerely,

Laura Valladares-Senior Real Estate Manager, CBRE
| _____

Address: 112 Turnpike Road, Westborough MA 01581

Telephone: 508-366-0800

Email: laura.valladares@cbre.com

(Please Print
Carefully)

Deeded name of property:

SCG 17 Forge Parkway, LLC



SUNSHINEsign

121 Westboro Road • North Grafton, MA 01536

Landlord Authorization

Date: 3/1/22

To whom it may concern:

Laura Valladares agent for SCG 17 Forge Parkway, LLC

Owner of the property located at 17 Forge Parkway
Franklin, MA 02038

Do hereby consent to allow Suzanne Keene
of Sunshine Sign Company Inc. to act on my behalf in submitting all necessary
design review, building permits, and ZBA applications pertaining to all signage
located at the above mentioned property.

Sincerely,

Laura Valladares- Senior Real Estate Manager, CBRE

Address: 112 Turnpike Road, Westborough MA 01581

Telephone: 508-366-0800

Email: laura.valladares@cbre.com

(Please Print
Carefully)

Deeded name of property:
SCG 17 Forge Parkway, LLC

FORM Q

TOWN OF FRANKLIN
DESIGN REVIEW APPLICATION
FOR §185-31(2) OF THE ZONING BY-LAW

A) **General Information**

Name of Business or Project: NISSHA METALIZING SOLUTIONS

Property Address 24 NATIONAL DR

Assessors' Map # 290 Parcel # 005

Zoning District (select applicable zone): I

Zoning History: Use Variance _____

Non-Conforming Use _____

B) **Applicant Information:**

Applicant Name: SUNSHINE SIGN CO INC

Address: 121 WESTBOND RD
GRAFTON MA 01536

Telephone Number: 508 868 5401

Contact Person: WILLIAM KUCK

C) **Owner Information (Business Owner & Property Owner if different)**

Business Owner: NISSHA METALIZING Property Owner: MTPA 24 NATIONAL DR LLC

Address: 24 NATIONAL DR 130 WEST 42ND ST
FRANKLIN MA NEW YORK

All of the information is submitted according to the best of my knowledge
Executed as a sealed instrument this _____ day of _____ 20____

[Signature]
Signature of Applicant

See attached
Signature of Owner

William Kuck
Print name of Applicant

Print name of Owner

***FOR SIGNS COMPLETE PAGES 1 & 2 ONLY.
FOR SITE PLANS, BUILDING PLANS, PROJECTS, COMPLETE PAGES 1 - 4**

SEE ADDENDA ATTACHED FOR ASSISTANCE IN COMPLETION OF FORM Q

D) Architect/Engineer/Sign Company Information (if not the applicant)

a. Sign Company

Business Name: _____

Contact Person: _____

Address _____

Telephone Number: _____

b. Architect/Engineer (when applicable)

Business Name: _____

Contact Person: _____

Address _____

Telephone Number: _____

E) Work Summary

Summary of work to be done: Install one 138.37 SF Non Illuminated
Wall Sign

F) Information & Materials to be Submitted with Application

a) FOR SIGN SUBMISSIONS ONLY:

**THE FOLLOWING MUST BE SUBMITTED ELECTRONICALLY TO
Mkinhart@franklinma.gov**

1. Drawing of Proposed Sign which must also include
type of sign (wall, pylon etc.) colors
size/dimensions materials
style of lettering lighting-illuminated, non-illuminated and style
2. Drawing and/or pictures indicating location of new sign.
3. Picture of existing location and signs (if previously existing location)

b) FOR BUILDINGS/DEVELOPMENTS OR PROJECT SUBMISSIONS:

THE FOLLOWING MUST BE SUBMITTED W/APPLICATION to Mkinhart@franklinma.gov

1. Site Plan including Landscape Plan showing plantings. Plantings must be from Best Development Practices Guide
2. Lighting Plan indicating lighting levels & specifications of proposed lights
3. Building drawings, indicating size and height of building(s); front, rear and side elevations (when there are no adjoining buildings) and floor plans
4. Drawings or pictures of existing conditions
5. If any signage on the building or site, provide information from above Signage Checklist

424

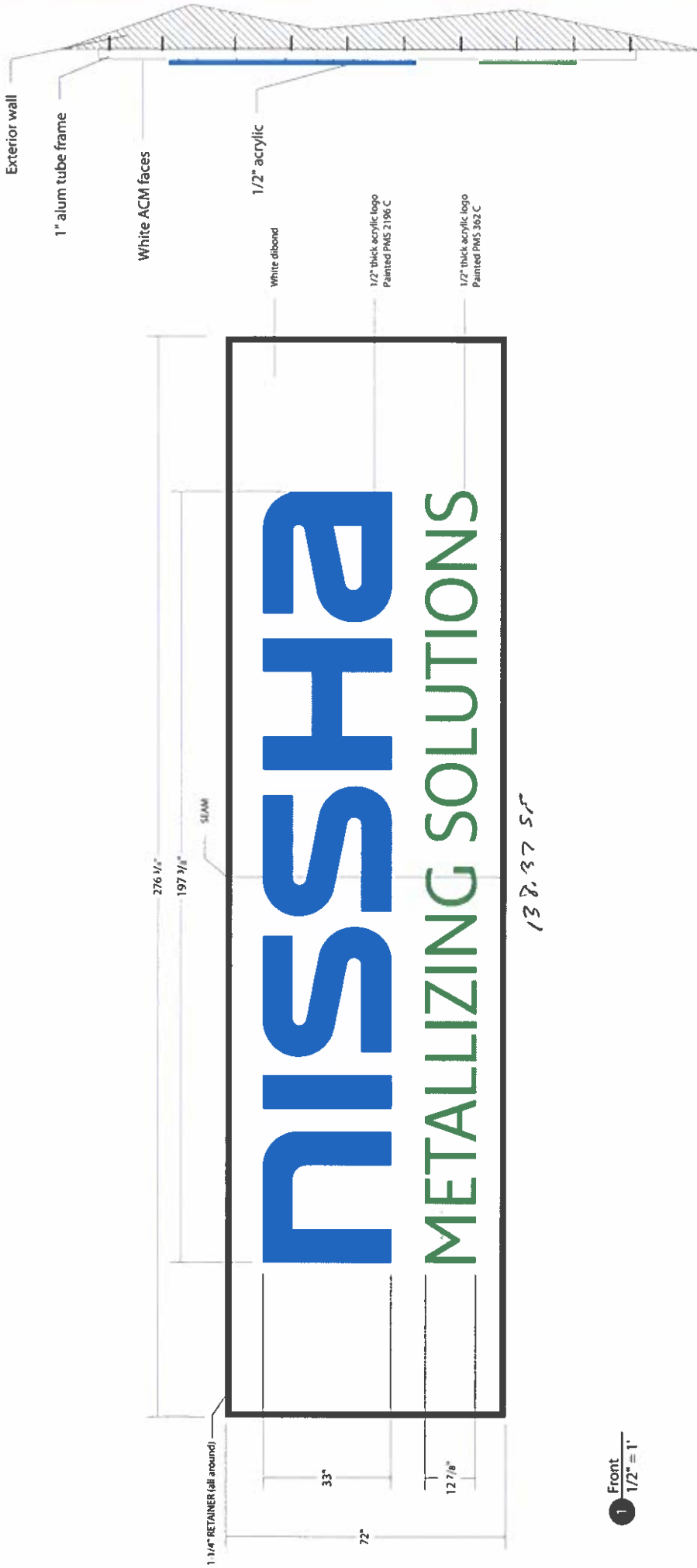

138.37 SF

1 Front
1/2" = 1"

SIGN TYPE C

FAST Sign

Quantity (1)

1" deep FAST sign with aluminum tube frame & prefinished white ACM faces. 1/2" thick painted acrylic logo mechanically fastened to face.

Palette

PAINT: PMS 2196 C
 PAINT: PMS 362 C

CLIENT: AR METALLIZING (NISSHA)

PROJECT / SIGN TYPE: REBRAND

DRAWN BY: JG

JOB #: 17997-68185

DATE: 3/25/22

121 Westboro Road
 North Grafton, MA 01536
 P 508.839.5588
 F 508.839.9929
 www.sunshinesign.com

SUNSHINE sign

Approved for Fabrication
 Approved as Noted
 Revise and Resubmit
 Rejected

This drawing is given in confidence and may not be used or disseminated in any way without prior written consent from Sunshine Sign Company, Inc. All common law and copyright laws are hereby specifically reserved.

Name
Signature

SIGN TYPE: C

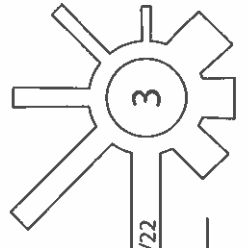

24 Forge Park



CLIENT: AR METALLIZING (NISSHA)

121 Westboro Road
 North Grafton, MA 01536
 P 508.839.5588
 F 508.839.9929
 www.sunshinesign.com

SUNSHINE
SIGN

PROJECT / SIGN TYPE: REBRAND

This drawing is given in confidence and may not be used or disseminated in any way without prior written consent from Sunshine Sign Company, Inc. All common law and copyright laws are hereby specifically reserved.

DRAWN BY: JG

- Approved for Fabrication
 Approved as Noted
 Revise and Resubmit
 Rejected

JOB #: 17997-68185

DATE: 3/25/22

Name _____

Signature _____

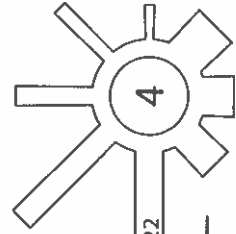

SIGN TYPE: C



SUNSHINEsign

121 Westboro Road • North Grafton, MA 01536

Landlord Authorization

Date: 3.1.22

To whom it may concern:

Fergus Campbell

Owner of the property located at 24 National Drive
Franklin, MA

Do hereby consent to allow _____
of Sunshine Sign Company Inc. to act on my behalf in submitting all necessary
design review, building permits, and ZBA applications pertaining to all signage
located at the above mentioned property.

Sincerely,



Address: 130 West 42nd Street, 22nd Fl, NYC

Telephone: 646-766-8182

Email: joe@someraroadinc.com

(Please Print
Carefully)

Deeded name of property:

MTP - 24 National Drive LLC



SUNSHINEsign

121 Westboro Road • North Grafton, MA 01536

Owner Authorization

Date: 3.1.22

To whom it may concern:

Fergus Campbell

Owner of the property located at 24 National Drive
Franklin, MA

Do hereby consent to allow _____
of Sunshine Sign Company Inc. to act on my behalf in submitting all necessary
design review, building permits, and ZBA applications pertaining to all signage
located at the above mentioned property.

Sincerely,



Address: 130 West 42nd Street, 22nd Fl, NYC

Telephone: 646.766.8182

Email: joe@someraroadinc.com

(Please Print
Carefully)

Deeded name of property:

MTP - 24 National Drive LLC

FORM Q

TOWN OF FRANKLIN
DESIGN REVIEW APPLICATION
FOR §185-31(2) OF THE ZONING BY-LAW

A) General Information

Name of Business or Project: Physicianone Urgent Care

Property Address 648 Old West Central Street

Assessors' Map # Parcel 271-031-000-000 Parcel # Book 33693-267

Zoning District (select applicable zone): _____

Zoning History: Use Variance _____
Non-Conforming Use _____

B) Applicant Information:

Applicant Name: Graphik Sign Solutions, LLC

Address: 36G Kreiger Lane
Glastonbury, CT 06033

Telephone Number: 860-657-9755

Contact Person: Karin Knobel

C) Owner Information (Business Owner & Property Owner if different)

Business Owner: Physicianone Urgent Care
Address: 31 Old Route 7
Brookfield, CT 06804

Property Owner: Franklin Goldfields Properties LLC
ONE VAN DEGRAFF DRIVE
BURLINGTON MA 01803

All of the information is submitted according to the best of my knowledge
Executed as a sealed instrument this 19th day of April 2022

Karin Knobel
Signature of Applicant

John M Kane
Signature of Owner

Karin Knobel
Print name of Applicant

John M Kane
Print name of Owner

***FOR SIGNS COMPLETE PAGES 1 & 2 ONLY.
FOR SITE PLANS, BUILDING PLANS, PROJECTS, COMPLETE PAGES 1 - 4**

SEE ADDENDA ATTACHED FOR ASSISTANCE IN COMPLETION OF FORM Q

D) Architect/Engineer/Sign Company Information (if not the applicant)

a. Sign Company

Business Name: Graphik Sign Solutions, LLC-Same as Applicant

Contact Person: Karin Knobel

Address 36G Kreiger Lane Glastonbury, CT 06033

Telephone Number: 860-657-9755 / 860-682-5098

b. Architect/Engineer (when applicable)

Business Name: N/A

Contact Person: _____

Address _____

Telephone Number: _____

E) Work Summary

Summary of work to be done: Remove existing signage, patch holes and furnish and install new signage as per drawings

F) Information & Materials to be Submitted with Application

a) FOR SIGN SUBMISSIONS ONLY:

THE FOLLOWING MUST BE SUBMITTED ELECTRONICALLY TO Mkinhart@franklinma.gov

1. Drawing of Proposed Sign which must also include
type of sign (wall, pylon etc.) colors
size/dimensions materials
style of lettering lighting-illuminated, non-illuminated and style
2. Drawing and/or pictures indicating location of new sign.
3. Picture of existing location and signs (if previously existing location)

b) FOR BUILDINGS/DEVELOPMENTS OR PROJECT SUBMISSIONS:

THE FOLLOWING MUST BE SUBMITTED W/APPLICATION to Mkinhart@franklinma.gov

1. Site Plan including Landscape Plan showing plantings. Plantings must be from Best Development Practices Guide
2. Lighting Plan indicating lighting levels & specifications of proposed lights
3. Building drawings, indicating size and height of building(s); front, rear and side elevations (when there are no adjoining buildings) and floor plans
4. Drawings or pictures of existing conditions
5. If any signage on the building or site, provide information from above Signage Checklist



GRAPHIK SIGN SOLUTIONS LLC

36-G Kreiger Lane ■ Glastonbury, CT 06033
860.657.9755 ■ E-Mail: gis@snet.net

PROPERTY OWNER AUTHORIZATION MUST BE SIGNED BY OWNER OF PROPERTY

This verifies that you are authorizing Graphik Sign Solutions, LLC to submit an application for permits ON BEHALF OF the owner of the property.

As owner of 648 Old West Central Street - Franklin, MA Date: April 14, 2022
(Property Address)

I hereby authorize Karin Knobel or Jesse Englert, as an authorized representative of Graphik Sign Solutions, LLC, to APPLY FOR SIGN PERMITS for this site.

I hereby authorize Karin Knobel

TO APPEAR BEFORE THE PLANNING BOARD and/or SIGN REVIEW BOARD and/or the ZBA
for this site. AS AGENT FOR FRANKLIN GOLDFIELD PROPERTIES LLC

Property Owner's Signature: [Signature] KEY POINT PARTNERS, LLC

Printed Name: John M Kane

Address: ONE WANE DEGRADFF DRIVE

SUITE 402

BURLINGTON MA 01803

Phone number: 781-418-6262

We cannot apply for permits or hearings until we receive your authorization.

Please EMAIL this completed & signed form to gis@snet.net attn: Karin Knobel
and MAIL ORIGINAL to Graphik Sign Solutions, LLC 36G Kreiger La. Glastonbury, CT 06033

Reference JOB NAME: Physicianone Urgent Care



GRAPHIK SIGN SOLUTIONS LLC

SIGNAGE & BRANDING PROFESSIONALS

36G Kreiger Lane
Glastonbury, CT 06033
860.657.9755

ARCHITECT/DESIGN

CLIENT

Physicianone Urgent Care

APPROVED

APPROVED
AS NOTED

DISAPPROVED - REVISE & RESUBMIT

CLIENT SIGNATURE DATE LANDLORD SIGNATURE DATE

SALESPERSON

PROJ. MANAGER

Karin Knobel

JOB NAME / LOCATION

648 Old West Central Street
Franklin, MA

PROJECT

Wall Sign

INSTALLATIONS

Wall Sign

DWG. NO.

REF. DWG.

POUC396-WS

DATE.

SHEET

3.29.22

1 of 1

REVISION NO. 1



Replace window and door graphics



Existing sign



URGENT CARE

WINDOW GRAPHICS WINDOW GRAPHICS WINDOW GRAPHICS

URGENT CARE 24/7 TELEHEALTH X-RAY

WINDOW GRAPHICS DOOR GRAPHIC WINDOW GRAPHICS

ONLINE BOOKING WALK INS WELCOME



3-TYPICAL RESERVED PARKING



A. ALUMINUM RACEWAY PAINTED WHITE WITH 1" CUT-OUT PUSHED THROUGH ACRYLIC LETTERS

B. ALUMINUM RACEWAY PAINTED RED WITH INDIVIDUAL CHANNEL LETTERS

LETTERS/LOGO ONLY TO ILLUMINATE
ALUMINUM RACEWAY IS NON-ILLUMINATED

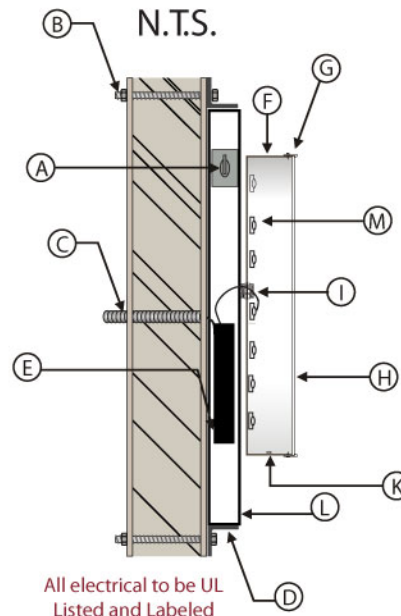
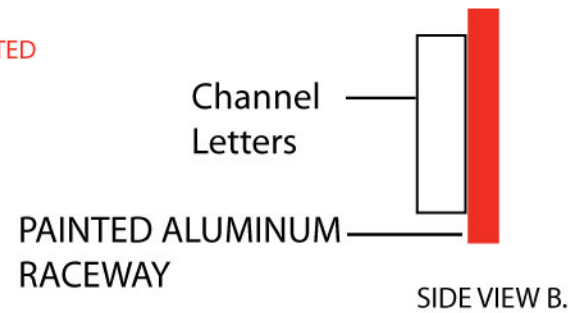
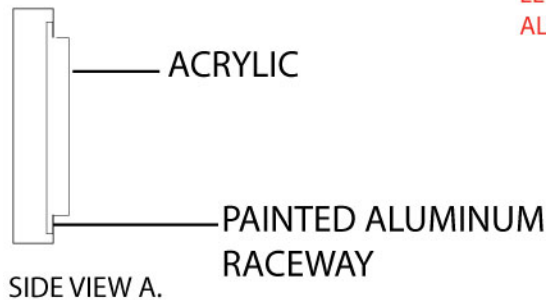

A	listed disconnect switch
B	3/8" galv. through bolt, lock nut
C	primary electrical source
D	galv. mounting shoe (2" x 2")
E	12v power supply
F	.040 aluminum
G	1" trim cap
H	3/16" thick plex face
I	bushing
J	led's
K	weep holes
L	extruded aluminum raceway
M	white led module

120V, 9AMPS



GRAPHIK
SIGN SOLUTIONS LLC

SIGNAGE & BRANDING PROFESSIONALS

36G Kreiger Lane
Glastonbury, CT 06033
860.657.9755

ARCHITECT/DESIGN

KMK

CLIENT

Physicianone Urgent Care

APPROVED APPROVED AS NOTED

DISAPPROVED - REVISE & RESUBMIT

SALESPERSON PROJ. MANANGER

Karin Knobel

JOB NAME / LOCATION

648 Old West Central Street
Franklin, MA

PROJECT

Wall Sign

INSTALLATIONS

Wall Sign

DWG. NO. REF. DWG.

3377RH-WS

DATE SHEET

3.29.22 1 of 1

REVISION NO.1



GRAPHIK SIGN SOLUTIONS LLC

SIGNAGE & BRANDING PROFESSIONALS

36G Kreiger Lane
Glastonbury, CT 06033
860.657.9755

ARCHITECT/DESIGN

CLIENT

Physicianone Urgent Care

APPROVED

APPROVED
AS NOTED

DISAPPROVED - REVISE & RESUBMIT

CLIENT SIGNATURE DATE LANDLORD SIGNATURE DATE

SALESPERSON

PROJ. MANAGER

Karin Knobel

JOB NAME / LOCATION

648 Old West Central Street
Franklin, MA

PROJECT

Wall Sign

INSTALLATIONS

Wall Sign

DWG. NO.

REF. DWG.

POUC390-WS

DATE.

SHEET

3.29.22

1 of 1

REVISION NO.1



Franklin, MA-REAR BUILDING SIGN

FULL BACK ALUMINUM RACEWAY
 PAINTED RED WITH
 INDIVIDUAL WHITE LED CHANNEL LETTERS

16 sq. ft.



PAINTED PMS-485c
 3M Light Tomato Red

Letters only to illuminate

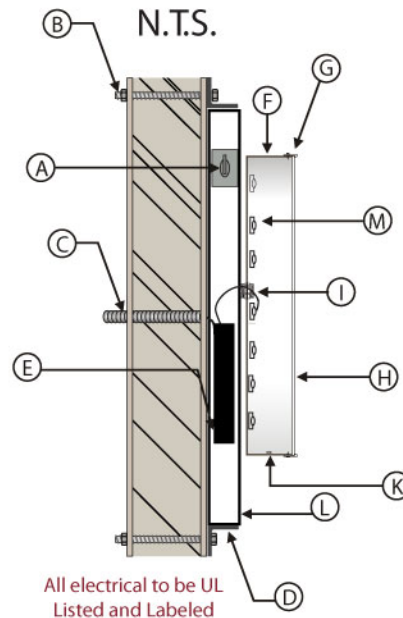
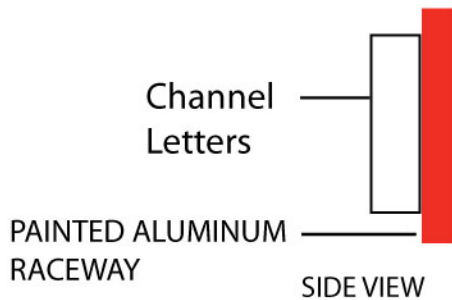

A	listed disconnect switch
B	3/8" galv. through bolt, lock nut
C	primary electrical source
D	galv. mounting shoe (2" x 2")
E	12v power supply
F	.040 aluminum
G	1" trim cap
H	3/16" thick plex face
I	bushing
J	led's
K	weep holes
L	extruded aluminum raceway
M	white led module

120V, 9AMPS



GRAPHIK
 SIGN SOLUTIONS LLC

SIGNAGE & BRANDING PROFESSIONALS

36G Kreiger Lane
 Glastonbury, CT 06033
 860.657.9755

ARCHITECT/DESIGN			
CLIENT			
Physicianone Urgent Care			
<input type="checkbox"/> APPROVED		<input type="checkbox"/> APPROVED AS NOTED	
<input type="checkbox"/> DISAPPROVED - REVISE & RESUBMIT			
CLIENT SIGNATURE	DATE	LANDLORD SIGNATURE	DATE
SALESPERSON		PROJ. MANAGER	
		Karin Knobel	
JOB NAME / LOCATION			
648 Old West Central Street Franklin, MA			
PROJECT			
Wall Sign			
INSTALLATIONS			
Wall Sign			
DWG. NO.		REF. DWG.	
3390S-W5			
DATE		SHEET	
4.5.22		1 of 1	
REVISION NO.1			

Reface Existing
Projecting sign
4 sq. ft.



GRAPHIK SIGN SOLUTIONS LLC

SIGNAGE & BRANDING PROFESSIONALS

36G Kreiger Lane
Glastonbury, CT 06033
860.657.9755

ARCHITECT/DESIGN

CLIENT

Physicianone Urgent Care

APPROVED

APPROVED
AS NOTED

DISAPPROVED - REVISE & RESUBMIT

CLIENT SIGNATURE

DATE

LANDLORD SIGNATURE

DATE

SALESPERSON

PROJ. MANANGER

Karin Knobel

JOB NAME / LOCATION

648 Old West Central Street
Franklin, MA

PROJECT

Projecting Sign

INSTALLATIONS

Projecting Sign

DWG. NO.

REF. DWG.

POUC394-P

DATE.

SHEET

3.28.22

1 of 1

REVISION NO.1



Reface pylon sign
with 3/16" white polycarbonate
with surface applied
3m red translucent PMS-485
vinyl

14 sq. ft

**URGENT
CARE**

Sage
SALON



GRAPHIK SIGN SOLUTIONS LLC

SIGNAGE & BRANDING PROFESSIONALS

36G Kreiger Lane
Glastonbury, CT 06033
860.657.9755

ARCHITECT/DESIGN

LIENT
Physicianone Urgent Care

APPROVED APPROVED AS NOTED
 DISAPPROVED - REVISE & RESUBMIT

CLIENT SIGNATURE	DATE	LANDLORD SIGNATURE	DATE

SALESPERSON	PROJ. MANANGER
	Karin Knobel

OB NAME / LOCATION
648 Old West Central Street
Franklin, MA

PROJECT
Pylon Sign

INSTALLATIONS
Pylon Sign

DWG. NO.	REF. DWG.
POUC390-P	

ATE.	SHEET
3.28.22	1 of 1

REVISION NO.1



GRAPHIK SIGN SOLUTIONS LLC

SIGNAGE & BRANDING PROFESSIONALS

36G Kreiger Lane
Glastonbury, CT 06033
860.657.9755

ARCHITECT/DESIGN

CLIENT

Physicianone Urgent Care

APPROVED APPROVED AS NOTED

DISAPPROVED - REVISE & RESUBMIT

CLIENT SIGNATURE	DATE	LANDLORD SIGNATURE	DATE
------------------	------	--------------------	------

SALESPERSON	PROJ. MANAGER
-------------	---------------

Karin Knobel

JOB NAME / LOCATION

648 Old West Central St.
Franklin, MA

PROJECT

Door Lettering

INSTALLATIONS

Door Lettering

DWG. NO.	REF. DWG.
----------	-----------

POUC3390-DFM

DATE.	SHEET
-------	-------

3.30.22 1 of 1

REVISION NO.1

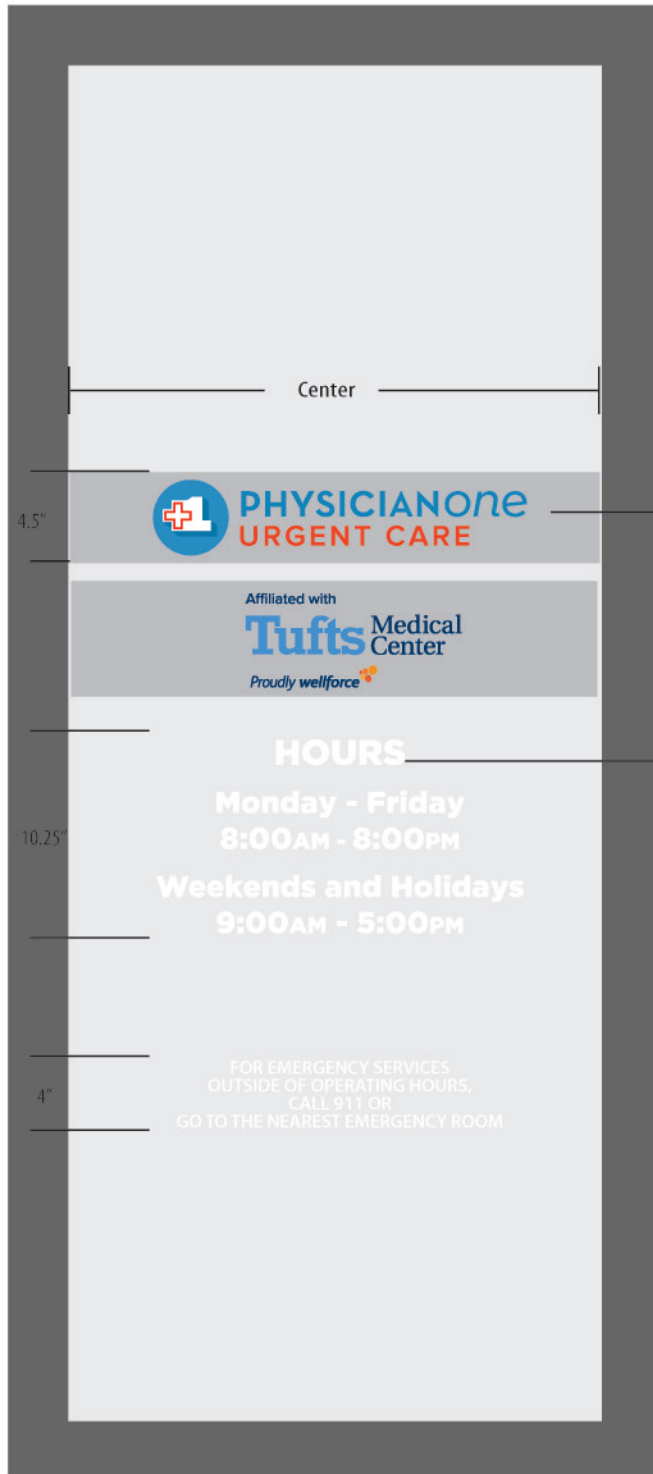

Applied 3m frosted bands

Applied 3m vinyl lettering

SINGLE DOOR

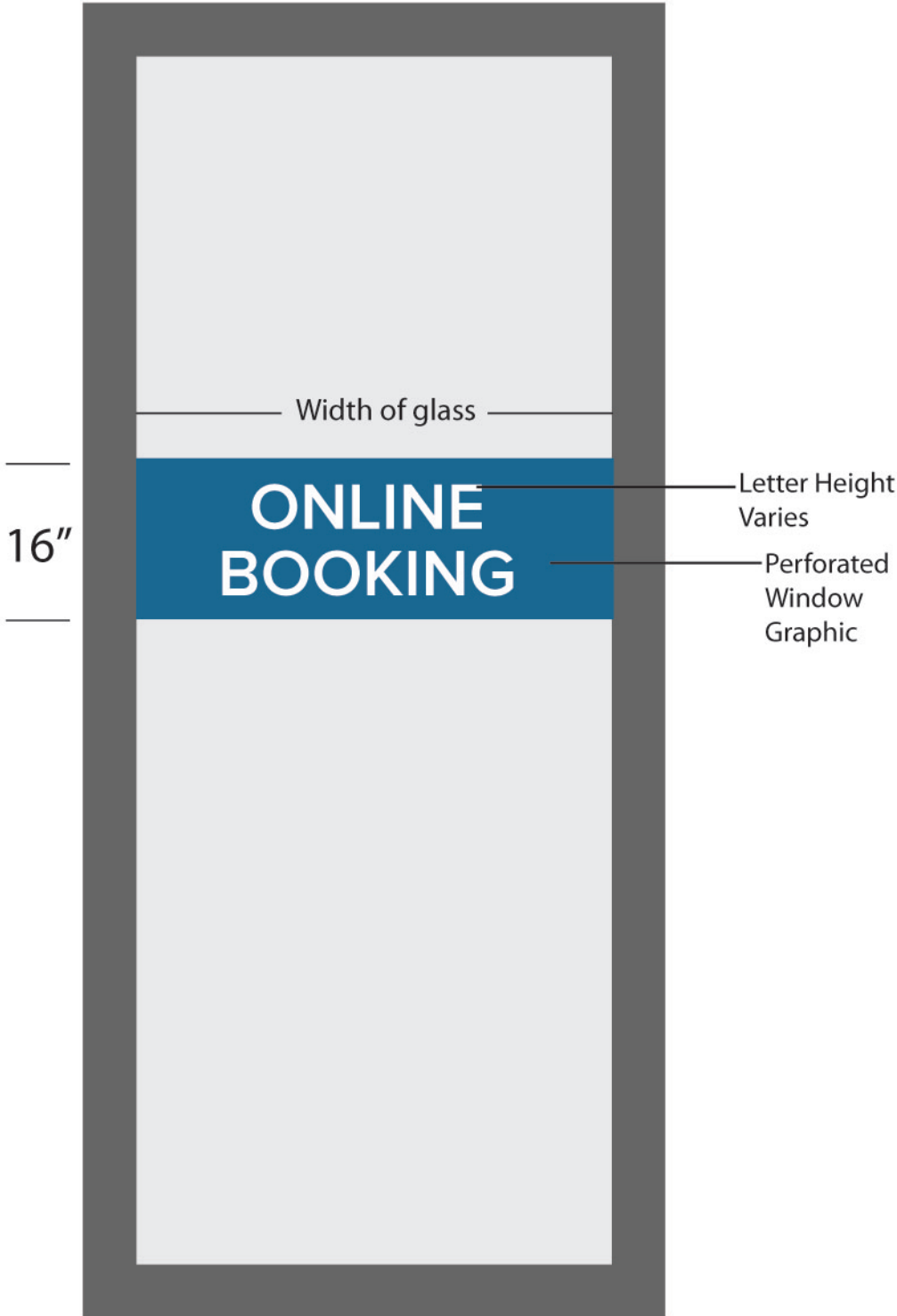

TYPICAL



GRAPHIK
SIGN SOLUTIONS LLC

SIGNAGE & BRANDING PROFESSIONALS

36G Kreiger Lane
Glastonbury, CT 06033
860.657.9755

ARCHITECT/DESIGN			
CLIENT			
Physicianone Urgent Care			
<input type="checkbox"/> APPROVED		<input type="checkbox"/> APPROVED AS NOTED	
<input type="checkbox"/> DISAPPROVED - REVISE & RESUBMIT			
CLIENT SIGNATURE	DATE	LANDLORD SIGNATURE	DATE
SALESPERSON		PROJ. MANAGER	
		Karin Knobel	
JOB NAME / LOCATION			
648 Old West Central St. Franklin, MA			
PROJECT			
Window Graphic			
INSTALLATIONS			
Window Graphic			
DWG. NO.		REF. DWG.	
POUC3397-DFM			
DATE.		SHEET	
3.31.22		1 of 1	
REVISION NO.1			



Reserved parking signs
 3-.080 18" X 12" reflective
 aluminum sign panels



Galvanized Post



Asphalt Parking Lot



GRAPHIK
 SIGN SOLUTIONS LLC

SIGNAGE & BRANDING PROFESSIONALS

36G Kreiger Lane
 Glastonbury, CT 06033
 860.657.9755

ARCHITECT/DESIGN	
KMK	
CLIENT	
Physicianone Urgent Care	
<input type="checkbox"/> APPROVED	<input type="checkbox"/> APPROVED AS NOTED
<input type="checkbox"/> DISAPPROVED - REVISE & RESUBMIT	
SALESPERSON	PROJ. MANAGER
	Karin Knobel
JOB NAME / LOCATION	
648 Old West Central Street Franklin, MA	
PROJECT	
Reserved Parking	
INSTALLATIONS	
Reserved Parking	
DWG. NO.	REF. DWG.
3407RH-RPB	
DATE.	SHEET
4.11.22	1 of 1
REVISION NO. 1	

FORM Q

TOWN OF FRANKLIN
DESIGN REVIEW APPLICATION
FOR §185-31(2) OF THE ZONING BY-LAW

A) General Information

Name of Business or Project: Prospect Hill Country Day School

Property Address 54 Prospect Street

Assessors' Map # 323 Parcel # 020

Zoning District (select applicable zone): _____

Zoning History: Use Variance _____
Non-Conforming Use _____

B) Applicant Information:

Applicant Name: Cavallaro Signs INC

Address: 305 Union Street
Franklin, MA 02038

Telephone Number: 508-528-6545

Contact Person: Rocco Cavallaro

C) Owner Information (Business Owner & Property Owner if different)

Business Owner: Kay Mac Donald Property Owner: Kay Mac Donald

Address: 54 Prospect Street Same Address
Franklin MA 02038

All of the information is submitted according to the best of my knowledge
Executed as a sealed instrument this _____ day of _____ 20____

[Signature]
Signature of Applicant

[Signature]
Signature of Owner

Rocco Cavallaro
Print name of Applicant

Kay Mac Donald
Print name of Owner

***FOR SIGNS COMPLETE PAGES 1 & 2 ONLY.
FOR SITE PLANS, BUILDING PLANS, PROJECTS, COMPLETE PAGES 1-4**

SEE ADDENDA ATTACHED FOR ASSISTANCE IN COMPLETION OF FORM Q

D) Architect/Engineer/Sign Company Information (if not the applicant)

a. Sign Company

Business Name: Cavallaro Signs Inc.
Contact Person: Rocco Cavallaro
Address: 305 Union Street
Telephone Number: 508-528-6545

b. Architect/Engineer (when applicable)

Business Name: _____
Contact Person: _____
Address: _____
Telephone Number: _____

E) Work Summary

Summary of work to be done: Replacement Sign
53" x 48" PVC 3/4 With Color Print + Overlay
PT Wood Posts, and PVC Post Covers

F) Information & Materials to be Submitted with Application

a) FOR SIGN SUBMISSIONS ONLY:

**THE FOLLOWING MUST BE SUBMITTED ELECTRONICALLY TO
Mkinhart@franklinma.gov**

1. Drawing of Proposed Sign which must also include
type of sign (wall, pylon etc.) colors
size/dimensions materials
style of lettering lighting-illuminated, non-illuminated and style
2. Drawing and/or pictures indicating location of new sign.
3. Picture of existing location and signs (if previously existing location)

b) FOR BUILDINGS/DEVELOPMENTS OR PROJECT SUBMISSIONS:

THE FOLLOWING MUST BE SUBMITTED W/APPLICATION to Mkinhart@franklinma.gov

1. Site Plan including Landscape Plan showing plantings. Plantings must be from Best Development Practices Guide
2. Lighting Plan indicating lighting levels & specifications of proposed lights
3. Building drawings, indicating size and height of building(s); front, rear and side elevations (when there are no adjoining buildings) and floor plans
4. Drawings or pictures of existing conditions
5. If any signage on the building or site, provide information from above Signage Checklist



Design / Artwork _____

Date..... **4/20/22**

Prospect Hill Country Day School
54 Prospect Street

Replacement sign, double sided
48 x 53" Sign panel

5'10" Tall



24" from ground....

Cement installation
PT posts 4x4 and PVC post covers



Cavallaro Signs
I N C O R P O R A T E D

305 Union St., Franklin, Ma phone/fax 508-528-6545

Site Study

Date..... **4/20/22**

Prospect Hill Country Day School
54 Prospect Street

Replacement sign, double sided, Installed into same holes....
48 x 53" Sign panel



Cement installation
PT posts 4x4 and PVC post covers

Town of Franklin



Design Review Commission

**Tuesday, April 12, 2022
Meeting Minutes,**

Chair James Bartro called the above-captioned meeting to order this date at 7:00 PM, as a remote access virtual Zoom meeting. Members in attendance: Chair James Bartro, Vice Chair Sam Williams, Venkata Sompally, Gerald Wood. Members absent: Associate Chris Baryluk. Also present: Maxine Kinhart, Administrative Staff.

As stated on the agenda, due to the continued concerns regarding the COVID-19 virus, this meeting will be conducted as a remote/virtual Design Review Commission meeting. In an effort to ensure citizen engagement and comply with open meeting law regulations, citizens will be able to dial into the meeting using the provided phone number, or citizens can participate by using the Zoom link provided on the agenda. This meeting was recorded.

1. Vendetti Motors – 411 West Central Street – Install channel letter set.

Mr. Cam Afonso of Signs by Cam, Inc. addressed the Commission. He stated that a channel letter set on a raceway will be installed on the side of the building that faces Panther Way. He stated that the channel letter set will mimic the sign/colors of the customer service sign on the front of the building. Chair Bartro stated that he looked at this as a directional sign to let people know where to go for collision services, and it does not have the Vendetti logo on it; therefore, he is not even sure the Design Review Commission needed to review this. Commission members informally agreed.

Motion: To **Accept** the sign package as submitted. Motioned by S. Williams. Seconded by V. Sompally. Roll Call Vote: Williams-YES; Sompally-YES; Wood-YES; Bartro-YES. Voted 4-0-0.

2. The Shed – 340 East Central Street – Install 3D sign & pylon panels.

Mr. Cam Afonso of Signs by Cam, Inc. addressed the Commission. He stated that this is basically a brewery type restaurant which is going next to the Big Y and the apartment complex. He stated that this will be aluminum and PVC three-dimensional logo with a custom-made beer tap protruding off the sign. The lighting specifications are on the proposed drawing. He confirmed the pylon sign will be internally illuminated. Chair Bartro noted the sign box itself could use some enhancement. Mr. Afonso stated that he would mention it. Chair Bartro requested the sign attachment method be provided. Mr. Afonso stated that he would provide it. Mr. Williams noted that due to all the negative space in the sign, it makes the sign compliant with the size requirements. Chair Bartro requested that information be put on the drawing.

Motion: To **Accept** the sign package as submitted including an attachment method and some additional dimensions. Motioned by S. Williams. Seconded by V. Sompally. Roll Call Vote: Williams-YES; Sompally-YES; Wood-YES; Bartro-YES. Voted 4-0-0.

3. **Middlesex Savings Bank – 1000 Franklin Village Drive** – Install one (1) sign over main entrance – halo lit letters/logo mounted to aluminum backer, install one (1) sign over drive thru canopy consisting of halo mounted to aluminum backer.

Chair Bartro noted that this is a redo of some of the existing signage. Mr. Scott Spaulding, representing the applicant, addressed the Commission. He stated that this is a rebranding for all the locations. He stated that the canopy sign over the drive-up banking will have opaque background and be backlit; it is a replacement sign to what is already there and will be the same size. Chair Bartro noted that the edge lighting was very good. Mr. Spaulding reviewed the sign over the main entrance. Chair Bartro stated that including the highway signs which are grandfathered in, he thinks that the applicant is over the allowed square footage. Mr. Williams noted that this is in the commercial business corridor; he read aloud the sign square footage allowances. Chair Bartro discussed highway facing signs. He asked what the other commissioners think. Mr. Williams stated that he feels what the applicant is trying to accomplish is perfectly reasonable by putting the sign on the front of the building so people know that it is the entry and having the existing sign for the drive-through canopy. Chair Bartro stated that these signs serve a very specific purpose and they seem well sized for the building; subtracting the existing grandfathered highway sign, these are well within the guidelines.

Motion: To **Accept** the sign package as submitted. Motioned by S. Williams. Seconded by G. Wood. Roll Call Vote: Williams-YES; Sompally-YES; Wood-YES; Bartro-YES. Voted 4-0-0.

Chair Bartro reminded the applicant that when it comes time for the highway facing sign, the applicant must have a conversation with the Commission.

4. **The Dental Boutique – 273 East Central Street** – New sign going outside the building and on the pylon at Horace Mann Plaza.

Mr. Scott Spaulding, on behalf of the applicant, reviewed proposed signage. He stated that this is a set of channel letters. He stated that the applicant read the code and thought they were allowed 20 percent of the façade area. However, he thinks the code may be something else. Chair Bartro stated that this is in the commercial business district; he reviewed the square footage allowances and noted that the maximum allowance is 48 sq. ft. He discussed the negative space on the proposed channel letter sign. Mr. Spaulding calculated the amount without the tooth is 31.5 sq. ft. Chair Bartro stated that he does not think the tooth is greater than 10 sq. ft. Mr. Williams stated that he thinks that with a little more precise calculation, the applicant would be okay. Mr. Spaulding stated that his calculation shows he would be under the allowance. Chair Bartro stated that if this passes, the applicant will send in an altered notation under the drawing that demonstrates what the Commission just talked about. Mr. Spaulding stated that he would calculate each piece and send it in.

Motion: To **Accept** the sign package as submitted provided that it is updated with the proper square footage allowance and the proper square footage calculation on the positive space. Motioned by S. Williams. Seconded by V. Sompally. Roll Call Vote: Williams-YES; Sompally-YES; Wood-YES; Bartro-YES. Voted 4-0-0.

5. **Smiley Gas and Convenience – 52 East Central Street** – Rebranding gas station signage from Gulf and DB Mart to Smiley Gas & Convenience.

Mr. Mark Libman of New Hampshire Signs addressed the Commission. He stated that this is a rebranding from Gulf to Smiley Gas. He stated that the owner wishes to reintroduce the smiley image which was known to the town for over 60 years. He reviewed the rebranding signage for the dispensers, canopy, pylon, and the two existing building signs. He noted the LED displays for the fuel prices. He stated that there is no change in the signage size. Chair Bartro confirmed the proposed signage is all replacing existing signage; there is no added signage. He stated that the convenience sign piece at the bottom with the white background needs to be opaque. He stated that the colors are difficult. He confirmed that this is not a national brand; these are

the owners personal colors. He stated that the yellow bumblebee color is tough in the downtown. Mr. Williams stated that in the bylaws it talks about being in the New England character especially in the downtown. Although he looked through the Design Review guidelines, he could not find anything that specifically said that what the applicant is proposing is not allowed. However, he does feel that it is not in the New England feel. Chair Bartro stated that he is happy the owner is investing in his building and the Commission wants to see businesses thrive in downtown. He asked the owner if he would be willing to come back to the Commission with a less loud color for this signage. Mr. Nabil Nakhoul, owner, stated that he did not mind making it a little less yellow. Chair Bartro stated that the applicant would be put on the next Commission meeting agenda. Mr. Libman stated that they can take care of modifying the color.

Motion: To **Table** the submission. Motioned by S. Williams. Seconded by G. Wood. Roll Call Vote: Williams-YES; Sompally-YES; Wood-YES; Bartro-YES. Voted 4-0-0.

6. NISHA Metallizing Solutions – 17 National Drive – Install one (1) non-illuminated sign.

Ms. Suzanne Keene from Sunshine Sign Company stated that she is representing both 17 and 24 National Drive. Chair Bartro stated that he sent the Building Commissioner a note that these signs are both significantly oversized from what is permitted in the zoning bylaw for the industrial office park district. He stated that he thinks the look and placement is not a challenge. He noted that the bylaw indicates no more than 60 sq. ft. or no more than 90 sq. ft. for a corner building. He does not think these are corner buildings. Ms. Keene stated that she can communicate this back to her team and they can make the appropriate revisions. Chair Bartro stated that the applicant could return to the Commission at the next meeting date. Ms. Keene confirmed that each building could have up to 60 sq. ft.

No Motion Made.

7. NISHA Metallizing Solutions – 24 National Drive – Install one (1) non-illuminated sign.

This agenda item was discussed during agenda item #6.

8. 94 East Central Street – 88, 94, 70 & 72 East Central Street – Construction of a new mixed-use building with approximately 972 sq. ft. of commercial space and 17 residential units.

Mr. Brad Chaffee, owner/applicant, addressed the Commission. Mr. Chaffee reviewed the history of the site. He noted that he has been to the Design Review Commission twice before and approved by the Commission on aesthetics. He stated that the major changes to this site include scaled down height of the building and a green space in the front of the property. The colors and materials of the building have not changed. He stated that they were before the Planning Board for a site plan change; the Planning Board closed the public hearing meeting last night. He stated that a recommendation from the Design Review Commission is one of the Planning Board's conditions. Mr. Chaffee began his review of the project starting with sheet 3 of the provided plan submission. He discussed that two buildings are already completed; this phase encompasses a third building. He reviewed the location of the abutters. He reviewed sheet 5 regarding landscaping, screening, and the elevations. He discussed that as of now the green space will be private to the residents there. He stated that they have made sure there is no light spillage on the abutters to the rear. He discussed the parking lot lighting and wall pack lights. He reviewed the colors of the building; he stated that the colors are from the same color palette with a little more contrast. Chair Bartro stated that he thinks it is a good material palette submitted with this. Mr. Williams said that he thinks it was a good job as it ties into the other buildings. Mr. Chaffee stated that the AC units are on the gable ends. He stated that the clock is on the rendering, but not on the site plan. He stated that when he returns to the Commission for signage, he would like to have a landscaped area with a sign and a clock. Chair Bartro confirmed that the clock would not be included in tonight's submission and the applicant will return with signage.

Motion: To **Recommend** the site plan, photometrics, landscaping, and materials as submitted. Motioned by S. Williams. Seconded by G. Wood. Roll Call Vote: Williams-YES; Sompally-YES; Wood-YES; Bartro-YES. Voted 4-0-0.

Approval of Minutes: March 22, 2022

Motion: To **Approve** the March 22, 2022 Meeting Minutes as presented. Motioned by G. Wood. Seconded by S. Williams. Roll Call Vote: Williams-YES; Sompally-YES; Wood-YES; Bartro-YES. Voted 4-0-0.

General Matters - Old Business

None.

General Matters - New Business

Chair Bartro stated that a concerned citizen reached out to him about a particular sign in town that they described as a derelict sign. He noted the British Beer Company sign installed on the back of the Franklin Village Plaza. He said that led him to go around town to look for other signs that are clearly under non-compliance or are not permitted. He stated that he does not recall the Subway sign on West Central Street coming before the Commission. He noted Mak's sign. He asked the Commissioner members to keep their eyes out for such signs. During an upcoming meeting agenda, they will discuss and agree on a list of signs that are non-compliant or did not come before the Commission; they will send the list to the Building Commissioner for enforcement.

Motion to Adjourn by S. Williams. Seconded by G. Wood. Roll Call Vote: Williams-YES; Sompally-YES; Wood-YES; Bartro-YES. Voted 4-0-0.

Meeting adjourned at 8:07 PM.

Respectfully submitted,

Judith Lizardi
Recording Secretary