

DESIGN REVIEW COMMISSION

AGENDA - *Amended*

January 25, 2022
7:00 PM

Virtual Meeting

Due to the growing concerns regarding the COVID-19 virus, we will be conducting a remote/virtual Design Review Commission Meeting. In an effort to ensure citizen engagement and comply with open meeting law regulations, citizens will be able to dial into the meeting using the provided phone number (Cell phone or Landline Required) OR citizens can participate by copying the link (Phone, Computer, or Tablet required). Please click on <https://us02web.zoom.us/j/89452036292> or call on your phone at 1-929-205-6099, meeting ID is 89452036292

- 7:00 PM** **Bellagio Nail Bar & Lashes – 340 East Central Street**
Attach two back-lit channel letter signs to the building
- 7:05 PM** **Briller Boutique– 70 East Central Street**
Replace existing signage
- 7:10 PM** **Dean College – 119 Main Street**
Replace 4 monument signs
- 7:15 PM** **Avantor – 161 Grove Street**
Replace existing wall sign. Non-illuminated channel letters

General Matters:

Approval of Minutes: January 11, 2022

COMMENTS: These listing of matters are those reasonably anticipated by the Chair which may be discussed at the meeting. Not all items listed may in fact be discussed and other items not listed may also be brought up for discussion to the extent permitted by law.

This agenda is subject to change. Last updated: 1-21-2022

The next meeting of the Design Review Commission is scheduled for February 8, 2022

FORM Q

TOWN OF FRANKLIN
DESIGN REVIEW APPLICATION
FOR §185-31(2) OF THE ZONING BY-LAW

A) General Information

Name of Business or Project: Bellagio Nail Bar & Lashes

Property Address 340 East Central St. Franklin, MA 02038

Assessors' Map # 285-609-000 Parcel # _____

Zoning District (select applicable zone): CII

Zoning History: Use Variance _____
Non-Conforming Use _____

B) Applicant Information:

Applicant Name: New CC Sign Inc.

Address: 259 Quincy Ave.
Quincy MA 02169

Telephone Number: 857-205-5678

Contact Person: Ricky Zeng

C) Owner Information (Business Owner & Property Owner if different)

Business Owner: Tammy Tran Property Owner: 340 East Central St LLC
Address: _____

All of the information is submitted according to the best of my knowledge
Executed as a sealed instrument this _____ day of _____ 20____

Ricky Zeng
Signature of Applicant

[Signature]
Signature of Owner

Ricky Zeng
Print name of Applicant

Joseph Holligan 340 East Central St LLC
Print name of Owner

***FOR SIGNS COMPLETE PAGES 1 & 2 ONLY.
FOR SITE PLANS, BUILDING PLANS, PROJECTS, COMPLETE PAGES 1 - 4**

SEE ADDENDA ATTACHED FOR ASSISTANCE IN COMPLETION OF FORM Q

[Signature]

D) Architect/Engineer/Sign Company Information (if not the applicant)

a. Sign Company

Business Name: New CC Sign Inc.

Contact Person: Ricky Zeng

Address 259 Quincy Ave. Quincy, MA 02169

Telephone Number: 857-205-5678

b. Architect/Engineer (when applicable)

Business Name: _____

Contact Person: _____

Address _____

Telephone Number: _____

E) Work Summary

Summary of work to be done: Attached two back-lit channel letter sign to the building

F) Information & Materials to be Submitted with Application

a) FOR SIGN SUBMISSIONS ONLY:

**THE FOLLOWING MUST BE SUBMITTED ELECTRONICALLY TO
Mkinhart@franklinma.gov**

1. Drawing of Proposed Sign which must also include
type of sign (wall, pylon etc.) colors
size/dimensions materials
style of lettering lighting-illuminated, non-illuminated and style
2. Drawing and/or pictures indicating location of new sign.
3. Picture of existing location and signs (if previously existing location)

b) FOR BUILDINGS/DEVELOPMENTS OR PROJECT SUBMISSIONS:

THE FOLLOWING MUST BE SUBMITTED W/APPLICATION to Mkinhart@franklinma.gov

1. Site Plan including Landscape Plan showing plantings. Plantings must be from Best Development Practices Guide
2. Lighting Plan indicating lighting levels & specifications of proposed lights
3. Building drawings, indicating size and height of building(s); front, rear and side elevations (when there are no adjoining buildings) and floor plans
4. Drawings or pictures of existing conditions
5. If any signage on the building or site, provide information from above Signage Checklist

207"

BELLAGIO NAIL BAR & LASHES

38.50" 24" 68.50" 10" 2"

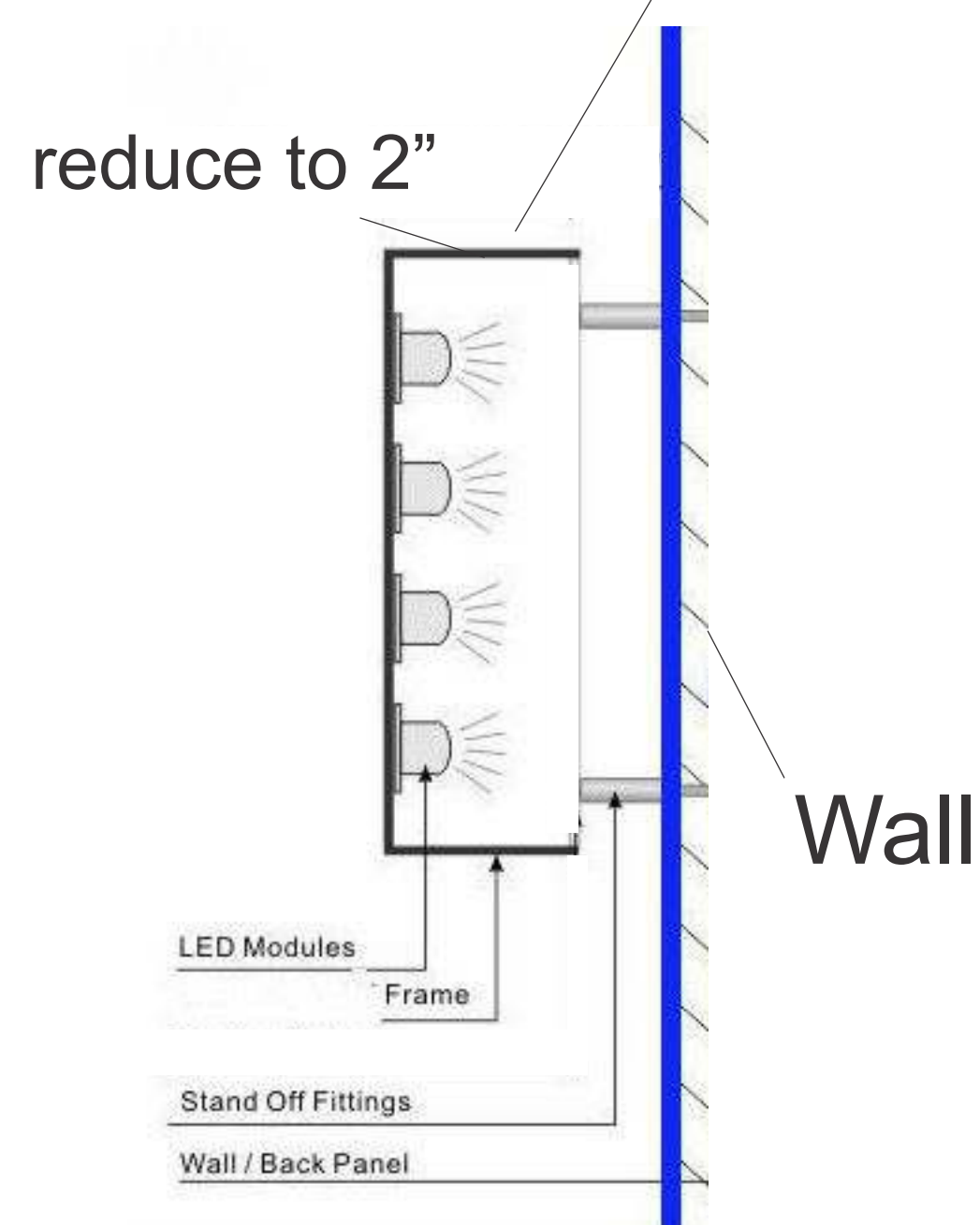
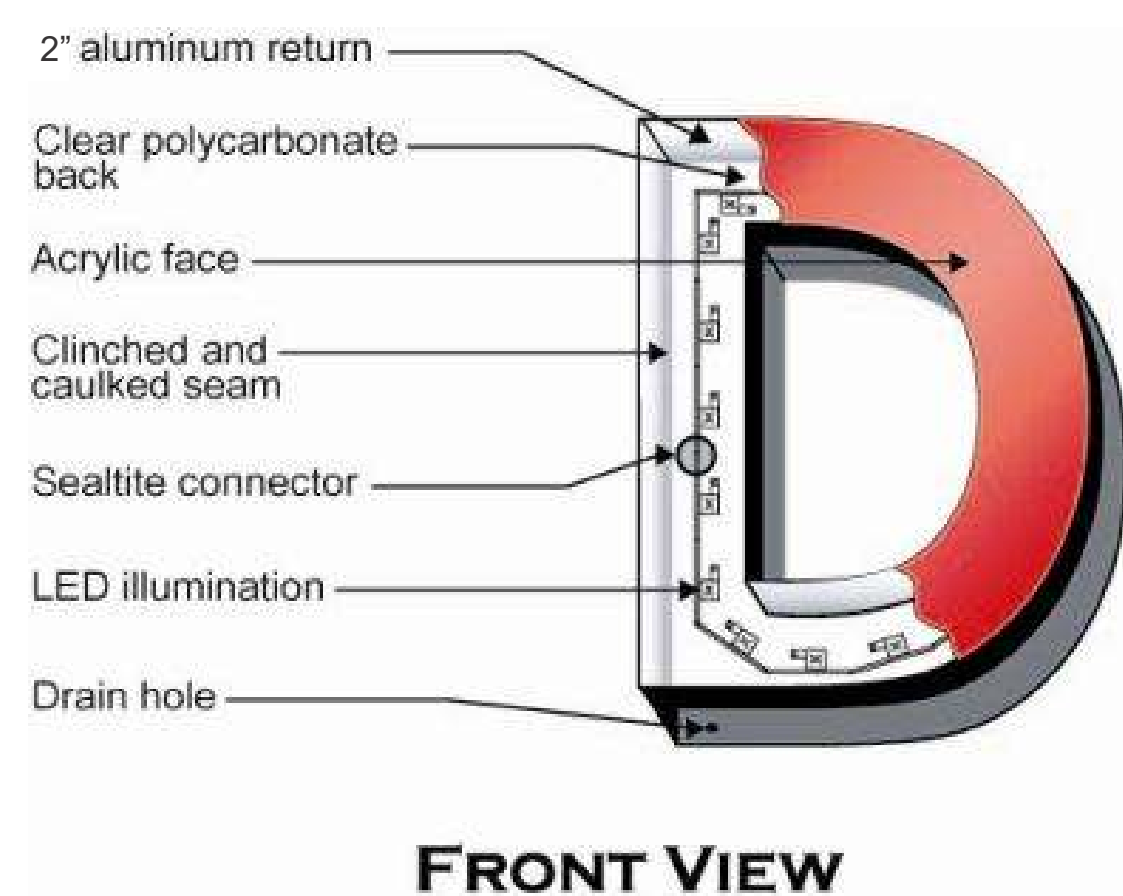

Specifications:

- * 040 gold aluminum light boxes 2" return.
- * Internal white led lighting illumination, UL Listed.
- * Letter boxes to be mounted on the wall.

Sign installed in location shown on attached photo.

This sign is intended to be installed in accordance with the requirement of Article 600 of the National Electrical Code and/or other applicable local code. This includes proper grounding and bonding of the sign.

Mounting

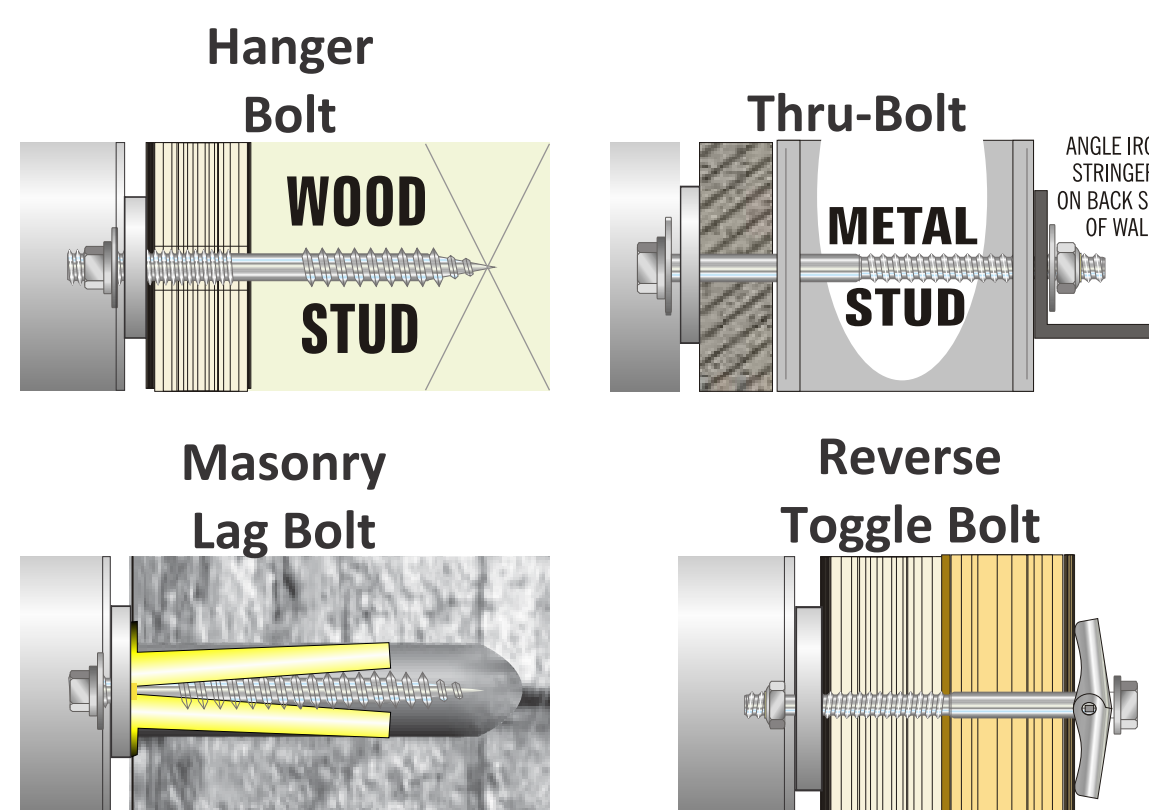

*All Hardware to be Galvanized and Non Corrosive

SQUARE FEET : 55.3

Aluminum Backlit Sign(2 sets):

This image is for general reference only, and may not accurately represent the actual product.

Customer: **Tammy Tran**
 Company: **Bellagio Nail Bar & Lashes**
 Phone: **617-653-8930**
 Original: **12/15/2021** Revision:
 Estimate(\$0 Means No Price):

Address: **340 East Central St.**
 City: **Franklin**
 State/Zip: **MA 02038**
 File Name: **Bellagio Nail**
 Job No: **03465**

The undersigned, in his or her individual and official capacity, hereby certifies that the quoted prices, designs, specifications, terms, and conditions are accepted. New CC Sign is authorized to perform the work as specified.

X _____ Date _____
 Print Name _____

NEW CC SIGN
 259 Quincy Ave. Quincy, MA 02169
 TEL: 617.479.8552 / 617-210-7982
 Fax: 617.479.4852
ccsignboston@gmail.com
 NEW CC Sign ALL RIGHTS RESERVED

Existing



Proposed



FORM Q

TOWN OF FRANKLIN
DESIGN REVIEW APPLICATION
FOR §185-31(2) OF THE ZONING BY-LAW

A) General Information

Name of Business or Project: Brillen Boutique

Property Address 70 East Central St.

Assessors' Map # _____ Parcel # 286-034-000-101

Zoning District (select applicable zone): _____

Zoning History: Use Variance _____
Non-Conforming Use _____

B) Applicant Information:

Applicant Name: _____
Address: _____
Signs By Cam, Inc.
837 Upper Union Street
Suite C-18
Franklin, MA 02038

Telephone Number: 508-364-2905

Contact Person: Cam

C) Owner Information (Business Owner & Property Owner if different)

Business Owner: Somethg Beers Property Owner: 70 E. Central LLC
Address: 70 E. Central Unit @ 70 E. Central
Franklin, MA 02038 Franklin, MA 02038

All of the information is submitted according to the best of my knowledge
Executed as a sealed instrument this _____ day of _____ 20____

Cam Alfonso
Signature of Applicant

X Brad Chaffee
Signature of Owner

Cam Alfonso
Print name of Applicant

BRAD CHAFFEE
Print name of Owner

***FOR SIGNS COMPLETE PAGES 1 & 2 ONLY.
FOR SITE PLANS, BUILDING PLANS, PROJECTS, COMPLETE PAGES 1 - 4**

SEE ADDENDA ATTACHED FOR ASSISTANCE IN COMPLETION OF FORM Q

D) Architect/Engineer/Sign Company Information (if not the applicant)

a. Sign Company

Business Name: _____ Signs By Cam, Inc.
837 Upper Union Street
Contact Person: _____ Suite C-18
Address _____ Franklin, MA 02038
Telephone Number: _____

b. Architect/Engineer (when applicable)

Business Name: _____
Contact Person: _____
Address _____
Telephone Number: _____

E) Work Summary

Summary of work to be done: replace existing signs

F) Information & Materials to be Submitted with Application

a) FOR SIGN SUBMISSIONS ONLY:

**THE FOLLOWING MUST BE SUBMITTED ELECTRONICALLY TO
Mkinhart@franklinma.gov**

1. Drawing of Proposed Sign which must also include
type of sign (wall, pylon etc.) colors
size/dimensions materials
style of lettering lighting-illuminated, non-illuminated and style
2. Drawing and/or pictures indicating location of new sign.
3. Picture of existing location and signs (if previously existing location)

b) FOR BUILDINGS/DEVELOPMENTS OR PROJECT SUBMISSIONS:

THE FOLLOWING MUST BE SUBMITTED W/APPLICATION to Mkinhart@franklinma.gov

1. Site Plan including Landscape Plan showing plantings. Plantings must be from Best Development Practices Guide
2. Lighting Plan indicating lighting levels & specifications of proposed lights
3. Building drawings, indicating size and height of building(s); front, rear and side elevations (when there are no adjoining buildings) and floor plans
4. Drawings or pictures of existing conditions
5. If any signage on the building or site, provide information from above Signage Checklist

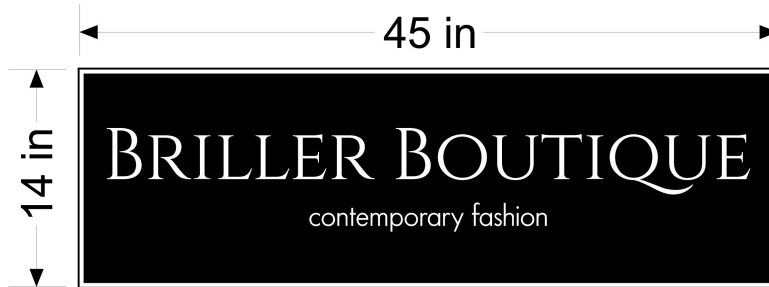
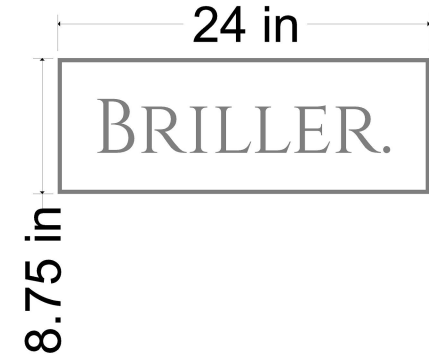

X2

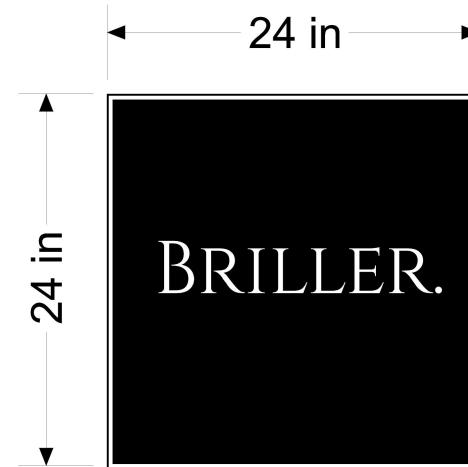

Signs By Cam Inc

Sign & Graphic Solutions • Uncompromising Integrity

Cam Afonso

837 Upper Union St., Suite C-18
Franklin, MA 02038

Phone: 508-364-2905

Fax/Office: 508-528-0766

E-Mail: cam@signsbycam.com

Website: www.signsbycam.com

APPROVED FOR PRODUCTION:

X

JOB INFORMATION

JOB TITLE:

CONTACT:

PHONE:

FAX:

JOB DESCRIPTION:

SQUARE FOOTAGE:=

SIGN MATERIAL SPECS

BANNER: COROPLAST: WOOD:

ACRYLIC: MAGNETIC: URETHANE:

PVC: ALUMINUM: NUEDGE:

SINGLE SIDED: DOUBLE SIDED:

OTHER: _____

© COPYRIGHT

ALL DRAWINGS ARE PROPERTY OF SIGNS BY CAM, Inc. ANY DUPLICATION OF ANY KIND IS PROHIBITED. PERSON(S) WILL BE PROSECUTED TO THE FULL EXTENT OF THE LAW.

COLOR SPECS:

BACKGROUND:

COPY:

OUTLINE:

SHADOW:

BORDER:

LOGO:

FORM Q

TOWN OF FRANKLIN
DESIGN REVIEW APPLICATION
FOR §185-31(2) OF THE ZONING BY-LAW

A) General Information

Name of Business or Project: Dean College

Property Address 119 Main St.

Assessors' Map # _____ Parcel # ~~279-045~~ - 279-125-000-000

Zoning District (select applicable zone): _____

Zoning History: Use Variance _____
Non-Conforming Use _____

B) Applicant Information:

Applicant Name: _____ Signs By Cam, Inc.
837 Upper Union Street

Address: _____ Suite C-18
Franklin, MA 02033

Telephone Number: 508-364-2905

Contact Person: Cam Afonso

C) Owner Information (Business Owner & Property Owner if different)

Business Owner: Dean College Property Owner: Dean College

Address: 99 Main St. 99 Main St.
Franklin, MA Franklin, MA

All of the information is submitted according to the best of my knowledge
Executed as a sealed instrument this _____ day of _____ 20____

Cam Afonso
Signature of Applicant

X Brian Kelly
Signature of Owner

Cam Afonso
Print name of Applicant

Brian Kelly, Rep
Print name of Owner

***FOR SIGNS COMPLETE PAGES 1 & 2 ONLY.
FOR SITE PLANS, BUILDING PLANS, PROJECTS, COMPLETE PAGES 1 - 4**

SEE ADDENDA ATTACHED FOR ASSISTANCE IN COMPLETION OF FORM Q

D) Architect/Engineer/Sign Company Information (if not the applicant)

a. Sign Company

Business Name: _____ Signs By Cam, Inc.
Contact Person: _____ 837 Upper Union Street
Address _____ Suite C-18
Franklin, MA 02038
Telephone Number: _____

b. Architect/Engineer (when applicable)

Business Name: _____
Contact Person: _____
Address _____
Telephone Number: _____

E) Work Summary

Summary of work to be done: replace 4 Monument Signs

F) Information & Materials to be Submitted with Application

a) FOR SIGN SUBMISSIONS ONLY:

THE FOLLOWING MUST BE SUBMITTED ELECTRONICALLY TO Mkinhart@franklinma.gov

1. Drawing of Proposed Sign which must also include
type of sign (wall, pylon etc.) colors
size/dimensions materials
style of lettering lighting-illuminated, non-illuminated and style
2. Drawing and/or pictures indicating location of new sign.
3. Picture of existing location and signs (if previously existing location)

b) FOR BUILDINGS/DEVELOPMENTS OR PROJECT SUBMISSIONS:

THE FOLLOWING MUST BE SUBMITTED W/APPLICATION to Mkinhart@franklinma.gov

1. Site Plan including Landscape Plan showing plantings. Plantings must be from Best Development Practices Guide
2. Lighting Plan indicating lighting levels & specifications of proposed lights
3. Building drawings, indicating size and height of building(s); front, rear and side elevations (when there are no adjoining buildings) and floor plans
4. Drawings or pictures of existing conditions
5. If any signage on the building or site, provide information from above Signage Checklist

RAISED PVC LETTERS

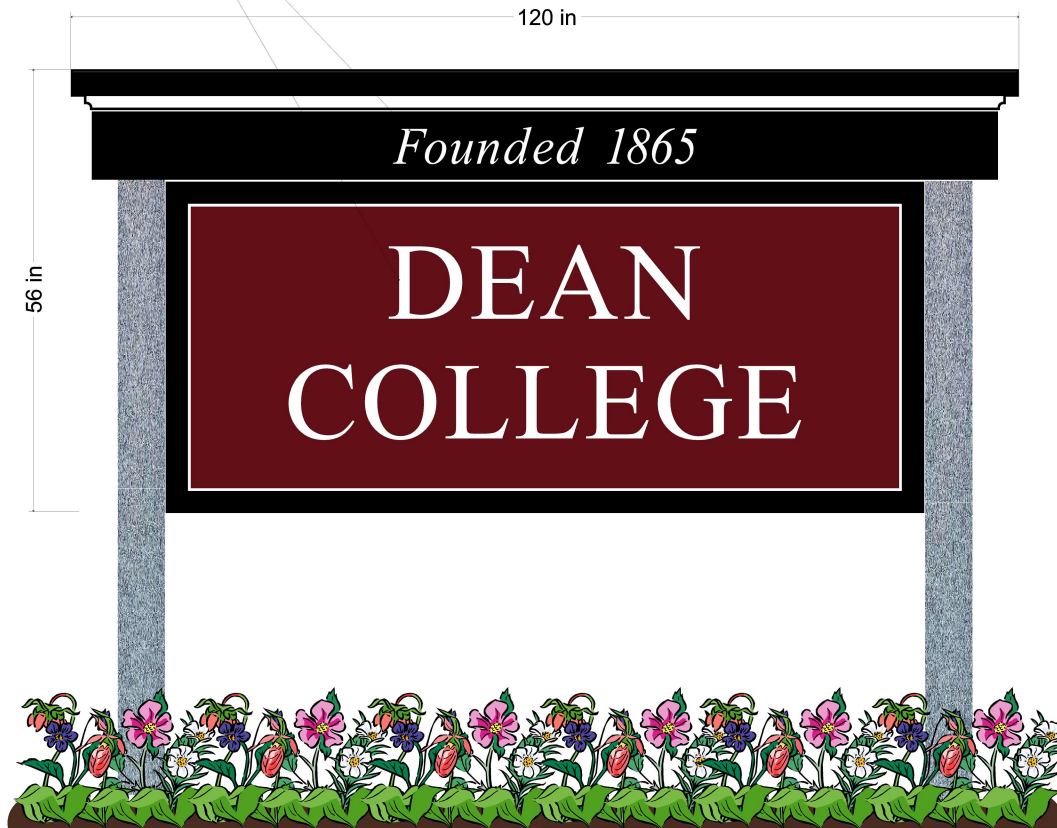

side view

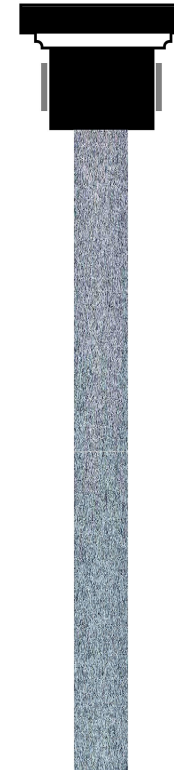

***our LED down lighting sample**



Signs By Cam Inc.

Sign & Graphic Solutions • Uncompromising Integrity

Cam Afonso

837 Upper Union St., Suite C-18
Franklin, MA 02038

Phone: 508-364-2905

Fax/Office: 508-528-0766

E-Mail: cam@signsbycam.com

Website: www.signsbycam.com

APPROVED FOR PRODUCTION:

X

JOB INFORMATION

JOB TITLE:

CONTACT:

PHONE:

FAX:

JOB DESCRIPTION:

SQUARE FOOTAGE: =

SIGN MATERIAL SPECS

BANNER: COROPLAST: WOOD:

ACRYLIC: MAGNETIC: URETHANE:

PVC: ALUMINUM: NUEDGE:

SINGLE SIDED: DOUBLE SIDED:

OTHER: _____

© COPYRIGHT

ALL DRAWINGS ARE PROPERTY OF SIGNS BY CAM, Inc. ANY DUPLICATION OF ANY KIND IS PROHIBITED. PERSON(S) WILL BE PROSECUTED TO THE FULL EXTENT OF THE LAW.

COLOR SPECS:

BACKGROUND:

COPY:

OUTLINE:

SHADOW:

BORDER:

LOGO:

FORM Q

TOWN OF FRANKLIN
DESIGN REVIEW APPLICATION
FOR §185-31(2) OF THE ZONING BY-LAW

A) General Information

Name of Business or Project: AVANTOR
Property Address 161 GROVE STREET
Assessors' Map # 306 Parcel # 042
Zoning District (select applicable zone): INDUSTRIAL
Zoning History: Use Variance N/A
Non-Conforming Use N/A

B) Applicant Information:

Applicant Name: HEATHER DUSKO (for: PHILADELPHIA SIGN Co.)
Address: 27 OLD MILLINGHOUSE ROAD
AUBURN, MA 01501
Telephone Number: 508-612-6954 hwoodhopkins@charter.net
Contact Person: HEATHER DUSKO

C) Owner Information (Business Owner & Property Owner if different)

Business Owner: AVANTOR Property Owner: 161 GROVE STREET LLC
Address: 161 GROVE STREET 13 WHEELING AVE
FRANKLIN, MA 02038 WOBURN, MA 01801

All of the information is submitted according to the best of my knowledge

Signature: Heather Hopkins Dusko Date Submitted: 1/17/2022
Print Name: HEATHER HOPKINS DUSKO

***FOR SIGNS COMPLETE PAGES 1 & 2 ONLY.**

FOR SITE PLANS, BUILDING PLANS, PROJECTS, COMPLETE PAGES 1 - 4

SEE ADDENDA ATTACHED FOR ASSISTANCE IN COMPLETION OF FORM Q

D) Architect/Engineer/Sign Company Information (if not the applicant)

a. Sign Company

Business Name: PHILADELPHIA SIGN COMPANY
Contact Person: JACQUELINE MATA
Address: 101 W. SPRING GARDENS ST. PALMYRA, NJ
Telephone Number: (856) 278-2300

b. Architect/Engineer (when applicable)

Business Name: _____
Contact Person: _____
Address: N/A
Telephone Number: _____

E) Work Summary

Summary of work to be done: REPLACE EXISTING WALL SIGN. NON ILLUMINATED CHANNEL LETTERS. 34.85 SQ FT (25.75" X 16' 2.75")
TO READ: AVANTOR.

F) Information & Materials to be Submitted with Application

(CODE ALLOWS GO UP IN INDUSTRIAL ZONE FOR WALL SIGN)

a) FOR SIGN SUBMISSIONS ONLY:

NINE (9) COPIES OF THE FOLLOWING MUST BE SUBMITTED WITH APPLICATION

1. Drawing of Proposed Sign which must also include
type of sign (wall, pylon etc.) colors
size/dimensions materials
style of lettering lighting-illuminated, non-illuminated and style
2. Drawing and/or pictures indicating location of new sign.
3. Picture of existing location and signs (if previously existing location)

b) FOR BUILDINGS/DEVELOPMENTS OR PROJECT SUBMISSIONS:

NINE (9) COPIES OF THE FOLLOWING MUST BE SUBMITTED W/APPLICATION

1. Site Plan including Landscape Plan showing plantings. Plantings must be from Best Development Practices Guide
2. Lighting Plan indicating lighting levels & specifications of proposed lights
3. Building drawings, indicating size and height of building(s); front, rear and side elevations (when there are no adjoining buildings) and floor plans
4. Drawings or pictures of existing conditions
5. If any signage on the building or site, provide information from above Signage Checklist

Note: Please bring a sample of the following to the meeting: materials samples (brick, siding, roofing etc.) as well as samples of paint colors.

Proposed



Signs Rendered Proportional to the Photo

 <p>PHILADELPHIASIGN BRINGING THE WORLD'S BRANDS TO LIFE</p>	TITLE	DWG BY	DATE	REVISION	BY
	Avantor	AC	11.12.21		
<p>ADDRESS AVT073 - Franklin MA 161 Grove Street Franklin, MA 02038</p>	DWG NUM	SHEET			
	A36882	2			
<p>THIS IS AN ORIGINAL UNPUBLISHED DRAWING CREATED BY P.S.C.O. IT IS SUBMITTED FOR YOUR PERSONAL USE IN CONNECTION WITH A PROJECT BEING PLANNED FOR YOU BY P.S.C.O. IT IS NOT TO BE SPREAD TO ANYONE ELSE. YOUR SPREAD TO ANYONE ELSE IS TO BE USED, COPIED, REPRODUCED, OR EXHIBITED IN ANY FASHION.</p>					

Sign Inventory

SITE: AVT073 - Franklin MA

SIGN PAGE: PROPOSED SIGN

E01 2 AVT-B-FL-18

WALL SIGN 34.8 ft
NON ILLUMINATED

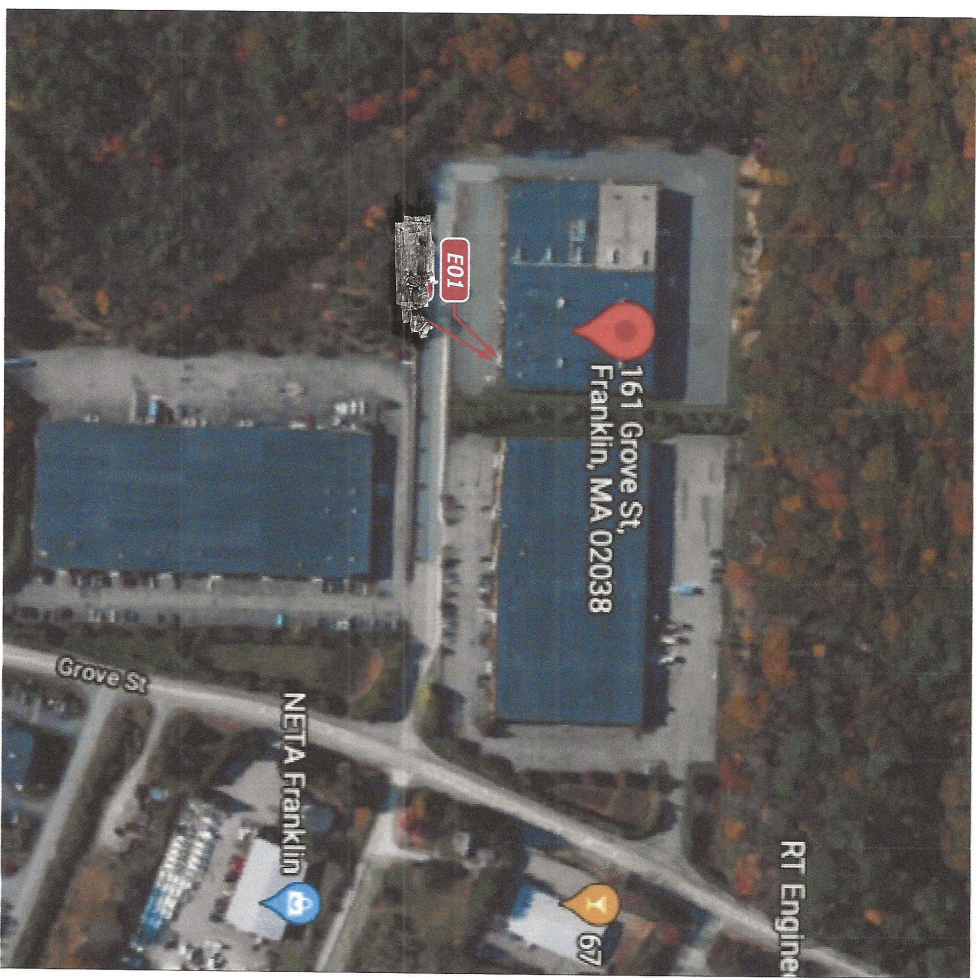

PHILADELPHIA SIGN
BRINGING THE WORLD'S BRANDS TO LIFE

TITLE	DWG BY	DATE	DATE	REVISION	BY
Avantor	AC	11.12.21			
ADDRESS		DWG NUM			
AVT073 - Franklin MA		A36882			
161 Grove Street		SHEET			
Franklin, MA 02038		1			

707 WEST SPRING GARDEN ST • PALMYRA, NJ • 08065 • P: 856-829-1460 • F: 856-829-9549 • WEB: <http://www.philadelphiasign.com>

THIS IS AN ORIGINAL UNPUBLISHED DRAWING CREATED BY P.S.C.O. IT IS SUBMITTED FOR YOUR PERSONAL USE IN CONJUNCTION WITH A PROJECT BEING PLANNED FOR YOU BY P.S.C.O. IT IS NOT TO BE SHOWN TO ANYONE OUTSIDE YOUR ORGANIZATION NOR IS IT TO BE USED, COPIED, REPRODUCED, OR EXHIBITED IN ANY FASHION.

Town of Franklin



Design Review Commission

**Tuesday, January 11, 2022
Meeting Minutes,**

Chair James Bartro called the above-captioned meeting to order this date at 7:00 PM, as a remote access virtual Zoom meeting. Members in attendance: Chair James Bartro, Vice Chair Sam Williams, Gerald Wood, Venkata Sompally. Members absent: Mark Fitzgerald, Associate Chris Baryluk. Also present: Maxine Kinhart, Administrative Staff.

As stated on the agenda, due to the continued concerns regarding the COVID-19 virus, this meeting will be conducted as a remote/virtual Design Review Commission meeting. In an effort to ensure citizen engagement and comply with open meeting law regulations, citizens will be able to dial into the meeting using the provided phone number, or citizens can participate by using the Zoom link provided on the agenda. This meeting was recorded.

1. Escape Into Fiction– 12 Main Street – Hanging business sign, 2 door transfer signs (front and back), 5 parking lot signs, and 1 sign on building facing parking lot above back door

April Rock, applicant, stated that they finished with the pop-up location at the end of the year. They are now moving into the former quilt shop location. Chair Bartro confirmed that the proposed blade sign will replace the blade sign that is already there. The front of the building facing Main Street will have an affixed sign, and there will be some door lettering. He stated that all that signage appears to be within the allowable limits. He stated that at the rear of the building they have a building sign. Ms. Rock stated that the sign will be a little smaller than what was there from the previous tenant. Chair Bartro stated that looks as though it is in accordance with the bylaw. He stated that there is a directional sign on the wall next to the parking sign. Ms. Rock stated yes; she said that she is replacing the signage that is already there. She stated that the blade sign is not illuminated. Chair Bartro stated that all signs were in the same locations as they were with the previous tenant. Ms. Rock stated that there are four parking spots.

Motion: To **Approve** the sign package as submitted. Motioned by S. Williams. Seconded by V. Sompally. Roll Call Vote: Williams-YES; Wood-YES; Sompally-YES; Bartro-YES. Voted 4-0-0.

2. T&T Nails & Spa– 315 East Central Street- Attach a channel letter sign to the building

Mr. Ricky Zeng, applicant, addressed the Commission. Chair Bartro confirmed that the applicant was proposing the building sign and the sign in the pylon. Mr. Zeng stated yes. Chair Bartro confirmed that it was an LED raceway mounted sign internally illuminated.

Motion: To **Approve** the sign package as submitted. Motioned by S. Williams. Seconded by G. Wood. Roll Call Vote: Williams-YES; Wood-YES; Sompally-YES; Bartro-YES. Voted 4-0-0.

Approval of Minutes: December 7, 2021

Chair Bartro reviewed that at the December 7th meeting the Commission discussed the Sign Tech Attachment 10 Addendum. He stated that the feedback from that discussion was positive. He stated that there is an additional set of revisions to do regarding the sign technology and they should plan to discuss this item again during an upcoming meeting.

Motion: To **Approve** the December 7, 2021 Meeting Minutes as presented. Motioned by S. Williams. Seconded by V. Sompally. Roll Call Vote: Williams-YES; Wood-ABSTAIN; Sompally-YES; Bartro-YES. Voted 3-0-1.

General Matters - Old Business

Chair Bartro stated that he followed up with the building commissioner about the Liquor World sign. He and the building commissioner have reached out to the building owner and property manager. They have expressed the belief that the sign was installed without a permit and that it was moved from a position lower in the pylon to a bigger space higher in the pylon; he and the building commissioner would like to see it permitted. Chair Bartro stated that the way the sign was constructed is not in line with the standard; it is an unshielded sign and throws off much light. He is waiting for a response from the property manager.

Chair Bartro confirmed that a formal letter of resignation has not been received from Mark Fitzgerald. He stated that he would follow up with Mr. Fitzgerald. He stated that he believes Mr. Fitzgerald has moved out of town. He stated that when that letter is received, there will be one full member opening and one associate member opening for the Design Review Commission. He asked Ms. Kihnart for the contact information for the two applicants so he can reach out to them.

Mr. Williams reiterated his signage bylaw recommendation provided at the last meeting regarding creating uniformity of size of signs at 1 sq. ft. per foot of frontage. Chair Bartro stated that once this item is on an upcoming agenda, Mr. Williams should write this up and submit it for review with the Commission.

General Matters - New Business

Mr. Williams stated that on Rt. 140 where the Botera dispensary is located, another business, Siena Analytics, has gone in. They have a sign with a white background and dark color letters that is illuminated. He does not believe that sign came before the Commission, and if it did, it was approved in error as it is not in conformance with the bylaw requiring a dark background. Chair Bartro stated that he would review the meeting minutes; if no record of it is found, he will reach out to the building commissioner.

Motion to Adjourn by S. Williams. Seconded by G. Wood. Roll Call Vote: Williams-YES; Wood-YES; Sompally-YES; Bartro-YES. Voted 4-0-0.

Meeting adjourned at 7:19 PM.

Respectfully submitted,

Judith Lizardi
Recording Secretary